

THIS COPY IS PROVIDED ON A RESTRICTED BASIS AND IS NOT TO BE USED IN ANY WAY DETRIMENTAL TO THE INTERESTS OF PANDUIT CORP.

NOTES:

1. MILLIMETER ARE IN [    ].
2. CAUTION HEADER IS TAG COLOR ON BLACK BACKGROUND, REMAINDER OF TAG IS BLACK TEXT ON COLORED BACKGROUND.

PART NUMBER	COLOR
GPST-FO	BLACK ON YELLOW
GPST-FO-OR	BLACK ON ORANGE
PST-FO	BLACK ON YELLOW

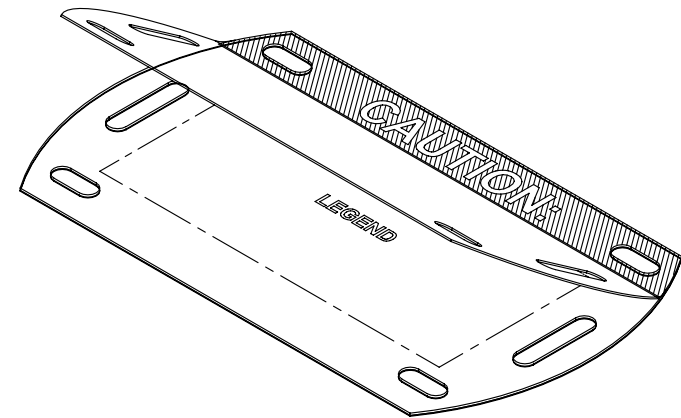
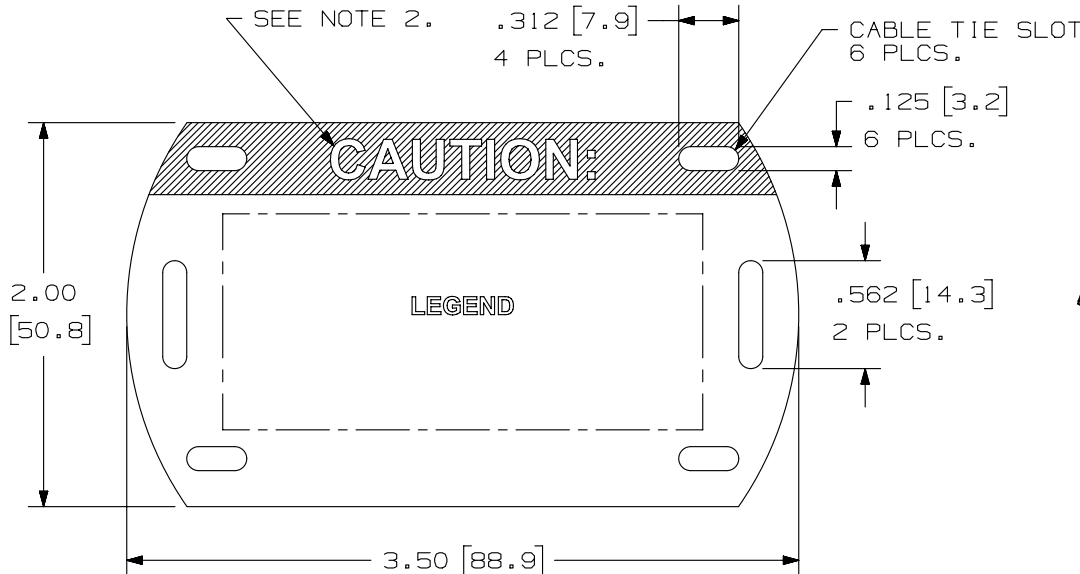

REV	DATE	BY	CHK	APR	DESCRIPTION	ECN
3	11/20/14	RVU	MJPF	MSAD	ADD PN, PST-FO TO TABLE. UPDATE MATERIALS.	GAECN02375
2	7/29/14	RVU	MJPF	MSAD	NOTCHES NEED TO BE RELOCATED. CHANGE TEXT TO LEGEND.	GAECN02198
1	12/20/13	JHAC	MJPF	KLN	ADDED PART NUMBER TABLE AND NOTE 2.	GAECN01513
0	10/15/09	RVU			DRAWING RELEASE.	5882

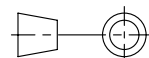
TITLE		<b>FIBER OPTIC CABLE TAG</b>	
		CUSTOMER DRAWING	
ITEM REVISION NAME		100281LC/03	
DATASET FILE NAME		100281LC_DC_C10801/03D	
UNLESS OTHERWISE SPECIFIED, DIMENSIONAL TOLERANCES ARE: IN [mm]		 <b>PST-FO</b>	
.x ± .12 [ 3.05]    .xxx ± .025 [ .635 ] .xx ± .062 [ 1.57 ]    ANGLES ±			
		DRAWING NUMBER:	
		C10801	
DRAWN BY	DATE	CHK	SCALE
RVU	10/15/09	MSAD	NTS
SHT 1 OF 1			A