

THIS DRAWING IS UNPUBLISHED. RELEASED FOR PUBLICATION
 © COPYRIGHT - By - ALL RIGHTS RESERVED.

LOC		DIST		REVISIONS			
P	LTR	DESCRIPTION		DATE	DWN	APVD	
AF	50	J2	ECR-15-005665	10AUG2015	BDA	PKS	

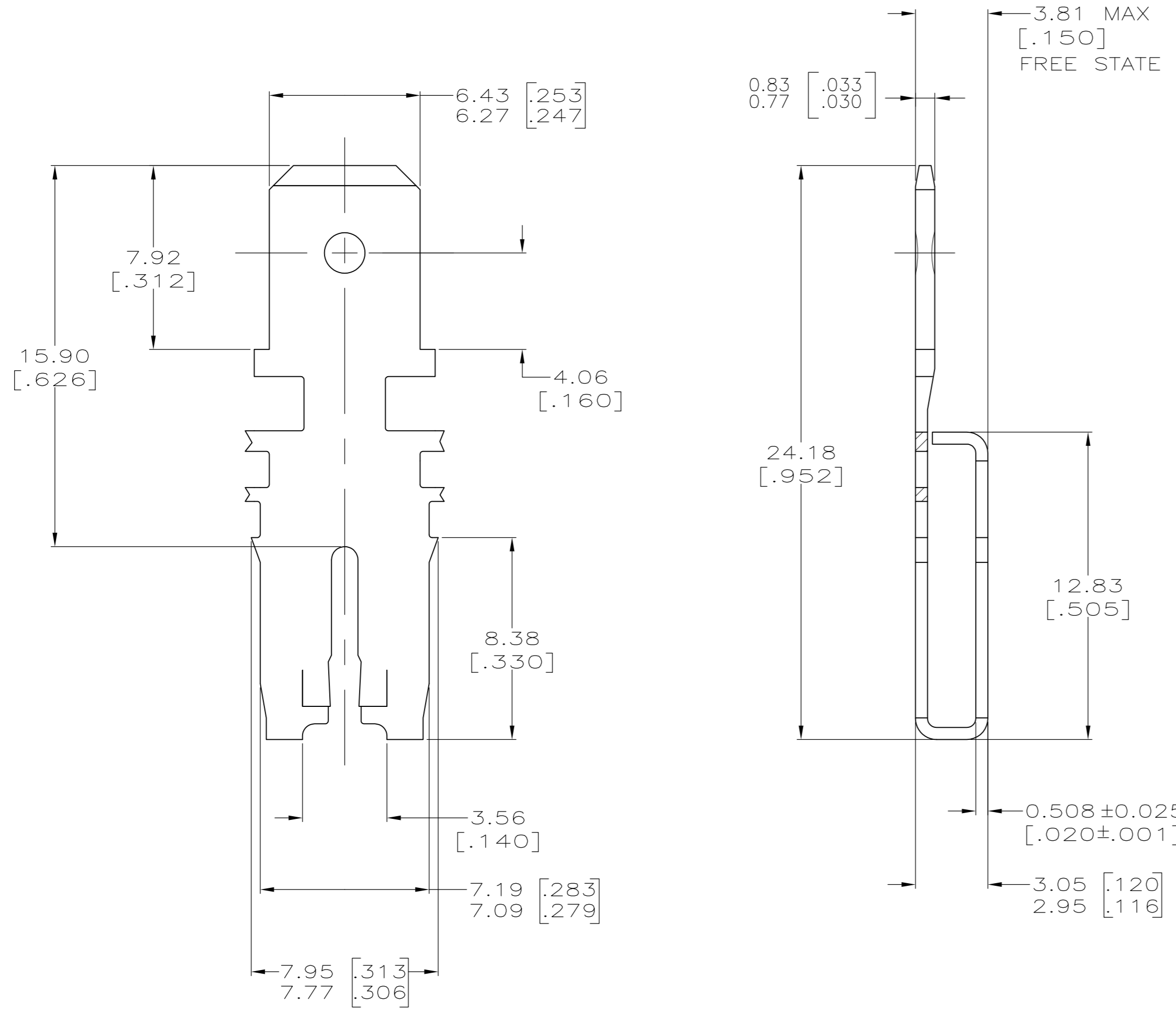

- CONTINUOUS STRIP ON REELS WITH TERMINALS LOCATED ON 8.38±0.08 [.330±.003] CENTERS.
- △ SLOT ACCEPTS 1.45-1.29mm DIA [#15-#16] AWG COPPER MAGNET WIRE.
SLOT ACCEPTS 1.37-1.54mm DIA [#15.5-#14.5] AWG ALUMINUM MAGNET WIRE.
ALUMINUM WIRE RANGE APPLIES FOR POST-TIN PLATED VERSIONS ONLY.TWO WIRES OF THE SAME SIZE MAX PER SLOT.
- AFTER INSERTION INTO PLASTIC HOLDER, TAB PORTION MUST BE BENT OVER 45° TO 90° OR POTTED-IN TO PREVENT PULL-OUT WHEN MATING RECEPTACLE IS DISCONNECTED.
- △ VARNISH RESIST OVER TIN PLATE.
- △ PRELIMINARY - NOT FOR PRODUCTION.

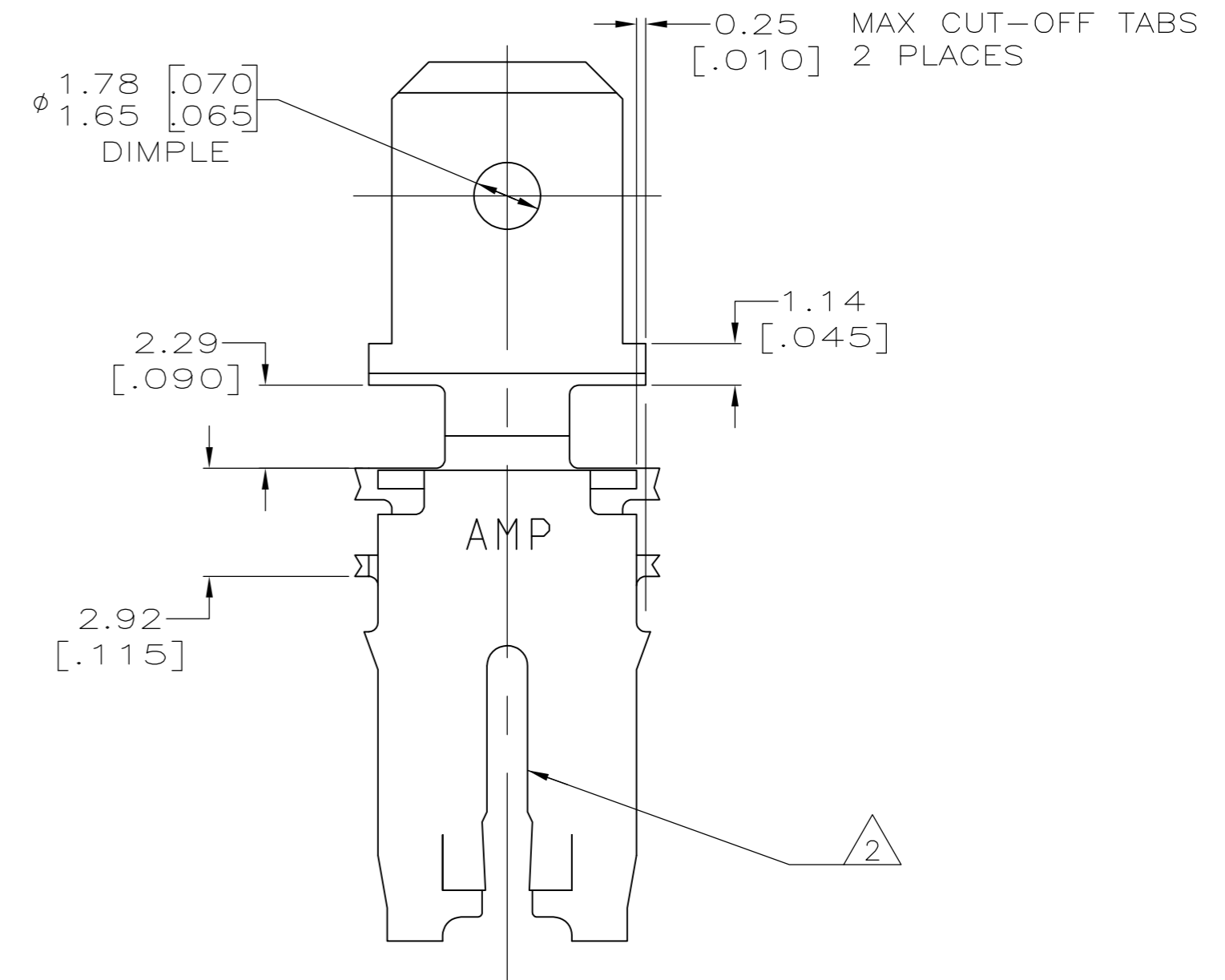

H04 PRE-MILLED PHOS BRONZE	△ 63064-2
4M PRE-MILLED BRASS	63064-1
MATERIAL	PART NUMBER

THIS DRAWING IS A CONTROLLED DOCUMENT.		DWN MICHAEL S. FEHER 07MAY1999	TE TE Connectivity	
DIMENSIONS: mm [INCHES]		CHK JEFF R. RUTH 07JUN1999		
TOLERANCES UNLESS OTHERWISE SPECIFIED:		APVD KURT A. RANDOLPH 07JUN1999	NAME TAB, 6.35 [.250] FASTON, 500 SERIES MAG-MATE	
0 PLC ± -		PRODUCT SPEC 108-2053	SIZE A2	
1 PLC ± -		APPLICATION SPEC 114-2066	CAGE CODE 00779	DRAWING NO C=63064
2 PLC ± 0.25 [.010]		WEIGHT -	SCALE 6:1	SHEET 1 of 1
3 PLC ± -		MATERIAL SEE TABLE	REV J2	RESTRICTED TO -
4 PLC ± -		FINISH △ 4		
4 ANGLES ± -		CUSTOMER DRAWING		