

## Description

The ICS9DB403 is compatible with the Intel DB400v2 Differential Buffer Specification. This buffer provides 4 PCI-Express Gen2 clocks. The ICS9DB403 is driven by a differential output pair from a CK410B+, CK505 or CK509B main clock generator.

## Output Features

- 4 - 0.7V current-mode differential output pairs
- Supports zero delay buffer mode and fanout mode
- Bandwidth programming available
- 50-100 MHz operation in PLL mode
- 50-400 MHz operation in Bypass mode

## Features/Benefits

- Spread spectrum modulation tolerant, 0 to -0.5% down spread and +/- 0.25% center spread.
- Supports undriven differential outputs in PD# and SRC\_STOP# modes for power management.

## Key Specifications

- Outputs cycle-cycle jitter < 50ps
- Outputs skew: 50ps
- Phase jitter: PCIe Gen1 < 86ps peak to peak
- Phase jitter: PCIe Gen2 < 3.0/3.1ps rms
- 28-pin SSOP/TSSOP package
- Available in RoHS compliant packaging
- Supports Commercial (0 to +70°C) and Industrial (-40 to +85°C) temperature ranges

## Functional Block Diagram

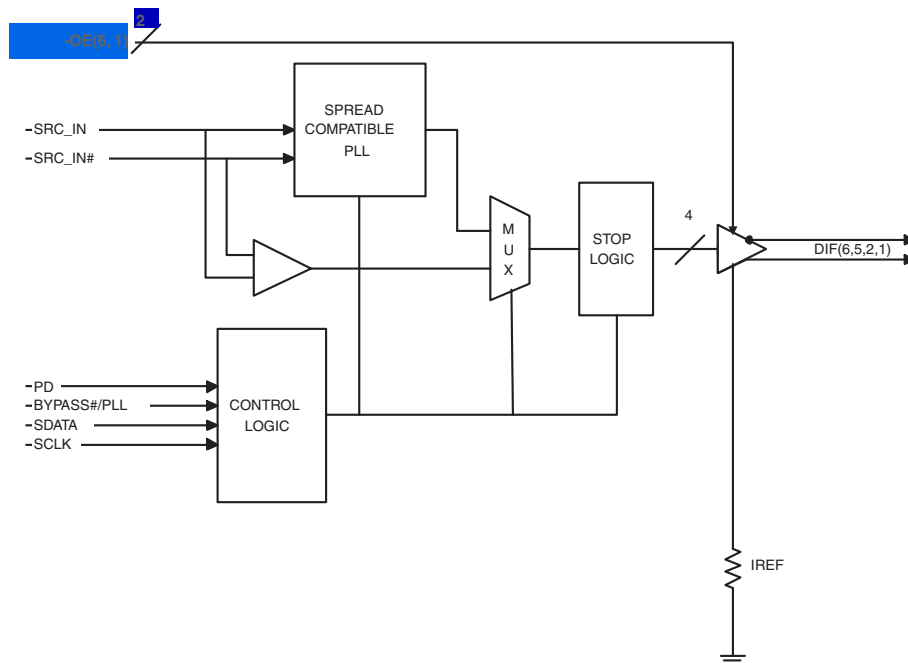

Note: Polarities shown for OE\_INV = 0.

### Pin Configuration

VDDR	1	<b>ICS9DB403D</b> <b>(same as ICS9DB104)</b>	28	VDDA
SRC_IN	2		27	GNDA
SRC_IN#	3		26	IREF
GND	4		25	OE_INV
VDD	5		24	VDD
DIF_1	6		23	DIF_6
DIF_1#	7		22	DIF_6#
OE_1	8		21	OE_6
DIF_2	9		20	DIF_5
DIF_2#	10		19	DIF_5#
VDD	11		18	VDD
BYPASS#/PLL	12		17	HIGH_BW#
SCLK	13		16	DIF_STOP#
SDATA	14		15	PD#

**OE\_INV = 0**

VDDR	1	<b>ICS9DB403D</b> <b>(same as ICS9DB401)</b>	28	VDDA
SRC_IN	2		27	GNDA
SRC_IN#	3		26	IREF
GND	4		25	<b>OE_INV</b>
VDD	5		24	VDD
DIF_1	6		23	DIF_6
DIF_1#	7		22	DIF_6#
<b>OE1#</b>	8		21	<b>OE6#</b>
DIF_2	9		20	DIF_5
DIF_2#	10		19	DIF_5#
VDD	11		18	VDD
BYPASS#/PLL	12		17	HIGH_BW#
SCLK	13		16	<b>DIF_STOP</b>
SDATA	14		15	<b>PD</b>

**OE\_INV = 1**

### 28-pin SSOP & TSSOP

#### Polarity Inversion Pin List Table

Pins	OE_INV	
	0	1
8	OE_1	OE1#
15	PD#	PD
16	DIF_STOP#	DIF_STOP
21	OE_6	OE6#

#### Power Groups

Pin Number		Description
VDD	GND	
1	4	SRC_IN/SRC_IN#
5, 11, 18, 24	4	DIF(1,2,5,6)
N/A	27	IREF
28	27	Analog VDD & GND for PLL core

**Pin Description When OE\_INV = 0**

PIN #	PIN NAME	PIN TYPE	DESCRIPTION
1	VDDR	PWR	3.3V power for differential input clock (receiver). This VDD should be treated as an analog power rail and filtered appropriately.
2	SRC_IN	IN	0.7 V Differential SRC TRUE input
3	SRC_IN#	IN	0.7 V Differential SRC COMPLEMENTARY input
4	GND	PWR	Ground pin.
5	VDD	PWR	Power supply, nominal 3.3V
6	DIF_1	OUT	0.7V differential true clock output
7	DIF_1#	OUT	0.7V differential Complementary clock output
8	OE_1	IN	Active high input for enabling output 1. 0 =disable outputs, 1= enable outputs
9	DIF_2	OUT	0.7V differential true clock output
10	DIF_2#	OUT	0.7V differential Complementary clock output
11	VDD	PWR	Power supply, nominal 3.3V
12	BYPASS#/PLL	IN	Input to select Bypass(fan-out) or PLL (ZDB) mode 0 = Bypass mode, 1= PLL mode
13	SCLK	IN	Clock pin of SMBus circuitry, 5V tolerant.
14	SDATA	I/O	Data pin for SMBus circuitry, 5V tolerant.
15	PD#	IN	Asynchronous active low input pin used to power down the device. The internal clocks are disabled and the VCO and the crystal osc. (if any) are stopped.
16	DIF_STOP#	IN	Active low input to stop differential output clocks.
17	HIGH_BW#	IN	3.3V input for selecting PLL Band Width 0 = High, 1= Low
18	VDD	PWR	Power supply, nominal 3.3V
19	DIF_5#	OUT	0.7V differential Complementary clock output
20	DIF_5	OUT	0.7V differential true clock output
21	OE_6	IN	Active high input for enabling output 6. 0 =disable outputs, 1= enable outputs
22	DIF_6#	OUT	0.7V differential Complementary clock output
23	DIF_6	OUT	0.7V differential true clock output
24	VDD	PWR	Power supply, nominal 3.3V
25	OE_INV	IN	This latched input selects the polarity of the OE pins. 0 = OE pins active high, 1 = OE pins active low (OE#)
26	IREF	OUT	This pin establishes the reference for the differential current-mode output pairs. It requires a fixed precision resistor to ground. 475ohm is the standard value for 100ohm differential impedance. Other impedances require different values. See data sheet.
27	GND_A	PWR	Ground pin for the PLL core.
28	VDDA	PWR	3.3V power for the PLL core.

**ICS9DB403D**  
**Four Output Differential Buffer for PCIe for Gen 1 and Gen 2**

**Pin Description When OE\_INV = 1**

PIN #	PIN NAME	PIN TYPE	DESCRIPTION
1	VDDR	PWR	3.3V power for differential input clock (receiver). This VDD should be treated as an analog power rail and filtered appropriately.
2	SRC_IN	IN	0.7 V Differential SRC TRUE input
3	SRC_IN#	IN	0.7 V Differential SRC COMPLEMENTARY input
4	GND	PWR	Ground pin.
5	VDD	PWR	Power supply, nominal 3.3V
6	DIF_1	OUT	0.7V differential true clock output
7	DIF_1#	OUT	0.7V differential Complementary clock output
8	OE1#	IN	Active low input for enabling DIF pair 1. 1 =disable outputs, 0 = enable outputs
9	DIF_2	OUT	0.7V differential true clock output
10	DIF_2#	OUT	0.7V differential Complementary clock output
11	VDD	PWR	Power supply, nominal 3.3V
12	BYPASS#/PLL	IN	Input to select Bypass(fan-out) or PLL (ZDB) mode 0 = Bypass mode, 1= PLL mode
13	SCLK	IN	Clock pin of SMBus circuitry, 5V tolerant.
14	SDATA	I/O	Data pin for SMBus circuitry, 5V tolerant.
15	PD	IN	Asynchronous active high input pin used to power down the device. The internal clocks are disabled and the VCO is stopped.
16	DIF_STOP	IN	Active High input to stop differential output clocks.
17	HIGH_BW#	IN	3.3V input for selecting PLL Band Width 0 = High, 1= Low
18	VDD	PWR	Power supply, nominal 3.3V
19	DIF_5#	OUT	0.7V differential Complementary clock output
20	DIF_5	OUT	0.7V differential true clock output
21	OE6#	IN	Active low input for enabling DIF pair 6. 1 =disable outputs, 0 = enable outputs
22	DIF_6#	OUT	0.7V differential Complementary clock output
23	DIF_6	OUT	0.7V differential true clock output
24	VDD	PWR	Power supply, nominal 3.3V
25	OE_INV	IN	This latched input selects the polarity of the OE pins. 0 = OE pins active high, 1 = OE pins active low (OE#)
26	IREF	OUT	This pin establishes the reference for the differential current-mode output pairs. It requires a fixed precision resistor to ground. 475ohm is the standard value for 100ohm differential impedance. Other impedances require different values. See data sheet.
27	GND_A	PWR	Ground pin for the PLL core.
28	VDD_A	PWR	3.3V power for the PLL core.

## Absolute Max

Symbol	Parameter	Min	Max	Units
VDDA/R	3.3V Core Supply Voltage		4.6	V
VDD	3.3V Logic Supply Voltage		4.6	V
V <sub>IL</sub>	Input Low Voltage	GND-0.5		V
V <sub>IH</sub>	Input High Voltage		V <sub>DD</sub> +0.5V	V
T <sub>s</sub>	Storage Temperature	-65	150	°C
T <sub>ambient</sub>	Commerical Operating Range	0	70	°C
	Industrial Operating Range	-40	85	°C
T <sub>case</sub>	Case Temperature		115	°C
ESD prot	Input ESD protection human body model	2000		V

## Electrical Characteristics - Clock Input Parameters

T<sub>A</sub> = T<sub>ambient</sub> for the desired operating range, Supply Voltage V<sub>DD</sub> = 3.3 V +/-5%

PARAMETER	SYMBOL	CONDITIONS	MIN	TYP	MAX	UNITS	NOTES
Input High Voltage - DIF_IN	V <sub>IHDIF</sub>	Differential inputs (single-ended measurement)	600	800	1150	mV	1
Input Low Voltage - DIF_IN	V <sub>ILDIF</sub>	Differential inputs (single-ended measurement)	V <sub>SS</sub> - 300	0	300	mV	1
Input Common Mode Voltage - DIF_IN	V <sub>COM</sub>	Common Mode Input Voltage	300		1000	mV	1
Input Amplitude - DIF_IN	V <sub>SWING</sub>	Peak to Peak value (single-ended measurement)	300		1450	mV	1
Input Slew Rate - DIF_IN	dv/dt	Measured differentially	0.4		8	V/ns	1,2
Input Leakage Current	I <sub>IN</sub>	V <sub>IN</sub> = V <sub>DD</sub> , V <sub>IN</sub> = GND	-5		5	uA	1
Input Duty Cycle	d <sub>tin</sub>	Measurement from differential waveform	45		55	%	1
Input Jitter - Cycle to Cycle	J <sub>DIFin</sub>	Differential Measurement	0		125	ps	1

<sup>1</sup> Guaranteed by design and characterization, not 100% tested in production.

<sup>2</sup> Slew rate measured through V<sub>swing</sub> min centered around differential zero

**ICS9DB403D**  
**Four Output Differential Buffer for PCIe for Gen 1 and Gen 2**

**Electrical Characteristics - Input/Supply/Common Output Parameters**

T<sub>A</sub> = Tambient for the desired operating range, Supply Voltage V<sub>DD</sub> = 3.3 V +/-5%

PARAMETER	SYMBOL	CONDITIONS	MIN	TYP	MAX	UNITS	NOTES
Input High Voltage	V <sub>IHSE</sub>	Single Ended Inputs, 3.3 V +/-5%	2		V <sub>DD</sub> + 0.3	V	1
Input Low Voltage	V <sub>ILSE</sub>		GND - 0.3		0.8	V	1
Input High Current	I <sub>IHSE</sub>	V <sub>IN</sub> = V <sub>DD</sub>	-5		5	uA	1
Input Low Current	I <sub>IL1</sub>	V <sub>IN</sub> = 0 V; Inputs with no pull-up resistors	-5			uA	1
	I <sub>IL2</sub>	V <sub>IN</sub> = 0 V; Inputs with pull-up resistors	-200			uA	1
9DB803 Supply Current	I <sub>DD3.3OPC</sub>	Full Active, C <sub>L</sub> = Full load; Commerical Temp Range		175	200	mA	1
	I <sub>DD3.3OPI</sub>	Full Active, C <sub>L</sub> = Full load; Industrial Temp Range		190	225	mA	1
9DB803 Powerdown Current	I <sub>DD3.3PDC</sub>	all diff pairs driven, C-Temp		50	60	mA	1
		all differential pairs tri-stated, C-Temp		4	6	mA	1
	I <sub>DD3.3PDI</sub>	all diff pairs driven, I-temp		55	65	mA	1
		all differential pairs tri-stated, I-temp		6	8	mA	1
9DB403 Supply Current	I <sub>DD3.3OPC</sub>	Full Active, C <sub>L</sub> = Full load; Commerical Temp Range		105	125	mA	1
	I <sub>DD3.3OPI</sub>	Full Active, C <sub>L</sub> = Full load; Industrial Temp Range		115	150	mA	1
9DB403 Powerdown Current	I <sub>DD3.3PDC</sub>	all diff pairs driven, C-Temp		25	30	mA	1
		all differential pairs tri-stated, C-Temp		2	3	mA	1
	I <sub>DD3.3PDI</sub>	all diff pairs driven, I-Temp		30	35	mA	1
		all differential pairs tri-stated, I-Temp		3	4	mA	1
Input Frequency	F <sub>IPLL</sub>	PCle Mode (Bypass#/PLL= 1)	50	100.00	110	MHz	1
	F <sub>I BYPASS</sub>	Bypass Mode ((Bypass#/PLL= 0)	33		400	MHz	1
Pin Inductance	L <sub>pin</sub>				7	nH	1
Capacitance	C <sub>IN</sub>	Logic Inputs, except SRC_IN	1.5		5	pF	1
	C <sub>INSRC_IN</sub>	SRC_IN differential clock inputs	1.5		2.7	pF	1,4
	C <sub>OUT</sub>	Output pin capacitance			6	pF	1
PLL Bandwidth	BW	-3dB point in High BW Mode	2	3	4	MHz	1
		-3dB point in Low BW Mode	0.7	1	1.4	MHz	1
PLL Jitter Peaking	t <sub>JPEAK</sub>	Peak Pass band Gain		1.5	2	dB	1
Clk Stabilization	T <sub>STAB</sub>	From V <sub>DD</sub> Power-Up and after input clock stabilization or de-assertion of PD# to 1st clock			1	ms	1,2
Input SS Modulation Frequency	f <sub>MODIN</sub>	Allowable Frequency (Triangular Modulation)	30		33	kHz	1
OE# Latency	t <sub>LATOE#</sub>	DIF start after OE# assertion DIF stop after OE# deassertion	1		3	cycles	1,3
Tdrive_SRC_STOP#	t <sub>DRVSTP</sub>	DIF output enable after SRC_Stop# de-assertion			10	ns	1,3
Tdrive_PD#	t <sub>DRVPD</sub>	DIF output enable after PD# de-assertion			300	us	1,3
Tfall	t <sub>F</sub>	Fall time of PD# and SRC_STOP#			5	ns	1
Trise	t <sub>R</sub>	Rise time of PD# and SRC_STOP#			5	ns	2
SMBus Voltage	V <sub>MAX</sub>	Maximum input voltage			5.5	V	1
Low-level Output Voltage	V <sub>OL</sub>	@ I <sub>PULLUP</sub>			0.4	V	1
Current sinking at V <sub>OL</sub>	I <sub>PULLUP</sub>		4			mA	1
SCLK/SDATA Clock/Data Rise Time	t <sub>RSMB</sub>	(Max VIL - 0.15) to (Min VIH + 0.15)			1000	ns	1
SCLK/SDATA Clock/Data Fall Time	t <sub>FSMB</sub>	(Min VIH + 0.15) to (Max VIL - 0.15)			300	ns	1
SMBus Operating Frequency	f <sub>MAXSMB</sub>	Maximum SMBus operating frequency			100	kHz	1,5

<sup>1</sup>Guaranteed by design and characterization, not 100% tested in production.

<sup>2</sup>See timing diagrams for timing requirements.

<sup>3</sup>Time from deassertion until outputs are >200 mV

<sup>4</sup>SRC\_IN input

<sup>5</sup>The differential input clock must be running for the SMBus to be active

**Electrical Characteristics - DIF 0.7V Current Mode Differential Pair**

$T_A = T_{\text{ambient}}$ ;  $V_{DD} = 3.3 \text{ V} \pm 5\%$ ;  $C_L = 2\text{pF}$ ,  $R_S = 33\Omega$ ,  $R_P = 49.9\Omega$ ,  $R_{REF} = 475\Omega$

PARAMETER	SYMBOL	CONDITIONS	MIN	TYP	MAX	UNITS	NOTES
Current Source Output Impedance	$Z_{o1}$		3000			$\Omega$	1
Voltage High	VHigh	Statistical measurement on single ended signal using oscilloscope math function.	660		850	mV	1,2
Voltage Low	VLow		-150		150		1,2
Max Voltage	Vovs	Measurement on single ended signal using absolute value.			1150	mV	1
Min Voltage	Vuds		-300				1
Crossing Voltage (abs)	Vcross(abs)		250		550	mV	1
Crossing Voltage (var)	d-Vcross	Variation of crossing over all edges			140	mV	1
Rise Time	$t_r$	$V_{OL} = 0.175\text{V}$ , $V_{OH} = 0.525\text{V}$	175		700	ps	1
Fall Time	$t_f$	$V_{OH} = 0.525\text{V}$ $V_{OL} = 0.175\text{V}$	175		700	ps	1
Rise Time Variation	d- $t_r$				125	ps	1
Fall Time Variation	d- $t_f$				125	ps	1
Duty Cycle	$d_{t3}$	Measurement from differential waveform	45		55	%	1
Skew, Input to Output	$t_{pdBYP}$	Bypass Mode, $V_T = 50\%$	2500		5000	ps	1
	$t_{pdPLL}$	PLL Mode $V_T = 50\%$	-250		250	ps	1
Skew, Output to Output	$t_{sk3}$	$V_T = 50\%$			50	ps	1
		PLL mode			50	ps	1,3
Jitter, Cycle to cycle	$t_{j\text{cyc-cyc}}$	Additive Jitter in Bypass Mode			50	ps	1,3
Jitter, Phase	$t_{j\text{phaseBYP}}$	PCIe Gen1 phase jitter (Additive in Bypass Mode)		7	10	ps (pk2pk)	1,4,5
		PCIe Gen 2 Low Band phase jitter (Additive in Bypass Mode)		0	0.1	ps (rms)	1,4,5
		PCIe Gen 2 High Band phase jitter (Additive in Bypass Mode)		0.3	0.5	ps (rms)	1,4,5
	$t_{j\text{phasePLL}}$	PCIe Gen 1 phase jitter		40	86	ps (pk2pk)	1,4,5
		PCIe Gen 2 Low Band phase jitter		1.5	3	ps (rms)	1,4,5
		PCIe Gen 2 High Band phase jitter		2.7/ 2.2	3.1	ps (rms)	1,4,5,6

<sup>1</sup>Guaranteed by design and characterization, not 100% tested in production.

<sup>2</sup> $I_{REF} = V_{DD}/(3 \times R_R)$ . For  $R_R = 475\Omega$  (1%),  $I_{REF} = 2.32\text{mA}$ .  $I_{OH} = 6 \times I_{REF}$  and  $V_{OH} = 0.7\text{V}$  @  $Z_O = 50\Omega$ .

<sup>3</sup> Measured from differential waveform

<sup>4</sup> See <http://www.pcisig.com> for complete specs

<sup>5</sup> Device driven by 932S421C or equivalent.

<sup>6</sup> First number is High Bandwidth Mode, second number is Low Bandwidth Mode

### Clock Periods Differential Outputs with Spread Spectrum Enabled

Measurement Window		1 Clock	1us	0.1s	0.1s	0.1s	1us	1 Clock	Units	Notes
Symbol		Lg-	-SSC	-ppm error	0ppm	+ ppm error	+SSC	Lg+		
Definition		Absolute Period	Short-term Average	Long-Term Average	Period	Long-Term Average	Short-term Average	Period		
		Minimum Absolute Period	Minimum Absolute Period	Minimum Absolute Period	Nominal	Maximum	Maximum	Maximum		
Signal Name	DIF 100	9.87400	9.99900	9.99900	10.00000	10.00100	10.05130	10.17630	ns	1,2,3
	DIF 133	7.41425	7.49925	7.49925	7.50000	7.50075	7.53845	7.62345	ns	1,2,4
	DIF 166	5.91440	5.99940	5.99940	6.00000	6.00060	6.03076	6.11576	ns	1,2,4
	DIF 200	4.91450	4.99950	4.99950	5.00000	5.00050	5.02563	5.11063	ns	1,2,4
	DIF 266	3.66463	3.74963	3.74963	3.75000	3.75038	3.76922	3.85422	ns	1,2,4
	DIF 333	2.91470	2.99970	2.99970	3.00000	3.00030	3.01538	3.10038	ns	1,2,4
	DIF 400	2.41475	2.49975	2.49975	2.50000	2.50025	2.51282	2.59782	ns	1,2,4

### Clock Periods Differential Outputs with Spread Spectrum Disabled

Measurement Window		1 Clock	1us	0.1s	0.1s	0.1s	1us	1 Clock	Units	Notes
Symbol		Lg-	-SSC	-ppm error	0ppm	+ ppm error	+SSC	Lg+		
Definition		Absolute Period	Short-term Average	Long-Term Average	Period	Long-Term Average	Short-term Average	Period		
		Minimum Absolute Period	Minimum Absolute Period	Minimum Absolute Period	Nominal	Maximum	Maximum	Maximum		
Signal Name	DIF 100	9.87400		9.99900	10.00000	10.00100		10.17630	ns	1,2,3
	DIF 133	7.41425		7.49925	7.50000	7.50075		7.62345	ns	1,2,4
	DIF 166	5.91440		5.99940	6.00000	6.00060		6.11576	ns	1,2,4
	DIF 200	4.91450		4.99950	5.00000	5.00050		5.11063	ns	1,2,4
	DIF 266	3.66463		3.74963	3.75000	3.75038		3.85422	ns	1,2,4
	DIF 333	2.91470		2.99970	3.00000	3.00030		3.10038	ns	1,2,4
	DIF 400	2.41475		2.49975	2.50000	2.50025		2.59782	ns	1,2,4

<sup>1</sup>Guaranteed by design and characterization, not 100% tested in production.

<sup>2</sup>All Long Term Accuracy specifications are guaranteed with the assumption that the input clock complies with CK409/CK410/CK505 accuracy requirements. The 9DB403/803 itself does not contribute to ppm error.

<sup>3</sup> Driven by SRC output of main clock, PLL or Bypass mode

<sup>4</sup> Driven by CPU output of CK410/CK505 main clock, **Bypass mode only**



SRC Reference Clock			
Common Recommendations for Differential Routing	Dimension or Value	Unit	Figure
L1 length, route as non-coupled 50ohm trace	0.5 max	inch	1
L2 length, route as non-coupled 50ohm trace	0.2 max	inch	1
L3 length, route as non-coupled 50ohm trace	0.2 max	inch	1
Rs	33	ohm	1
Rt	49.9	ohm	1

Down Device Differential Routing			
L4 length, route as coupled microstrip 100ohm differential trace	2 min to 16 max	inch	1
L4 length, route as coupled stripline 100ohm differential trace	1.8 min to 14.4 max	inch	1

Differential Routing to PCI Express Connector			
L4 length, route as coupled microstrip 100ohm differential trace	0.25 to 14 max	inch	2
L4 length, route as coupled stripline 100ohm differential trace	0.225 min to 12.6 max	inch	2

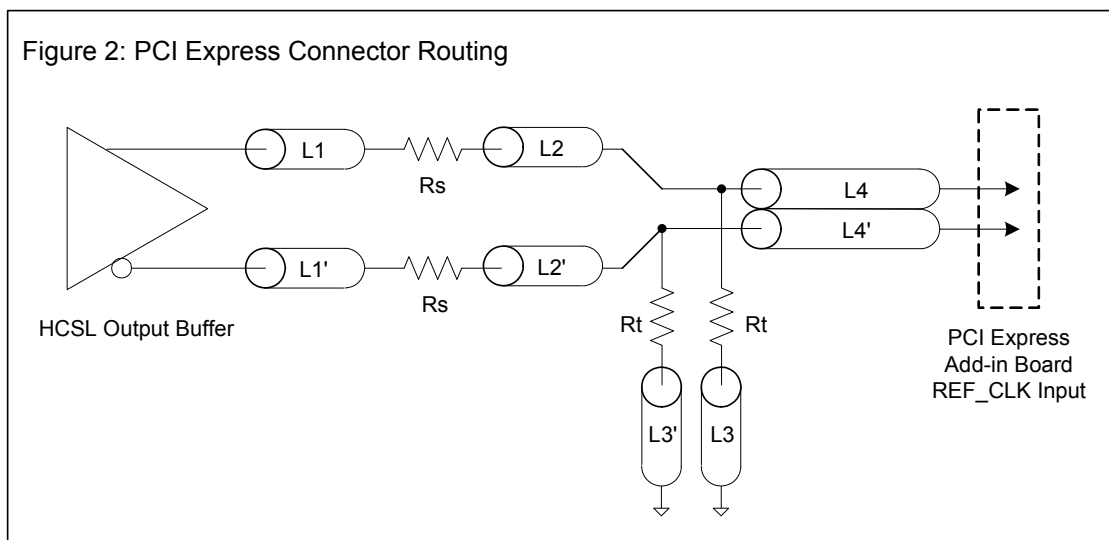
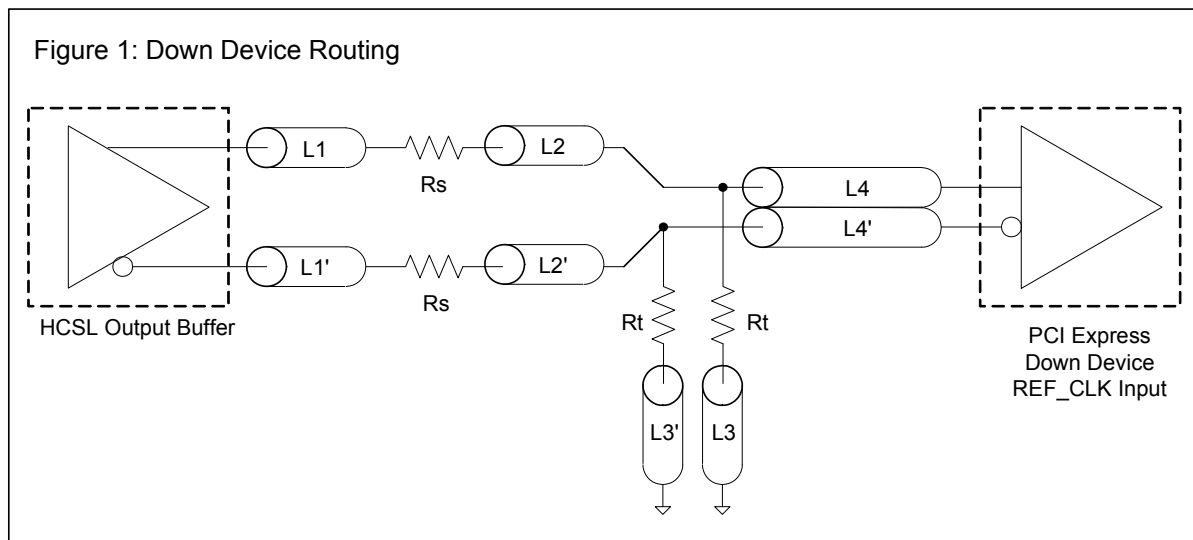

**Alternative Termination for LVDS and other Common Differential Signals (figure 3)**

Vdiff	Vp-p	Vcm	R1	R2	R3	R4	Note
0.45v	0.22v	1.08	33	150	100	100	
0.58	0.28	0.6	33	78.7	137	100	
0.80	0.40	0.6	33	78.7	none	100	ICS874003i-02 input compatible
0.60	0.3	1.2	33	174	140	100	Standard LVDS

R1a = R1b = R1  
R2a = R2b = R2

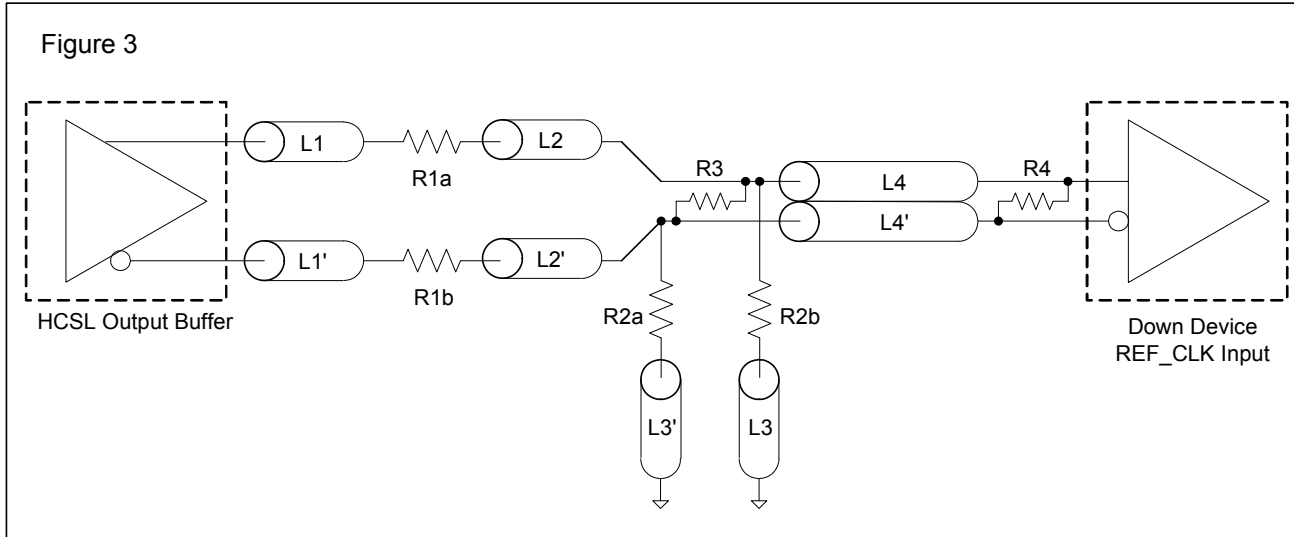

**Cable Connected AC Coupled Application (figure 4)**

Component	Value	Note
R5a, R5b	8.2K 5%	
R6a, R6b	1K 5%	
Cc	0.1 $\mu$ F	
Vcm	0.350 volts	

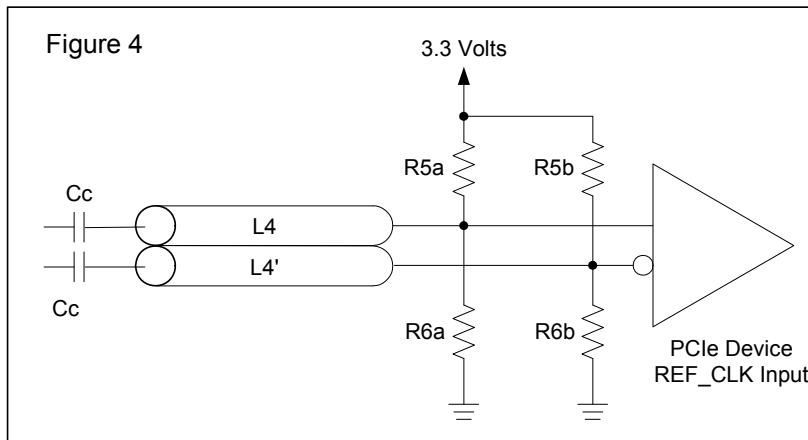

## General SMBus serial interface information for the ICS9DB403D

### How to Write:

- Controller (host) sends a start bit.
- Controller (host) sends the write address  $DC_{(h)}$
- ICS clock will **acknowledge**
- Controller (host) sends the beginning byte location = N
- ICS clock will **acknowledge**
- Controller (host) sends the data byte count = X
- ICS clock will **acknowledge**
- Controller (host) starts sending **Byte N through Byte N + X - 1**
- ICS clock will **acknowledge** each byte **one at a time**
- Controller (host) sends a Stop bit

### How to Read:

- Controller (host) will send start bit.
- Controller (host) sends the write address  $DC_{(h)}$
- ICS clock will **acknowledge**
- Controller (host) sends the beginning byte location = N
- ICS clock will **acknowledge**
- Controller (host) will send a separate start bit.
- Controller (host) sends the read address  $DD_{(h)}$
- ICS clock will **acknowledge**
- ICS clock will send the data byte count = X
- ICS clock sends **Byte N + X - 1**
- ICS clock sends **Byte 0 through byte X (if  $X_{(h)}$  was written to byte 8).**
- Controller (host) will need to acknowledge each byte
- Controller (host) will send a not acknowledge bit
- Controller (host) will send a stop bit

Index Block Write Operation		
Controller (Host)		ICS (Slave/Receiver)
T	starT bit	
Slave Address $DC_{(h)}$		
WR	WRite	
		ACK
Beginning Byte = N		
		ACK
Data Byte Count = X		
		ACK
Beginning Byte N		X Byte
◊		
◊		
◊		
Byte N + X - 1		
		ACK
P	stoP bit	

Index Block Read Operation		
Controller (Host)		ICS (Slave/Receiver)
T	starT bit	
Slave Address $DC_{(h)}$		
WR	WRite	
		ACK
Beginning Byte = N		
		ACK
RT	Repeat starT	
Slave Address $DD_{(h)}$		
RD	ReaD	
		ACK
		Data Byte Count = X
ACK		
		X Byte
ACK		
◊		
◊		
◊		
		Byte N + X - 1
N	Not acknowledge	
P	stoP bit	

**SMBus Table: Frequency Select Register, READ/WRITE ADDRESS (DC/DD)**

Byte 0	Pin #	Name	Control Function	Type	0	1	Default
Bit 7	-	PD_Mode	PD# drive mode	RW	driven	Hi-Z	0
Bit 6	-	STOP_Mode	DIF_Stop# drive mode	RW	driven	Hi-Z	0
Bit 5	-	Reserved	Reserved	RW	Reserved		X
Bit 4	-	Reserved	Reserved	RW	Reserved		X
Bit 3	-	Reserved	Reserved	RW	Reserved		X
Bit 2	-	PLL_BW#	Select PLL BW	RW	High BW	Low BW	1
Bit 1	-	BYPASS#	BYPASS#/PLL	RW	fan-out	ZDB	1
Bit 0	-	SRC_DIV#	SRC Divide by 2 Select	RW	x/2	1x	1

**SMBus Table: Output Control Register**

Byte 1	Pin #	Name	Control Function	Type	0	1	Default
Bit 7	-	Reserved	Reserved	RW	Reserved		1
Bit 6	22,23	DIF_6	Output Enable	RW	Disable	Enable	1
Bit 5	19,20	DIF_5	Output Enable	RW	Disable	Enable	1
Bit 4	-	Reserved	Reserved	RW	Reserved		1
Bit 3	-	Reserved	Reserved	RW	Reserved		1
Bit 2	9,10	DIF_2	Output Enable	RW	Disable	Enable	1
Bit 1	6,7	DIF_1	Output Enable	RW	Disable	Enable	1
Bit 0	-	Reserved	Reserved	RW	Reserved		1

**NOTE:** The SMBus Output Enable Bit must be '1' AND the respective OE pin must be active for the output to run!

**SMBus Table: OE Pin Control Register**

Byte 2	Pin #	Name	Control Function	Type	0	1	Default
Bit 7	-	Reserved	Reserved	RW	Reserved		0
Bit 6	22,23	DIF_6	DIF_6 Stoppable with DIFSTOP	RW	Free-run	Stoppable	0
Bit 5	19,20	DIF_5	DIF_5 Stoppable with DIFSTOP	RW	Free-run	Stoppable	0
Bit 4	-	Reserved	Reserved	RW	Reserved		0
Bit 3	-	Reserved	Reserved	RW	Reserved		0
Bit 2	9,1	DIF_2	DIF_2 Stoppable with DIFSTOP	RW	Free-run	Stoppable	0
Bit 1	6,7	DIF_1	DIF_1 Stoppable with DIFSTOP	RW	Free-run	Stoppable	0
Bit 0	-	Reserved	Reserved	RW	Reserved		0

**SMBus Table: Reserved Register**

Byte 3	Pin #	Name	Control Function	Type	0	1	Default
Bit 7			Reserved				X
Bit 6			Reserved				X
Bit 5			Reserved				X
Bit 4			Reserved				X
Bit 3			Reserved				X
Bit 2			Reserved				X
Bit 1			Reserved				X
Bit 0			Reserved				X

**SMBus Table: Vendor & Revision ID Register**

Byte 4	Pin #	Name	Control Function	Type	0	1	Default
Bit 7	-	RID3	REVISION ID	R	-	-	0
Bit 6	-	RID2		R	-	-	0
Bit 5	-	RID1		R	-	-	1
Bit 4	-	RID0		R	-	-	1
Bit 3	-	VID3	VENDOR ID	R	-	-	0
Bit 2	-	VID2		R	-	-	0
Bit 1	-	VID1		R	-	-	0
Bit 0	-	VID0		R	-	-	1

**SMBus Table: DEVICE ID**

Byte 5	Pin #	Name	Control Function	Type	0	1	Default
Bit 7	-	Device ID 7 (MSB)		RW	Device ID is 83 Hex for 9DB803 and 43 Hex for 9DB403		0
Bit 6	-	Device ID 6		RW			X
Bit 5	-	Device ID 5		RW			X
Bit 4	-	Device ID 4		RW			0
Bit 3	-	Device ID 3		RW			0
Bit 2	-	Device ID 2		RW			0
Bit 1	-	Device ID 1		RW			1
Bit 0	-	Device ID 0		RW			1

**SMBus Table: Byte Count Register**

Byte 6	Pin #	Name	Control Function	Type	0	1	Default
Bit 7	-	BC7	Writing to this register configures how many bytes will be read back.	RW	-	-	0
Bit 6	-	BC6		RW	-	-	0
Bit 5	-	BC5		RW	-	-	0
Bit 4	-	BC4		RW	-	-	0
Bit 3	-	BC3		RW	-	-	0
Bit 2	-	BC2		RW	-	-	1
Bit 1	-	BC1		RW	-	-	1
Bit 0	-	BC0		RW	-	-	1

Note: Polarities in timing diagrams are shown OE\_INV = 0. They are similar to OE\_INV = 1.

### PD#, Power Down

The PD# pin cleanly shuts off all clocks and places the device into a power saving mode. PD# must be asserted before shutting off the input clock or power to insure an orderly shutdown. PD is asynchronous active-low input for both powering down the device and powering up the device. When PD# is asserted, all clocks will be driven high, or tri-stated (depending on the PD# drive mode and Output control bits) before the PLL is shut down.

### PD# Assertion

When PD# is sampled low by two consecutive rising edges of DIF#, all DIF outputs must be held High, or tri-stated (depending on the PD# drive mode and Output control bits) on the next High-Low transition of the DIF# outputs. When the PD# drive mode bit is set to '0', all clock outputs will be held with DIF driven High with  $2 \times I_{REF}$  and DIF# tri-stated. If the PD# drive mode bit is set to '1', both DIF and DIF# are tri-stated.

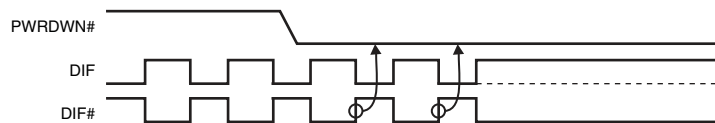

### PD# De-assertion

Power-up latency is less than 1 ms. This is the time from de-assertion of the PD# pin, or VDD reaching 3.3V, or the time from valid SRC\_IN clocks until the time that stable clocks are output from the device (PLL Locked). If the PD# drive mode bit is set to '1', all the DIF outputs must driven to a voltage of >200 mV within 300 us of PD# de-assertion.

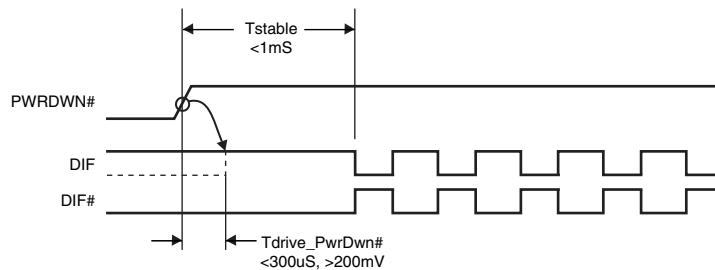

## SRC\_STOP#

The SRC\_STOP# signal is an active-low asynchronous input that cleanly stops and starts the DIF outputs. A valid clock must be present on SRC\_IN for this input to work properly. The SRC\_STOP# signal is de-bounced and must remain stable for two consecutive rising edges of DIF# to be recognized as a valid assertion or de-assertion.

### SRC\_STOP# - Assertion

Asserting SRC\_STOP# causes all DIF outputs to stop after their next transition (if the control register settings allow the output to stop). When the SRC\_STOP# drive bit is '0', the final state of all stopped DIF outputs is DIF = High and DIF# = Low. There is no change in output drive current. DIF is driven with  $6 \times I_{REF}$ . DIF# is not driven, but pulled low by the termination. When the SRC\_STOP# drive bit is '1', the final state of all DIF output pins is Low. Both DIF and DIF# are not driven.

### SRC\_STOP# - De-assertion (transition from '0' to '1')

All stopped differential outputs resume normal operation in a glitch-free manner. The de-assertion latency to active outputs is 2-6 DIF clock periods, with all DIF outputs resuming simultaneously. If the SRC\_STOP# drive control bit is '1' (tri-state), all stopped DIF outputs must be driven High ( $>200$  mV) within 10 ns of de-assertion.

### SRC\_STOP\_1 (SRC\_Stop = Driven, PD = Driven)

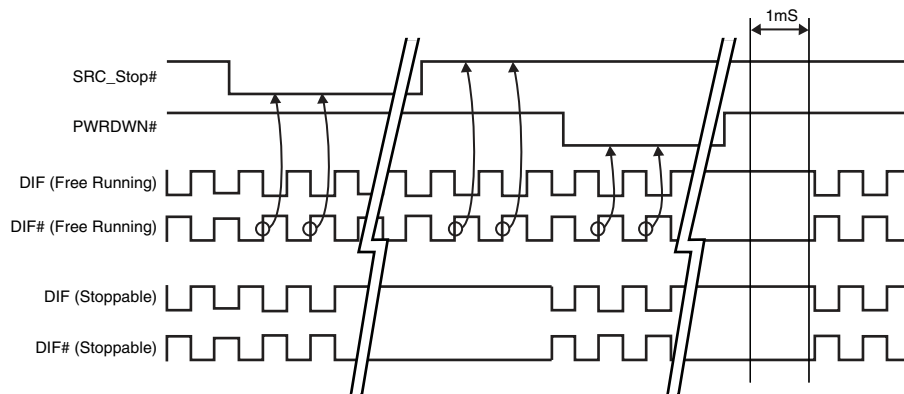

### SRC\_STOP\_2 (SRC\_Stop = Tristate, PD = Driven)

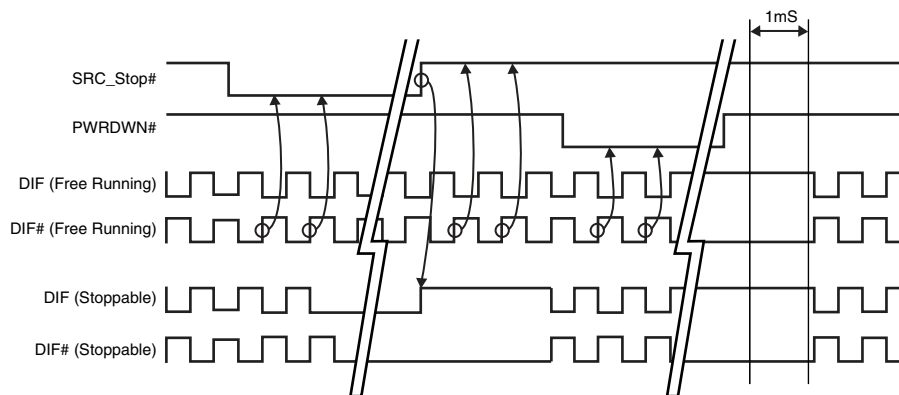

**SRC\_STOP\_3 (SRC\_Stop = Driven, PD = Tristate)**

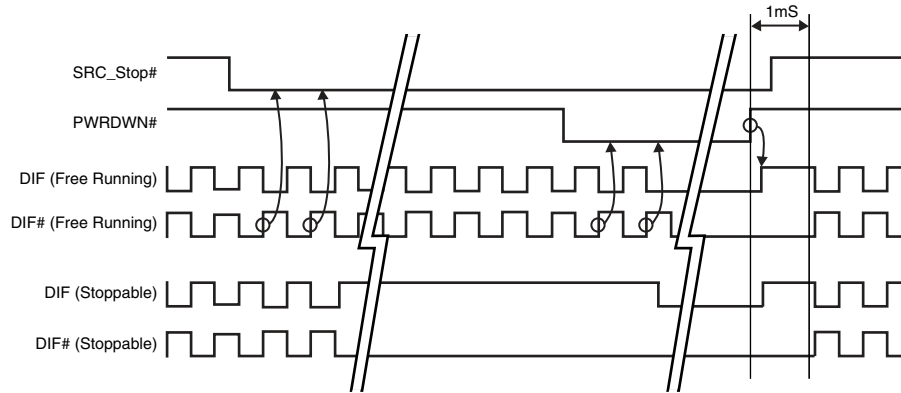

**SRC\_STOP\_4 (SRC\_Stop = Tristate, PD = Tristate)**

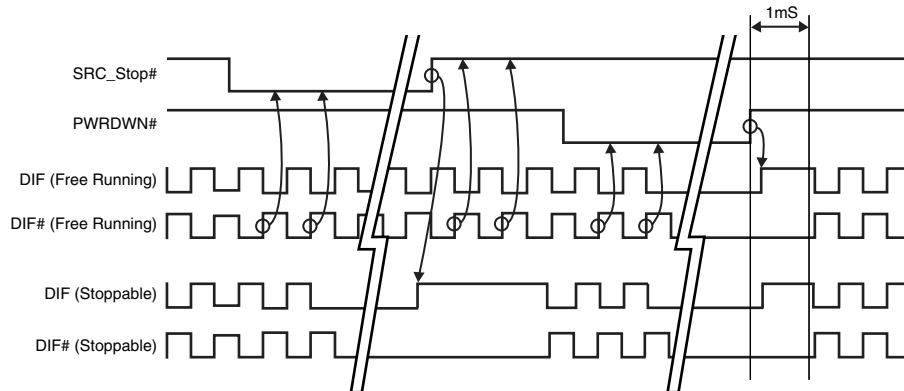



**28-pin SSOP Package Dimensions**



**209 mil SSOP**

**209 mil SSOP**

SYMBOL	In Millimeters COMMON DIMENSIONS		In Inches COMMON DIMENSIONS	
	MIN	MAX	MIN	MAX
A	--	2.00	--	.079
A1	0.05	--	.002	--
A2	1.65	1.85	.065	.073
b	0.22	0.38	.009	.015
c	0.09	0.25	.0035	.010
D	SEE VARIATIONS		SEE VARIATIONS	
E	7.40	8.20	.291	.323
E1	5.00	5.60	.197	.220
e	0.65 BASIC		0.0256 BASIC	
L	0.55	0.95	.022	.037
N	SEE VARIATIONS		SEE VARIATIONS	
alpha	0°	8°	0°	8°

**VARIATIONS**

N	D mm.		D (inch)	
	MIN	MAX	MIN	MAX
28	9.90	10.50	.390	.413

Reference Doc.: JEDEC Publication 95, MO-150

10-0033

## 28-pin TSSOP Package Dimensions

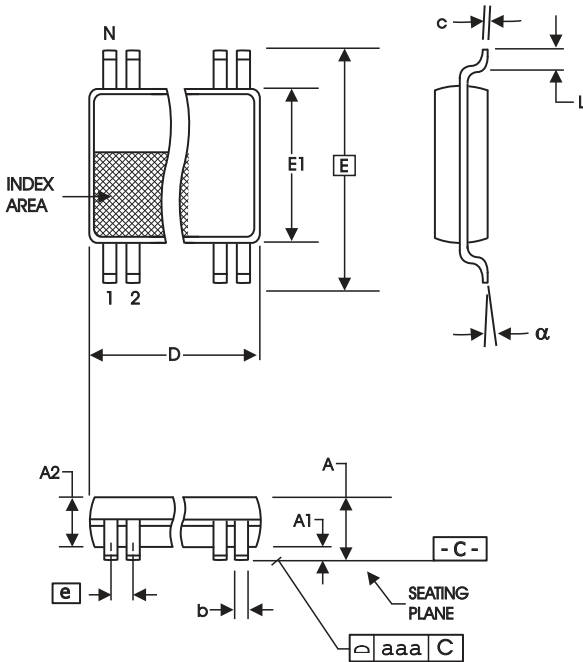

**4.40 mm. Body, 0.65 mm. Pitch TSSOP**  
**(173 mil) (25.6 mil)**

SYMBOL	In Millimeters COMMON DIMENSIONS		In Inches COMMON DIMENSIONS	
	MIN	MAX	MIN	MAX
A	--	1.20	--	.047
A1	0.05	0.15	.002	.006
A2	0.80	1.05	.032	.041
b	0.19	0.30	.007	.012
c	0.09	0.20	.0035	.008
D	SEE VARIATIONS		SEE VARIATIONS	
E	6.40 BASIC		0.252 BASIC	
E1	4.30	4.50	.169	.177
e	0.65 BASIC		0.0256 BASIC	
L	0.45	0.75	.018	.030
N	SEE VARIATIONS		SEE VARIATIONS	
alpha	0°	8°	0°	8°
aaa	--	0.10	--	.004

### VARIATIONS

N	D mm.		D (inch)	
	MIN	MAX	MIN	MAX
28	9.60	9.80	.378	.386

Reference Doc.: JEDEC Publication 95, MO-153

10-0035

## Ordering Information

Part / Order Number	Marking	Shipping Packaging	Package	Temperature
9DB403DGLF	9DB403DGLF	Tubes	28-pin TSSOP	0 to +70° C
9DB403DGLFT	9DB403DGLF	Tape and Reel	28-pin TSSOP	0 to +70° C
9DB403DGILF	9DB403DGILF	Tubes	28-pin TSSOP	-40 to +85° C
9DB403DGILFT	9DB403DGILF	Tape and Reel	28-pin TSSOP	-40 to +85° C
9DB403DFLF	9DB403DFLF	Tubes	28-pin SSOP	0 to +70° C
9DB403DFLFT	9DB403DFLF	Tape and Reel	28-pin SSOP	0 to +70° C
9DB403DFILF	9DB403DFILF	Tubes	28-pin SSOP	-40 to +85° C
9DB403DFILFT	9DB403DFILF	Tape and Reel	28-pin SSOP	-40 to +85° C

"LF" denotes Pb-free package, RoHS compliant

"D" is the revision designator (will not correlate to datasheet revision)

## Revision History

Rev.	Issue Date	Description	Page #
I	11/26/2008	Updated SMBus table - Byte0:Byte3.	11
J	2/6/2009	Added Industrial temp. specs and ordering information.	Various
K	7/13/2009	Updated general description and block diagram	1
L	10/7/2009	1. Clarified that Vih and Vil values were for Single ended inputs 2. Added separate Idd values for the 9DB403 3. Added Differential Clock input parameters.	Various
M	1/27/2011	Updated Termination Figure 4	10
N	5/6/2011	1. Update pin 1 pin-name and pin description from VDD to VDDR. This highlights that optimal performance is obtained by treating VDDR as in analog pin. This is a document update only, there is no silicon change.	Various
P	8/27/2012	Updated Vswing conditions to include "single-ended measurement"	5
Q	9/18/2012	Updated Byte 2, bits 1, 2, 5 and 6 per char review. Outputs can be programmed with Byte 2 to be Stoppable or Free-Run with DIF_Stop pin, not the OE pins.	12
R	11/1/2012	Updated Input-to-Output Skew max value (Bypass Mode condition only) from 4500ps to 5000ps per latest characterization data.	7

## IMPORTANT NOTICE AND DISCLAIMER

RENESAS ELECTRONICS CORPORATION AND ITS SUBSIDIARIES (“RENESAS”) PROVIDES TECHNICAL SPECIFICATIONS AND RELIABILITY DATA (INCLUDING DATASHEETS), DESIGN RESOURCES (INCLUDING REFERENCE DESIGNS), APPLICATION OR OTHER DESIGN ADVICE, WEB TOOLS, SAFETY INFORMATION, AND OTHER RESOURCES “AS IS” AND WITH ALL FAULTS, AND DISCLAIMS ALL WARRANTIES, EXPRESS OR IMPLIED, INCLUDING, WITHOUT LIMITATION, ANY IMPLIED WARRANTIES OF MERCHANTABILITY, FITNESS FOR A PARTICULAR PURPOSE, OR NON-INFRINGEMENT OF THIRD PARTY INTELLECTUAL PROPERTY RIGHTS.

These resources are intended for developers skilled in the art designing with Renesas products. You are solely responsible for (1) selecting the appropriate products for your application, (2) designing, validating, and testing your application, and (3) ensuring your application meets applicable standards, and any other safety, security, or other requirements. These resources are subject to change without notice. Renesas grants you permission to use these resources only for development of an application that uses Renesas products. Other reproduction or use of these resources is strictly prohibited. No license is granted to any other Renesas intellectual property or to any third party intellectual property. Renesas disclaims responsibility for, and you will fully indemnify Renesas and its representatives against, any claims, damages, costs, losses, or liabilities arising out of your use of these resources. Renesas' products are provided only subject to Renesas' Terms and Conditions of Sale or other applicable terms agreed to in writing. No use of any Renesas resources expands or otherwise alters any applicable warranties or warranty disclaimers for these products.

(Disclaimer Rev.1.0 Mar 2020)

### Corporate Headquarters

TOYOSU FORESIA, 3-2-24 Toyosu,  
Koto-ku, Tokyo 135-0061, Japan  
[www.renesas.com](http://www.renesas.com)

### Contact Information

For further information on a product, technology, the most up-to-date version of a document, or your nearest sales office, please visit:  
[www.renesas.com/contact/](http://www.renesas.com/contact/)

### Trademarks

Renesas and the Renesas logo are trademarks of Renesas Electronics Corporation. All trademarks and registered trademarks are the property of their respective owners.