

REV.	DATE	ECR NO.	DESCRIPTION
NC	04/02/01	XXXXXX	INITIAL RELEASE
A	02/03/10	2020	ADDED RECOMMENDED PCB LAYOUT
B	07/11/11	2197	CHANGE THE DESCRIPTION TO " SMA END LAUNCH RECEPT. JACK"

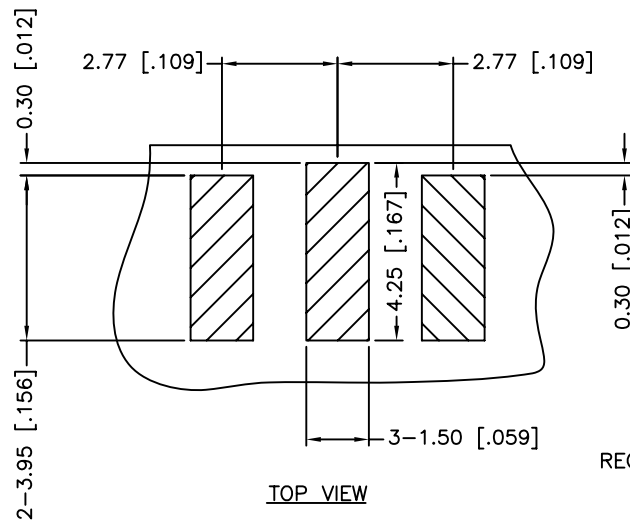

RECOMMENDED PCB LAYOUT

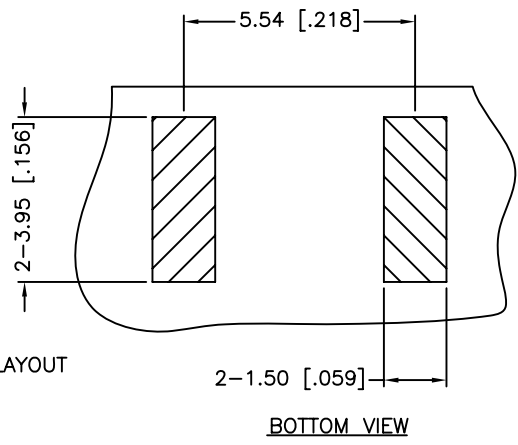

BOTTOM VIEW

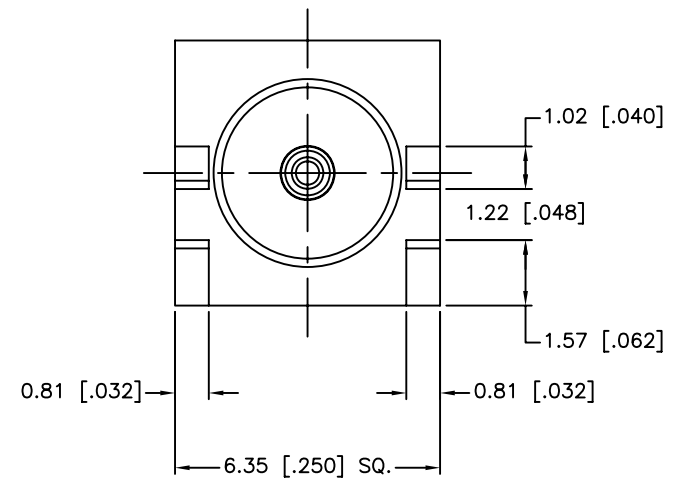
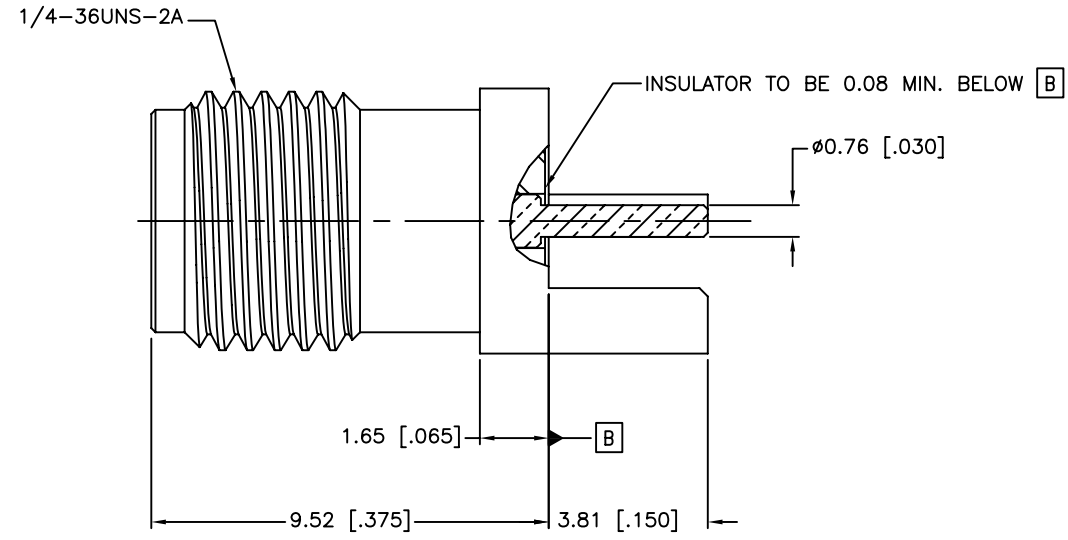

UNLESS OTHERWISE SPECIFIED DIMENSIONS ARE IN MILLIMETERS. DIMENSIONS IN [] ARE IN INCHES AND FOR CUSTOMER REFERENCE ONLY.

UNLESS OTHERWISE SPECIFIED TOLERANCES FOR MILLIMETERS ARE:
0.5 - 8mm ± 0.20mm
8 - 30mm ± 0.40mm
30 - 120mm ± 0.50mm

UNLESS OTHERWISE SPECIFIED TOLERANCES FOR INCHES ARE:
.020 - .315 = ± 0.007"
.315 - 1.180 = ± 0.015"
1.180 - 4.724 = ± 0.020"

DO NOT SCALE DRAWING

APPROVALS		DATE
DRAWN	M.ZHANG	07/11/11
CHECKED		
ISSUED		
SHEET	1 OF 1	
CAD FILE	C:/CONNEX/132323.DWG	

Amphenol Connex

PART DESCRIPTION			
SMA END LAUNCH RECEPT. JACK (.042" BOARD THICKNESS)			
PART NO.			
132323			
DWG. NO.	132323.DWG	REV.	B
SIZE	A	SCALE	NA

QTY	FINISH	MATERIAL	DESCRIPTION
1	GOLD	BRASS	BODY
1	NATURAL	PTFE	INSULATOR
1	GOLD	BER. COPPER	CONTACT PIN