

**BCD-3951-17-4-006 v.01b****DOME TWEETER**

STAPEZ™ brand dome tweeter.

FEATURE HIGHLIGHTS:

- Wide dispersions and sweet imaging
- Ferrofluid for cooling and optimal mechanical damping
- High power handling : 30W (continuous), 90W (transient)
- Treated cloth dome diaphragm
- Aluminum alloy voice-coil bobbin
- Over-sized Neodymium (NdFeB) magnet motor

APPLICATIONS:

- General two-way or three-way tweeter applications.
- Speaker array.
- MTM configuration.
- High clarity audio-conference phones.
- Music instruments.
- (Able to increase continuous power handling by adding a heat-sink on the back U-cup.)



1:1 size in A4 paper



DRAWINGS AND DIMENSIONS:

All units are in mm unless specified.

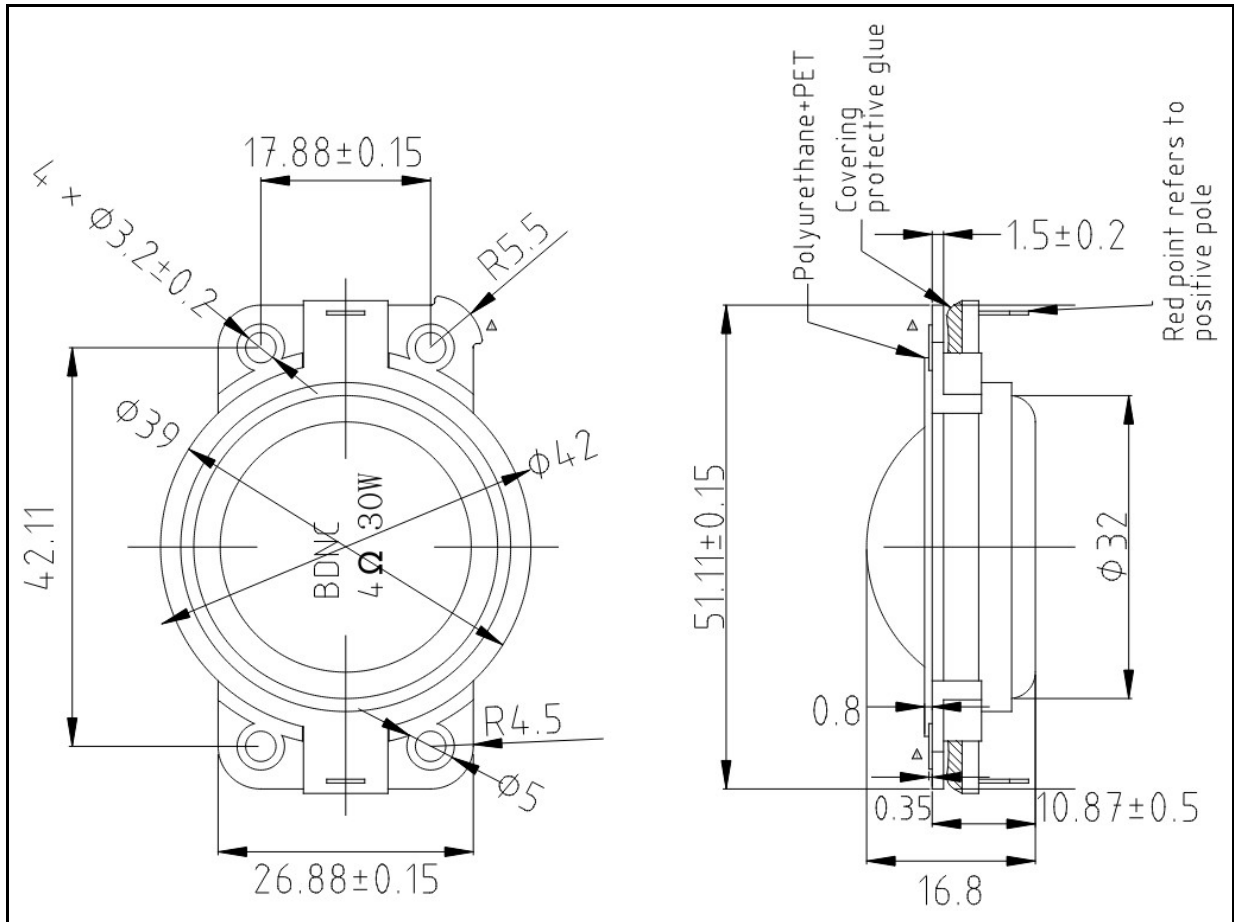



IMPEDANCE CURVE VS FREQUENCY:

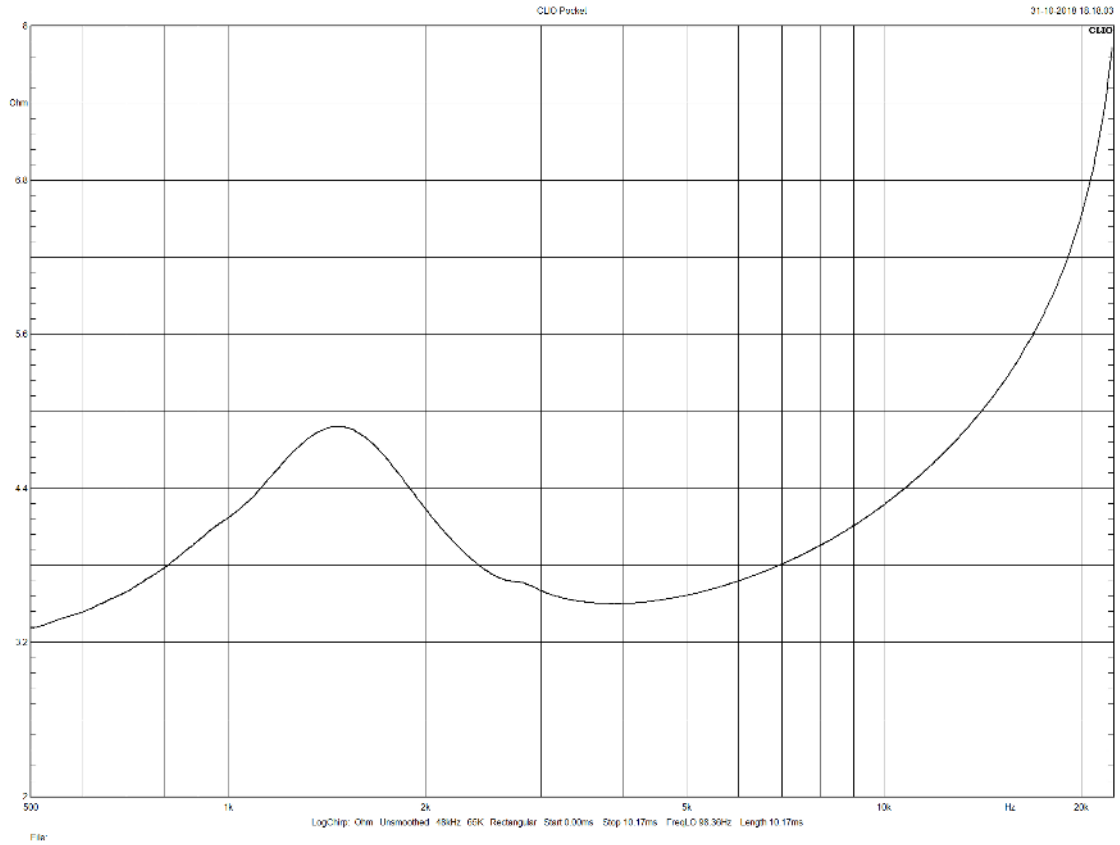

FREQUENCY RESPONSE

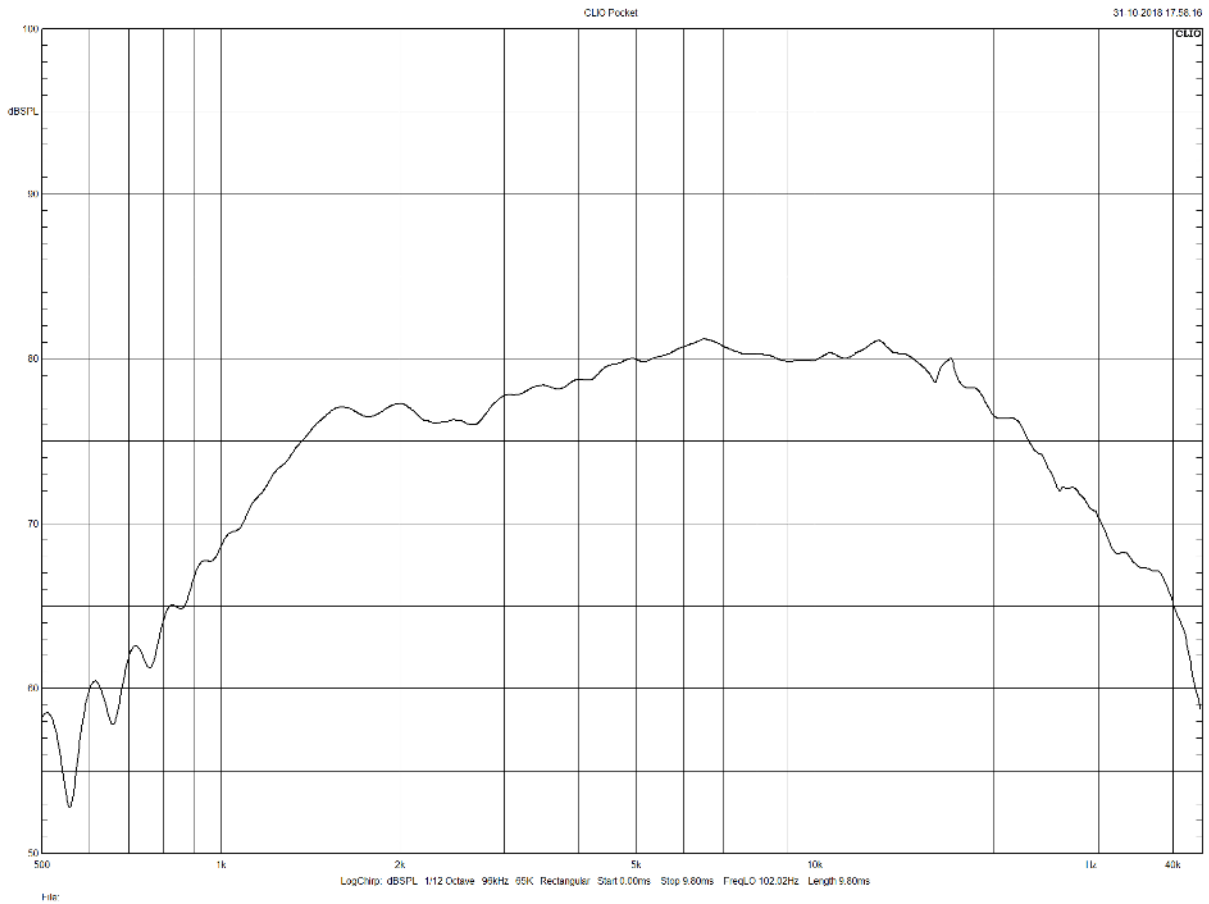



ELECTRICAL, ACOUSTICAL, AND THIELE/SMALL PARAMETERS:

Parameter	Min.	Typical	Max.	Testing Conditions
DC Resistance (Re)		4 ohm		
Resonance Frequency (Fs)		1200Hz		
Continuous Power (thermal)		30W		Pink, 3kHz HPF, 4 th Linkwitz-Riley
Max. Power (transient)		90W		Pink, 3kHz HPF, 200ms
Excursion, peak-to-peak (Xmax)		-		
Moving Mass (Mms)		0.34g		
Effective Radiating-area (Sd)		7 cm ²		
Force Factor (BL)		-		
Specific Force Factor (BL/√Re)		-		
Compliance, free-air (Cms)		-		
Eqv. Compliance Volume (Vas)		-		
Voice Coil Inductance (Le)		0.19mH		
Diaphragm Displacement Volume, peak-to-peak(Vd)		-		
Sensitivity (1W/1m@1kHz)		86dBSpl		
NdFeB magnet rating		N38		
NdFeB magnet weight		5.5g		
Voice-coil magnet wire weight		0.15g		
Driver Weight		60.5g		
Voice-coil magnet wire grade		EISV		
Magnet wire material		copper		
Max. Voice-coil Temperature		180°C		
Operating Temperature		-10 to 40 °C		
Storage Temperature		-20 to 70 °C		