

REVISIONS

P	LTR	DESCRIPTION	DATE	DWN	APVD
	A	INITIAL RELEASE	14APR2021	SR	CB

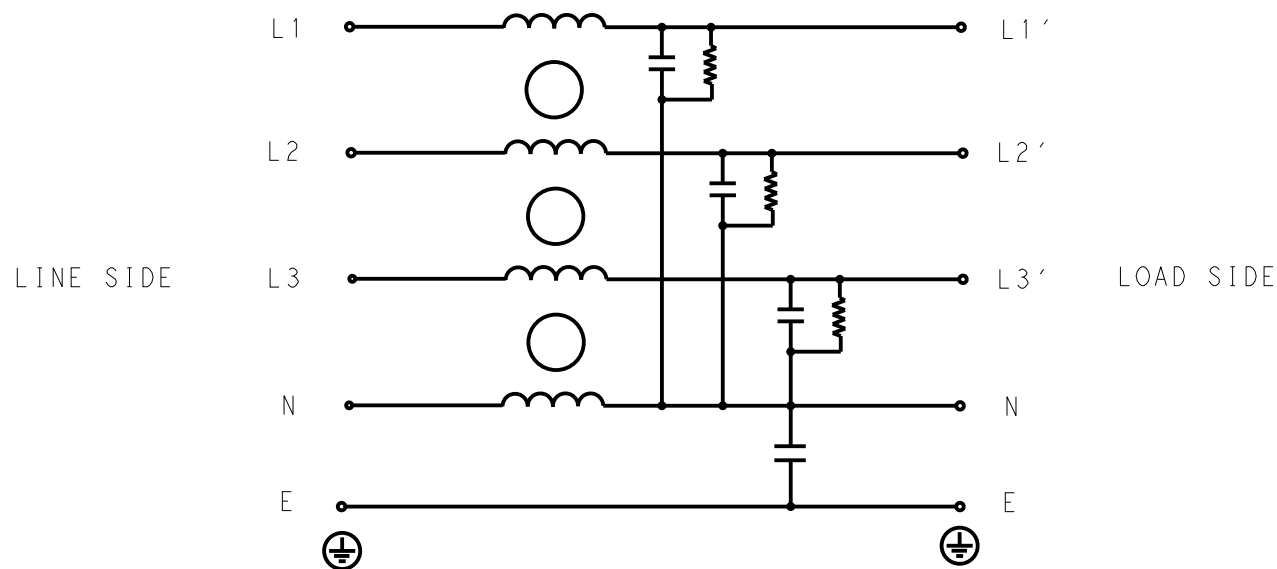

SCHEMATIC

TYPICAL INSERTION LOSS
COMMON MODE 50/50Ω; DIFFERENTIAL MODE 50/50Ω

MHz	0.01	0.05	0.15	0.5	1	3	5	10	30
CM	4	5	10	25	30	39	50	38	24
DM	11	18	22	39	45	28	24	17	15

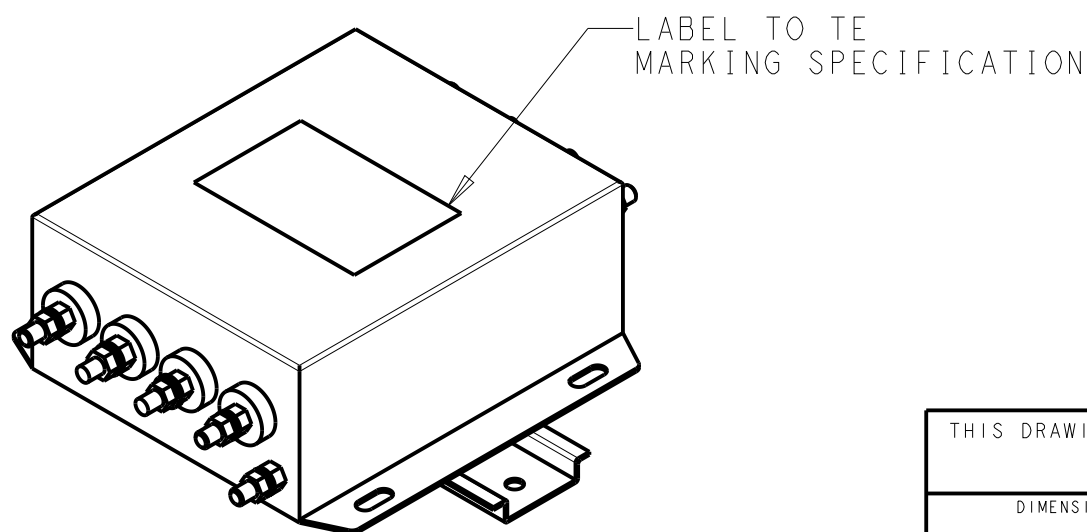

SAFETY ORGANIZATIONS

THIS FILTER WILL BE FORMALLY RECOGNIZED, CERTIFIED OR APPROVED BY THE LISTED AGENCY. THEREFORE, ALL TEST/REQUIREMENTS SPECIFIED IN THE LATEST REVISION OF THE FOLLOWING AGENCY STANDARDS WILL BE MET:

UL APPROVED 60A 520V 50Hz/60Hz 40°C
 CSA PENDING 60A 520V 50Hz/60Hz 40°C

OPERATING SPECIFICATION

LINE CURRENT/VOLTAGE: 60A, 520VAC
LINE FREQUENCY: 50/60Hz

MAXIMUM LEAKAGE CURRENT: 5mA @ 230VAC, 50Hz

OPERATING AMBIENT TEMPERATURE RANGE @ RATED CURRENT: -25°C TO +40°C

IN AN AMBIENT, T_a, HIGHER THAN 40°C, THE MAXIMUM OPERATING CURRENT, I_o, IS AS FOLLOWS:

$$I_o = I_r \sqrt{\frac{85 - T_a}{45}}$$

RELIABILITY SPECIFICATIONS

STORAGE TEMPERATURE: -40°C TO +85°C
HUMIDITY: 21 DAYS @ 40°C AND 95% RH

TEST SPECIFICATIONS

INDUCTANCE, NOMINAL: 0.2 mH

CAPACITANCE @ 1kHz

LINE TO GROUND, NOMINAL: 22nF
LINE TO NEUTRAL, NOMINAL: 470nF

DISCHARGE RESISTOR

L/G I.R. 2MΩ 2W
 L/L I.R. 2MΩ 2W
 L/N I.R. 1MΩ 2W
 N/G I.R. 680KΩ 2W
 IR (NO DISCHARGE RESISTOR) 20°C, 50% RH AND 100VDC, MIN: 6MΩ

RECOMMENDED RECEIVING INSPECTION HIPOT

LINE TO GROUND FOR 1 MINUTE: 2856VDC
LINE TO LINE FOR 1 MINUTE: 2236VDC
LINE TO NEUTRAL FOR 1 MINUTE: 1290VDC

FILTER APPROVAL

THE BEST WAY TO SELECT AND QUALIFY A FILTER IS FOR YOUR ENGINEERING TO TEST THE UNIT IN YOUR EQUIPMENT.

THIS DRAWING IS A CONTROLLED DOCUMENT.		DWN SUPREETH R 14APR2021		
		CHK CHRIS BOLLE 14APR2021		
		APVD CHRIS BOLLE 14APR2021		
		NAME POWER LINE FILTER FOR DIN RAIL 35 INSTALLATION 60KES6BFPWHM		
DIMENSIONS: mm		TOLERANCES UNLESS OTHERWISE SPECIFIED:		PRODUCT SPEC -
		0 PLC ±- 1 PLC ±0.5 2 PLC ±0.40 3 PLC ±0.130 4 PLC ±0.0500 ANGLES ±-		APPLICATION SPEC -
MATERIAL -		FINISH -		WEIGHT -
		CUSTOMER DRAWING		SCALE 1:2 SHEET 1 OF 2 REV A

© 2021 TE Connectivity. All Rights Reserved.

NOTE 1 GROUND CONNECTION:
 FOR ELECTRICAL SAFETY AND FILTER PERFORMANCE
 UNIT MUST HAVE A GOOD GROUND CONNECTION.
 TORQUE OUTER TERMINAL /GROUND NUTS: 2.5-3Nm

NOTE 2 INPUT OUTPUT CONNECTION TERMINAL
 AWG SIZE: XXX
 THREADED BOLT SIZE FOR TERMINAL: M6
 THREADED BOLT SIZE FOR GROUND: M6

NOTE 3 SUPPLIED WITH DIN RAIL BRACKET.

NOTE 4 DRAWING SHOWS DIN RAIL FOR REFERENCE ONLY.

REVISIONS					
P	LTR	DESCRIPTION	DATE	DWN	APVD
		SEE SHEET 1			

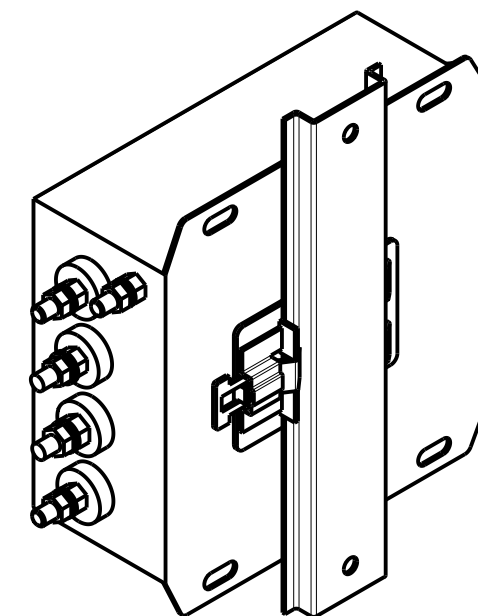
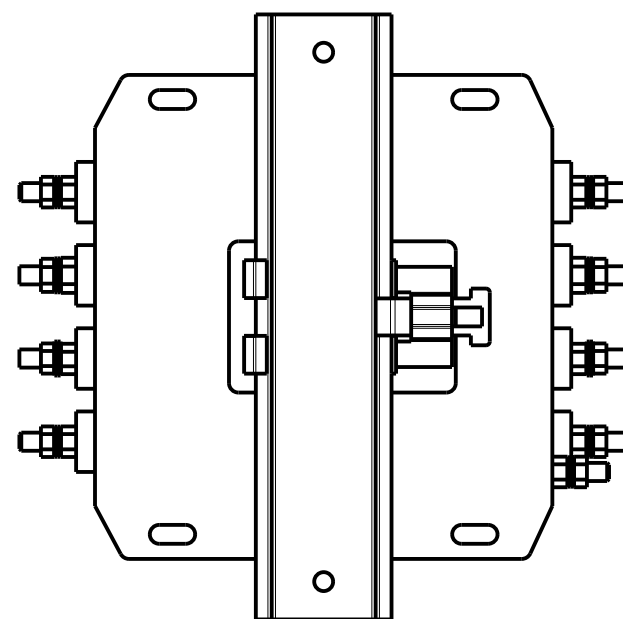
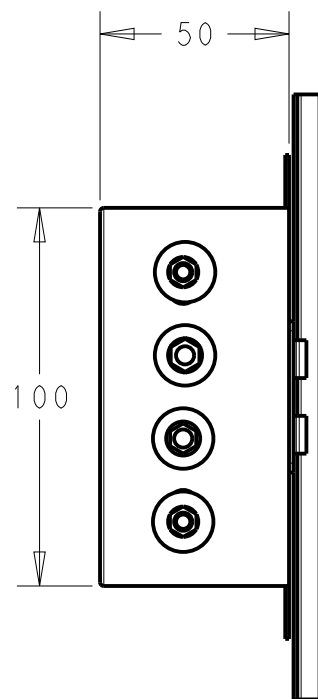
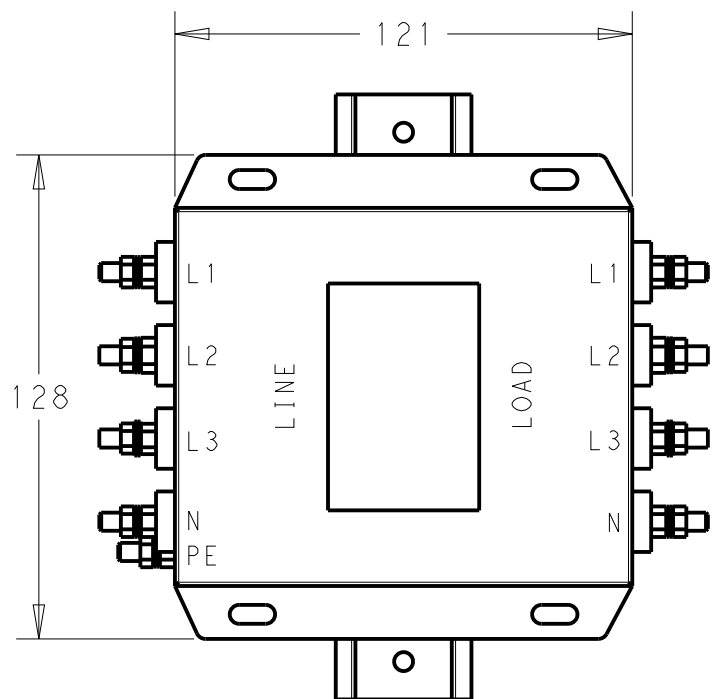

REAR SIDE

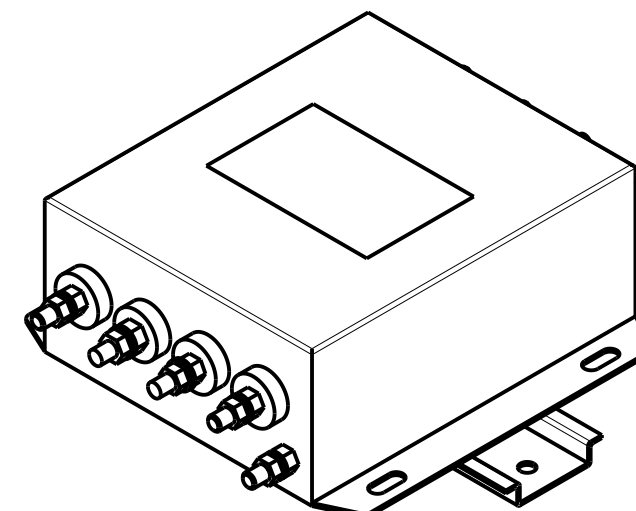

FRONT SIDE

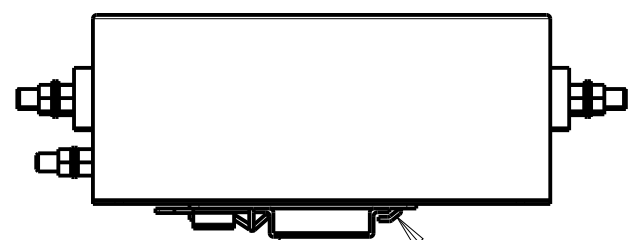

DIN RAIL BRACKET

DIN 35 BRACKET

THIS DRAWING IS A CONTROLLED DOCUMENT.		DWN SUPREETH R 14APR2021				
		CHK CHRIS BOLLE 14APR2021				
		APVD CHRIS BOLLE 14APR2021	NAME POWER LINE FILTER FOR DIN RAIL 35 INSTALLATION 60KES6BFPWHM			
DIMENSIONS: mm		PRODUCT SPEC -	SIZE A3	CAGE CODE 00779	DRAWING NO C-7-1609966-3	RESTRICTED TO -
TOLERANCES UNLESS OTHERWISE SPECIFIED:		APPLICATION SPEC -	SCALE 1:2		SHEET 2 OF 2	REV A
MATERIAL -		WEIGHT -	CUSTOMER DRAWING			
FINISH -						