

EZ-BLE™ PSOC® EVALUATION BOARD

CYBLE-214015-EVAL



The EZ-BLE™ PSOC® Evaluation Board (CYBLE-214015-EVAL) enables you to evaluate and develop applications on the EZ-BLE PSOC Module (CYBLE-214015-01). The EZ-BLE PSOC Module is a fully-integrated, fully-certified, 11 mm x 11 mm x 1.8 mm, programmable, Bluetooth® Smart module designed to reduce your time-to-market.

For more information visit:

www.cypress.com/EZ-BLEModule - The EZ-BLE Module home page.

www.cypress.com/EZ-BLEEval - The EZ-BLE PSOC Evaluation Board kit page.

www.cypress.com/go/AN96841 - The getting started guide.

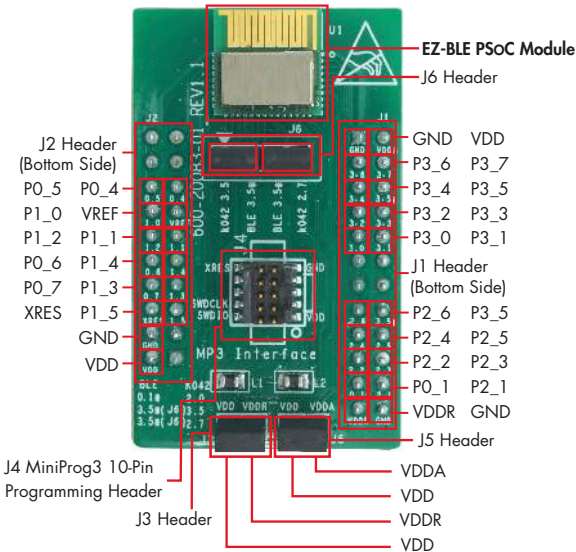
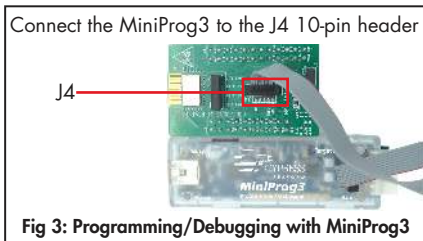
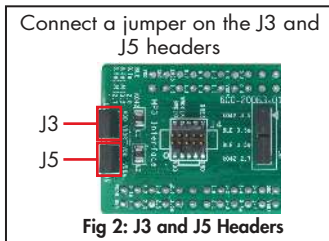

Fig 1: CYBLE-214015-EVAL Pinout Description

Note: To use the CYBLE-214015-EVAL you must separately purchase either the CY8CKIT-002 MINIPROG3 or the CY8CKIT-042-BLE BLE PIONEER KIT.

EZ-BLE™ PSoC® EVALUATION BOARD

1: Connect the CYBLE-214015-EVAL to the CY8CKIT-002 (MiniProg3)



OR

Plug the CYBLE-214015-EVAL on the CY8CKIT-042-BLE baseboard.

Note: Jumpers on CYBLE-214015-EVAL's J3 or J5 headers can be connected or disconnected.



Fig 4: Programming and debugging with CY8CKIT-042-BLE Pioneer Kit Baseboard

Pin Mapping between CY8CKIT-042-BLE (Base) and CYBLE-214015-EVAL (Eval)							
(Base)	(Eval)	(Base)	(Eval)	(Base)	(Eval)	(Base)	(Eval)
GND	GND	P0_7	P0_7	P2_1	P2_1	P3_1	P3_1
VDDD, VDDA	VDD	P1_0	P1_0	P2_2	P2_2	P3_2	P3_2
VDDR	VDDR	P1_1	P1_1	P2_3	P2_3	P3_3	P3_3
XRES	XRES	P1_2	P1_2	P2_4	P2_4	P3_4	P3_4
VREF	VREF	P1_3	P1_3	P2_5	P2_5	P3_5 ¹	P3_5 ¹
PO_4	PO_4	P1_4	P1_4	P2_6	P2_6	P3_6	P3_6
PO_5	PO_5	P1_5	P1_5	P2_7 ¹	P3_5 ¹	P3_7	P3_7
PO_6	PO_6	P2_0	PO_1	P3_0	P3_0		

¹ The J6 header provides flexibility to route P3_5 of the EZ-BLE Module to the P2_7 and/or P3_5 connections of the Pioneer Baseboard.

2: Create a project using the CYBLE-214015-01 MPN and program/debug using PSoC® Creator™ 3.3 DP1.

The EZ-BLE PSoC Module is qualified for the Bluetooth 4.2 specification and is certified for the 2.4 GHz unlicensed frequency range in USA (FCC), Canada (IC), Europe (CE), Japan (TELEC) and Korea (KC).

Visit www.cypress.com/go/support for technical support