300 mA LDO REGULATOR

No.EA-236-220901

OUTLINE

The RP114x is a CMOS-based voltage regulator IC with high output voltage accuracy, low supply current, low dropout, and high ripple rejection. This IC consists of a voltage reference unit, an error amplifier, resistors for setting output voltage, a short current limit circuit, a chip enable circuit, and so on. The RP114x features a minimum input voltage from 1.4V and the output voltage, which can be set from 0.8V to 3.6V (in 0.1V step). The output voltage of this IC is internally fixed. This IC perform with low dropout voltage due to built-in transistor with low ON resistance. Low supply current and a chip enable function prolong the battery life of each system. The ripple rejection, line transient response and load transient response of the RP114x is excellent, thus this IC is very suitable for the power supply for hand-held communication equipment. Since the packages for this IC are DFN(PL)1010-4、DFN(PL)1010-4B、SC-88A、SOT-23-5, therefore high density mounting of the IC on boards is possible.

FEATURES

- Supply Current..... Typ. 50 μ A
- Standby Current Typ. 0.1 μ A
- Input Voltage Range 1.4V to 5.25V
- Output Voltage Range⁽¹⁾ 0.8V to 3.6V (0.1V steps)
- Output Voltage Accuracy $\pm 1.0\%$ ($V_{SET} > 2.0V$, $T_a = 25^\circ C$)
- Temperature-Drift Coefficient of Output Voltage..... Typ. ± 80 ppm/ $^\circ C$
- Dropout Voltage..... Typ. 0.25V ($I_{OUT} = 300mA$, $V_{SET} = 2.8V$)
- Ripple Rejection Typ. 75dB ($f = 1kHz$)
- Line Regulation..... Typ. 0.02%/V
- Packages DFN(PL)1010-4、DFN(PL)1010-4B、
SC-88A、SOT-23-5
- Built-in Fold Back Protection Circuit..... Typ. 60mA (Current at short mode)
- Ceramic capacitors are recommended to be used with this IC 1.0 μ F or more

APPLICATIONS

- Power source for portable communication equipment.
- Power source for electrical appliances such as cameras, VCRs and camcorders.
- Power source for battery-powered equipment.

⁽¹⁾ For other voltages, please refer to *Product-specific Electrical Characteristics*.

SELECTION GUIDE

The set output voltage, the auto discharge function⁽¹⁾, and the package type for the ICs are user-selectable options.

Product Name	Package	Quantity per Reel	Pb Free	Halogen Free
RP114Kxx1*(y)-TR	DFN(PL)1010-4	10,000 pcs	Yes	Yes
RP114Kxx1*(y)-TRB	DFN(PL)1010-4B	10,000 pcs	Yes	Yes
RP114Qxx2*(y)-TR-FE	SC-88A	3,000 pcs	Yes	Yes
RP114Nxx1*(y)-TR-FE	SOT-23-5	3,000 pcs	Yes	Yes

xx: Specify the set output voltage within the range of 0.8 V (08) to 3.6 V (36) in 0.1 V step.

(y): If the output voltage includes the 3rd digit, indicate the digit of 0.01V.

Ex. If the output voltage is 1.25V, RP114K121*5-TR

If the output voltage is 1.85V, RP114K181*5-TR

*: Specify a combination of the CE pin polarity and the auto-discharge function.

(B) "H" Active, without Auto-Discharge function

(D) "H" Active, with Auto-Discharge function

BLOCK DIAGRAMS

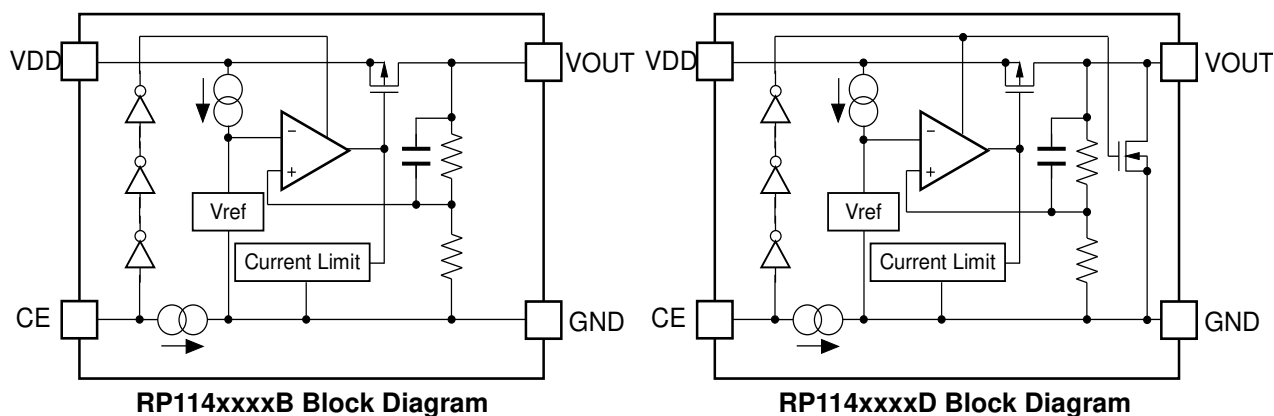

⁽¹⁾ Auto-Discharge function quickly lowers the output voltage to 0V by releasing the electrical charge in the external capacitor when the chip enable signal is switched from the active mode to the standby mode.

PIN DESCRIPTIONS

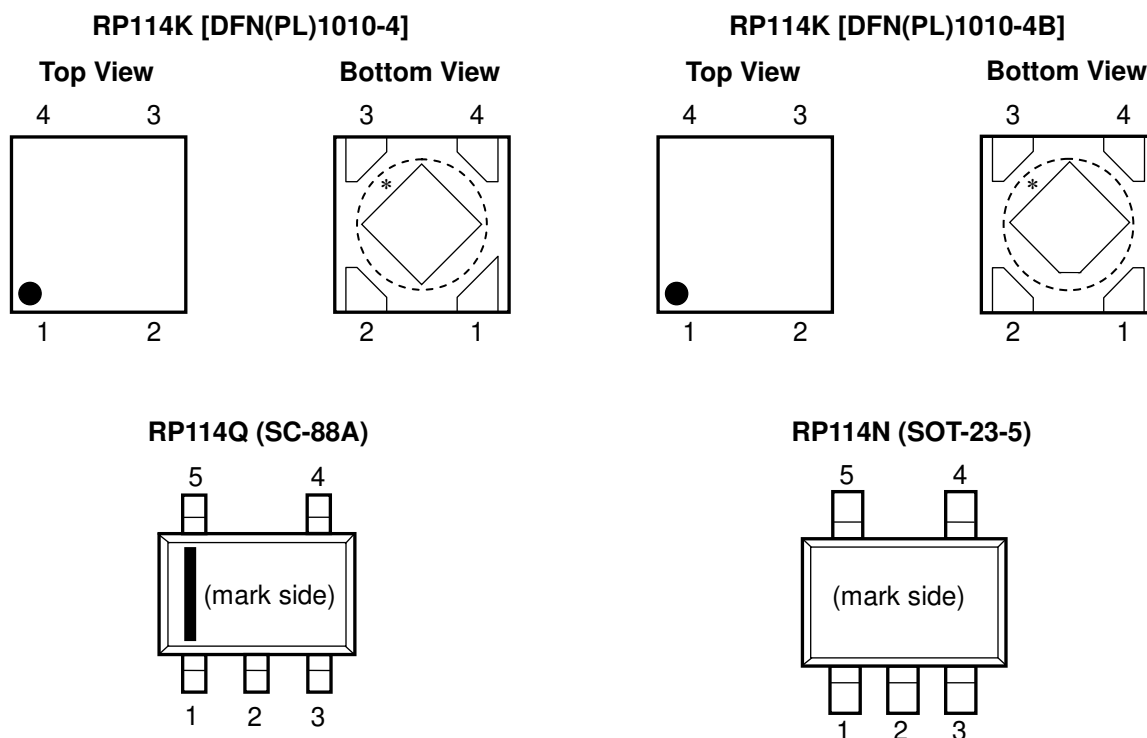

RP114K Pin Description [DFN(PL)1010-4 / DFN(PL)1010-4B]

Pin No	Symbol	Pin Description
1	VOUT	Output Pin
2	GND	Ground Pin
3	CE	Chip Enable Pin ("H" Active)
4	VDD	Input Pin

* Tab is GND level. (They are connected to the reverse side of this IC.) The tab is better to be connected to the GND, but leaving it open is also acceptable.

RP114Q Pin Description (SC-88A)

Pin No	Symbol	Description
1	CE	Chip Enable Pin ("H" Active)
2	NC	No Connection
3	GND	Ground Pin
4	VOUT	Output Pin
5	VDD	Input Pin

RP114N Pin Description (SOT-23-5)

Pin No	Symbol	Description
1	VDD	Input Pin
2	GND	Ground Pin
3	CE	Chip Enable Pin ("H" Active)
4	NC	No Connection
5	VOUT	Output Pin

ABSOLUTE MAXIMUM RATINGS

Symbol	Item	Rating	Unit	
V _{IN}	Input Voltage	6.0	V	
V _{CE}	Input Voltage (CE Pin)	6.0	V	
V _{OUT}	Output Voltage	-0.3 to V _{IN} +0.3	V	
I _{OUT}	Output Current	400	mA	
P _D	Power Dissipation ⁽¹⁾	DFN(PL)1010-4, JEDEC STD. 51	800	mW
		DFN(PL)1010-4B, JEDEC STD. 51	800	
		SC-88A, Our Evaluation Board	380	
		SOT-23-5, JEDEC STD. 51	660	
T _j	Junction Temperature Range	-40 to 125	°C	
T _{stg}	Storage Temperature Range	-55 to 125	°C	

ABSOLUTE MAXIMUM RATINGS

Electronic and mechanical stress momentarily exceeded absolute maximum ratings may cause the permanent damages and may degrade the life time and safety for both device and system using the device in the field. The functional operation at or over these absolute maximum ratings are not assured.

RECOMMENDED OPERATING CONDITIONS

Symbol	Item	Rating	Unit
V _{IN}	Input Voltage	1.4 to 5.25 ⁽²⁾	V
T _a	Operating Temperature Range	-40 to 85	°C

RECOMMENDED OPERATING CONDITIONS

All of electronic equipment should be designed that the mounted semiconductor devices operate within the recommended operating conditions. The semiconductor devices cannot operate normally over the recommended operating conditions, even if when they are used over such ratings by momentary electronic noise or surge. And the semiconductor devices may receive serious damage when they continue to operate over the recommended operating conditions.

⁽¹⁾ Refer to *POWER DISSIPATION* for detailed information.

⁽²⁾ If the input voltage exceeds the maximum value of 5.25 V for some reasons, the operational accumulated time becomes up to 500 hours at 5.5V.

ELECTRICAL CHARACTERISTICS

$V_{IN} = V_{SET}^{(1)} + 1.0 \text{ V}$ ($V_{SET} > 1.5 \text{ V}$), $V_{IN} = 2.5 \text{ V}$ ($V_{SET} \leq 1.5 \text{ V}$), $I_{OUT} = 1 \text{ mA}$, $C_{IN} = C_{OUT} = 1.0 \mu\text{F}$, unless otherwise noted.

The specifications in are guaranteed by design engineering at $-40^\circ\text{C} \leq T_a \leq 85^\circ\text{C}$.

RP114xxxxB/D Electrical Characteristics

($T_a = 25^\circ\text{C}$)

Symbol	Item	Conditions	Min.	Typ.	Max.	Unit	
V_{OUT}	Output Voltage	$T_a = 25^\circ\text{C}$	$V_{SET} > 2.0 \text{ V}$	$\times 0.99$		$\times 1.01$	V
			$V_{SET} \leq 2.0 \text{ V}$	-20		+20	mV
		$-40^\circ\text{C} \leq T_a \leq 85^\circ\text{C}$	$V_{SET} > 2.0 \text{ V}$	$\times 0.97$		$\times 1.03$	V
			$V_{SET} \leq 2.0 \text{ V}$	-60		+60	mV
I_{OUT}	Output Current		300			mA	
$\Delta V_{OUT}/\Delta I_{OUT}$	Load Regulation	$1 \text{ mA} \leq I_{OUT} \leq 300 \text{ mA}$		15	40	mV	
V_{DIF}	Dropout Voltage	Please refer to <i>Product-specific Electrical Characteristics</i> attached.					
I_{SS}	Supply Current	$I_{OUT} = 0 \text{ mA}$		50	75	μA	
$I_{standby}$	Standby Current	$V_{CE} = 0 \text{ V}$		0.1	1.0	μA	
$\frac{\Delta V_{OUT}}{\Delta V_{IN}}$	Line Regulation	$V_{SET} + 0.5 \text{ V} \leq V_{IN} \leq 5.25 \text{ V}$ ($V_{IN} \geq 1.4 \text{ V}$)		0.02	0.10	%/V	
R_R	Ripple Rejection	$f = 1 \text{ kHz}$, Ripple 0.2 V_{p-p} , $V_{IN} = V_{SET} + 1 \text{ V}$, $I_{OUT} = 30 \text{ mA}$ (When $V_{SET} \leq 2.0 \text{ V}$, $V_{IN} = 3.0 \text{ V}$)		75		dB	
$\Delta V_{OUT}/\Delta T_a$	Output Voltage Temperature Coefficient	$-40^\circ\text{C} \leq T_a \leq 85^\circ\text{C}$		± 80		ppm/ $^\circ\text{C}$	
I_{SC}	Short Current Limit	$V_{OUT} = 0 \text{ V}$		60		mA	
I_{PD}	CE Pull-down Current			0.3	0.6	μA	
V_{CEH}	CE Input Voltage "H"		1.0			V	
V_{CEL}	CE Input Voltage "L"				0.4	V	
e_n	Output Noise	$\text{BW} = 10 \text{ Hz to } 100 \text{ kHz}$, $I_{OUT} = 30 \text{ mA}$		75		μV_{rms}	
R_{LOW}	Low Output Nch. On Resistance (RP114xxxxD Only)	$V_{IN} = 4.0 \text{ V}$, $V_{CE} = 0 \text{ V}$		50		Ω	

All test items listed under Electrical Characteristics are done under the pulse load condition ($T_j \approx T_a = 25^\circ\text{C}$) except for Output Noise, Ripple Rejection, and Output Voltage Temperature Coefficient.

⁽¹⁾ V_{SET} : Set Output Voltage

The specifications in are guaranteed by design engineering at $-40^{\circ}\text{C} \leq T_a \leq 85^{\circ}\text{C}$.

Dropout Voltage by Set Output Voltage

(Ta=25°C)

Set Output Voltage V_{SET} (V)	Dropout Voltage V_{DIF} (V)		
	Condition	Typ.	Max.
$V_{\text{SET}}=0.8$	$I_{\text{OUT}}=300\text{mA}$	0.560	<input type="text" value="0.720"/>
$V_{\text{SET}}=0.9$		0.510	<input type="text" value="0.650"/>
$1.0 \leq V_{\text{SET}} < 1.2$		0.460	<input type="text" value="0.590"/>
$1.2 \leq V_{\text{SET}} < 1.4$		0.390	<input type="text" value="0.500"/>
$1.4 \leq V_{\text{SET}} < 1.7$		0.350	<input type="text" value="0.440"/>
$1.7 \leq V_{\text{SET}} < 2.1$		0.300	<input type="text" value="0.390"/>
$2.1 \leq V_{\text{SET}} < 2.5$		0.260	<input type="text" value="0.340"/>
$2.5 \leq V_{\text{SET}} < 3.0$		0.250	<input type="text" value="0.300"/>
$3.0 \leq V_{\text{SET}} \leq 3.6$		0.220	<input type="text" value="0.290"/>

Product-specific Electrical Characteristics

The specifications in are guaranteed by design engineering at $-40^{\circ}\text{C} \leq T_a \leq 85^{\circ}\text{C}$.

Product Name	V _{OUT} [V] (Ta = 25°C)			V _{OUT} [V] (-40°C ≤ Ta ≤ 85°C)			V _{DIF} [V]	
	Min.	Typ.	Max.	Min.	Typ.	Max.	Typ.	Max.
RP114x081x	0.780	0.800	0.820	0.740	0.800	0.860	0.560	0.720
RP114x091x	0.880	0.900	0.920	0.840	0.900	0.960	0.510	0.650
RP114x101x	0.980	1.000	1.020	0.940	1.000	1.060	0.460	0.590
RP114x101x5	1.030	1.050	1.070	0.990	1.050	1.110		
RP114x111x	1.080	1.100	1.120	1.040	1.100	1.160		
RP114x111x5	1.130	1.150	1.170	1.090	1.150	1.210		
RP114x121x	1.180	1.200	1.220	1.140	1.200	1.260		
RP114x121x5	1.230	1.250	1.270	1.190	1.250	1.310	0.390	0.500
RP114x131x	1.280	1.300	1.320	1.240	1.300	1.360		
RP114x131x5	1.330	1.350	1.370	1.290	1.350	1.410		
RP114x141x	1.380	1.400	1.420	1.340	1.400	1.460	0.350	0.440
RP114x151x	1.480	1.500	1.520	1.440	1.500	1.560		
RP114x161x	1.580	1.600	1.620	1.540	1.600	1.660		
RP114x171x	1.680	1.700	1.720	1.640	1.700	1.760	0.300	0.390
RP114x171x5	1.730	1.750	1.770	1.690	1.750	1.810		
RP114x181x	1.780	1.800	1.820	1.740	1.800	1.860		
RP114x181x5	1.830	1.850	1.870	1.790	1.850	1.910		
RP114x191x	1.880	1.900	1.920	1.840	1.900	1.960		
RP114x201x	1.980	2.000	2.020	1.940	2.000	2.060	0.260	0.340
RP114x211x	2.079	2.100	2.121	2.037	2.100	2.163		
RP114x221x	2.178	2.200	2.222	2.134	2.200	2.266		
RP114x231x	2.277	2.300	2.323	2.231	2.300	2.369		
RP114x241x	2.376	2.400	2.424	2.328	2.400	2.472		
RP114x251x	2.475	2.500	2.525	2.425	2.500	2.575	0.250	0.300
RP114x261x	2.574	2.600	2.626	2.522	2.600	2.678		
RP114x271x	2.673	2.700	2.727	2.619	2.700	2.781		
RP114x281x	2.772	2.800	2.828	2.716	2.800	2.884		
RP114x281x5	2.822	2.850	2.879	2.765	2.850	2.936		
RP114x291x	2.871	2.900	2.929	2.813	2.900	2.987		
RP114x301x	2.970	3.000	3.030	2.910	3.000	3.090		
RP114x311x	3.069	3.100	3.131	3.007	3.100	3.193	0.220	0.290
RP114x321x	3.168	3.200	3.232	3.104	3.200	3.296		
RP114x331x	3.267	3.300	3.333	3.201	3.300	3.399		
RP114x341x	3.366	3.400	3.434	3.298	3.400	3.502		
RP114x341x5	3.416	3.450	3.485	3.347	3.450	3.554		
RP114x351x	3.465	3.500	3.535	3.395	3.500	3.605		
RP114x361x	3.564	3.600	3.636	3.492	3.600	3.708		

TEST CIRCUITS

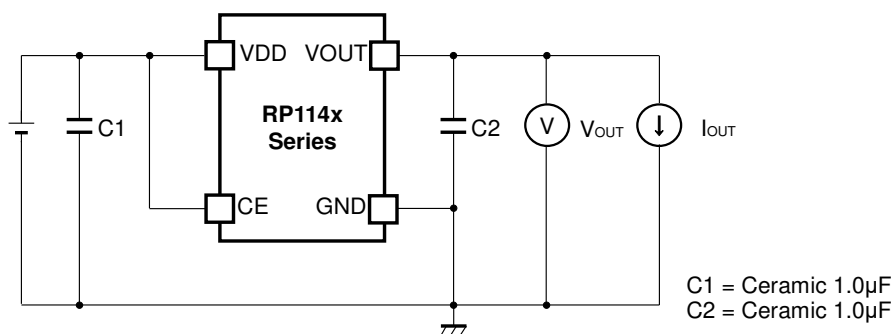

Figure 1. Basic Test Circuit

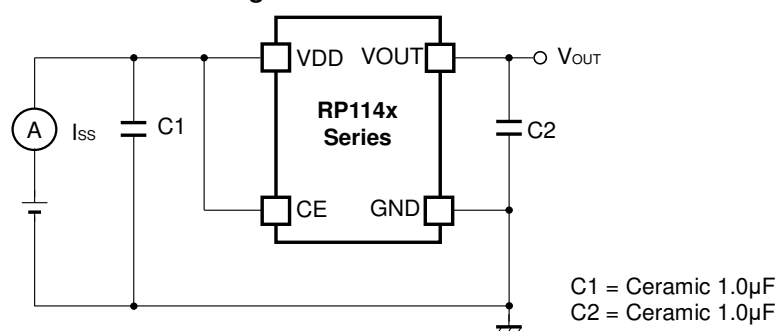

Figure 2. Test Circuit for Supply Current

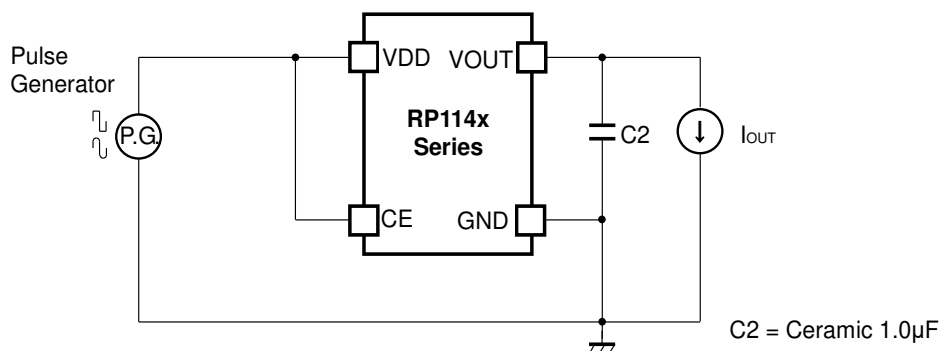

Figure 3. Test Circuit for Ripple Rejection

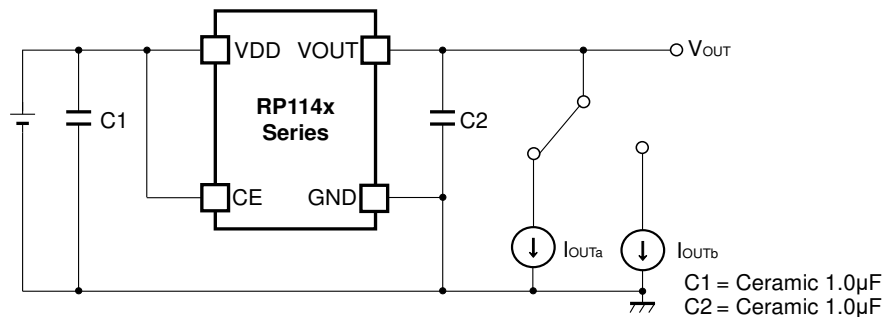

Figure 4. Test Circuit for Load Transient Response

TECHNICAL NOTES ON EXTERNAL COMPONENTS

When using these ICs, consider the following points:

Phase Compensation

In this IC, phase compensation is made for securing stable operation even if the load current is varied. For this purpose, use a capacitor C2 with 1.0 μ F or more and good ESR (Equivalent Series Resistance).

(Note: If additional ceramic capacitors are connected with parallel to the output pin with an output capacitor for phase compensation, the operation might be unstable. Because of this, test this IC with as same external components as ones to be used on the PCB.)

PCB Layout

Make V_{DD} and GND lines sufficient. If their impedance is high, noise pickup or unstable operation may result. Connect a capacitor C1 with a capacitance value as much as 1.0 μ F or more between V_{DD} and GND pins, and as close as possible to the pins.

Set external components, especially the output capacitor C2, as close as possible to the IC, and make wiring as short as possible.

Typical Application Circuit

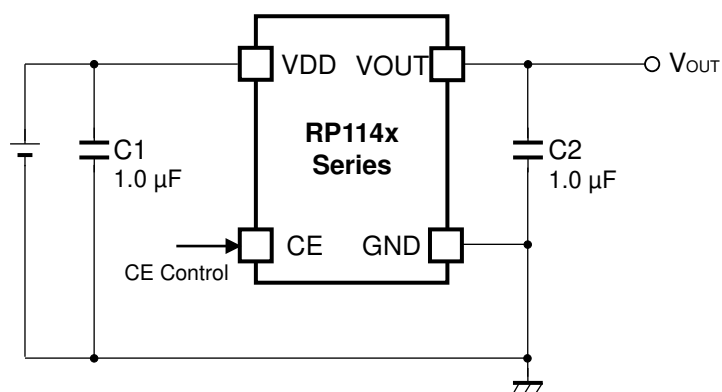

ESR vs. Output Current

When using these ICs, consider the following points:

The relations between I_{OUT} (Output Current) and ESR of an output capacitor are shown below. The conditions when the white noise level is under $40\mu V$ (Avg.) are marked as the hatched area in the graph.

Measurement conditions

Frequency Band: 10Hz to 2MHz

Temperature : $-40^{\circ}C$ to $85^{\circ}C$

C1, C2 : $1.0\mu F$

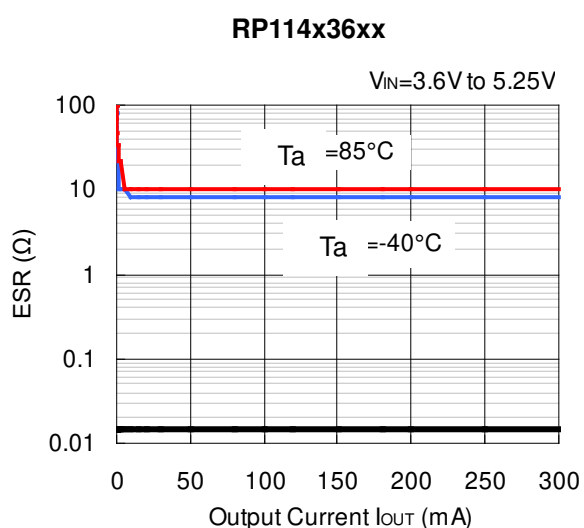
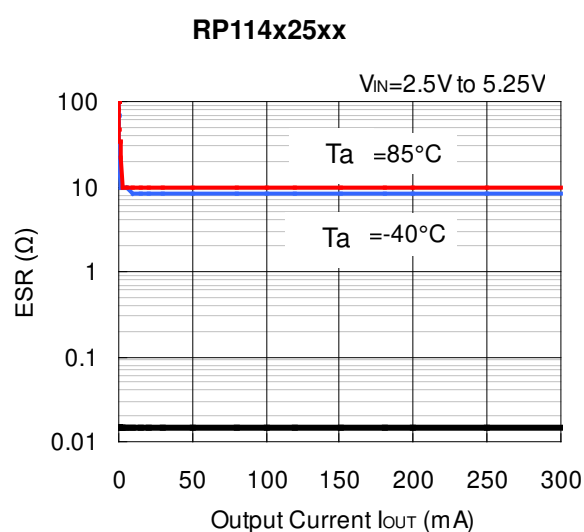
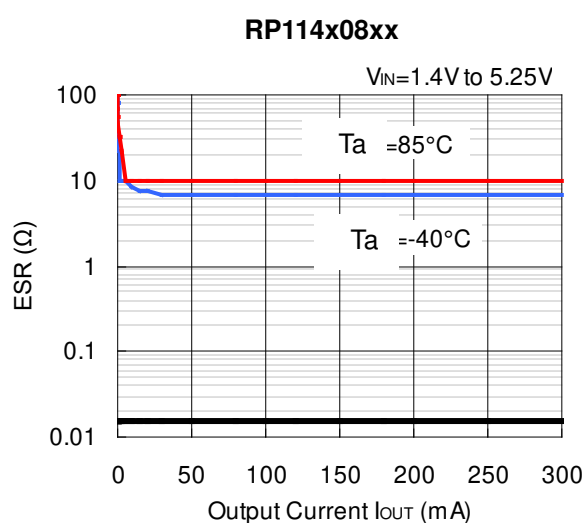

TYPICAL CHARACTERISTICS

Note: Typical Characteristics are intended to be used as reference data; they are not guaranteed.

1) Output Voltage vs. Output Current (C1=1.0μF, C2=1.0μF, Ta=25°C)

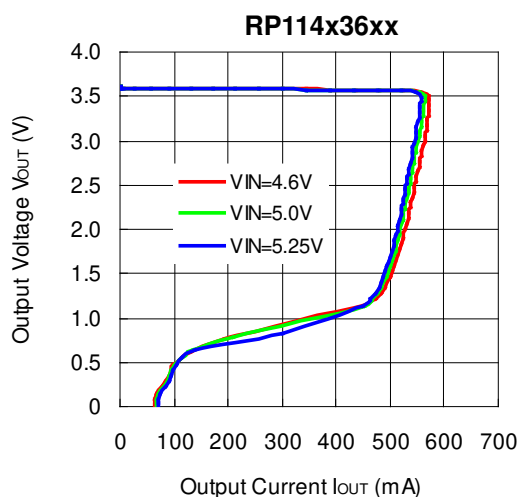
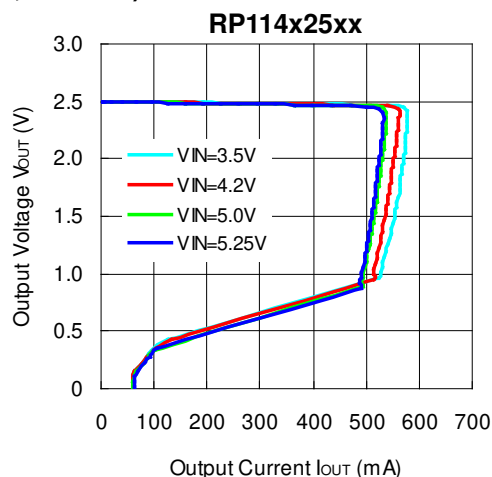
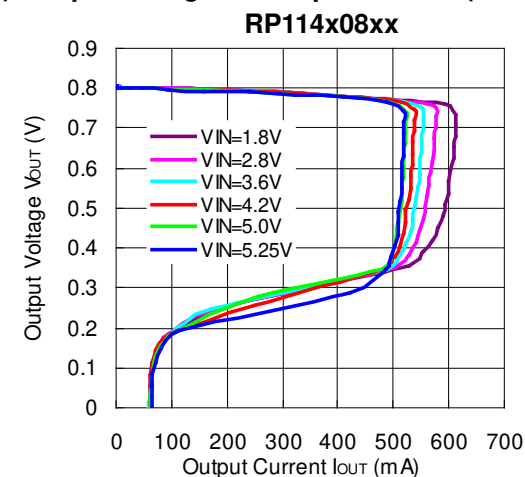

2) Output Voltage vs. Input Voltage (C1=1.0μF, C2=1.0μF, Ta=25°C)

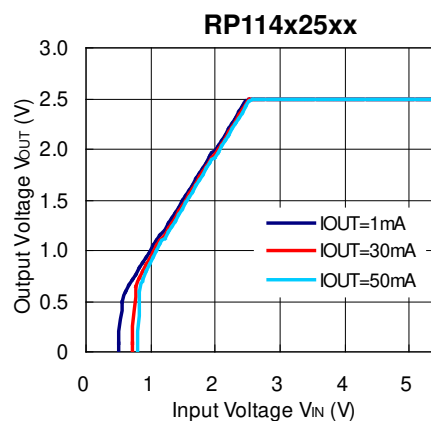
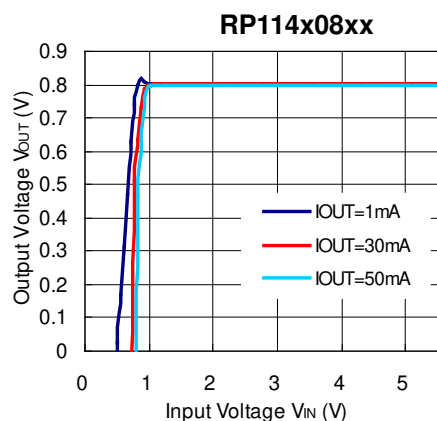

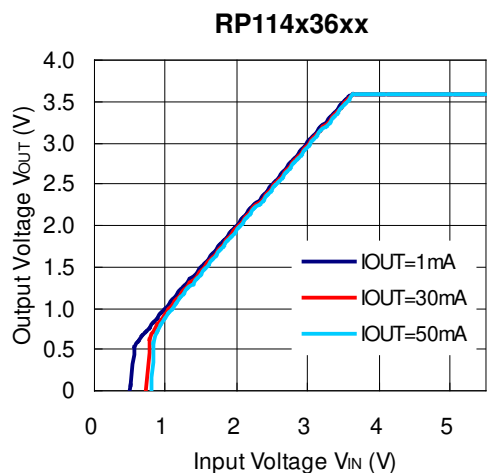

3) Supply Current vs. Input Voltage ($C1=1.0\mu F$, $C2=1.0\mu F$, $T_a=25^\circ C$)

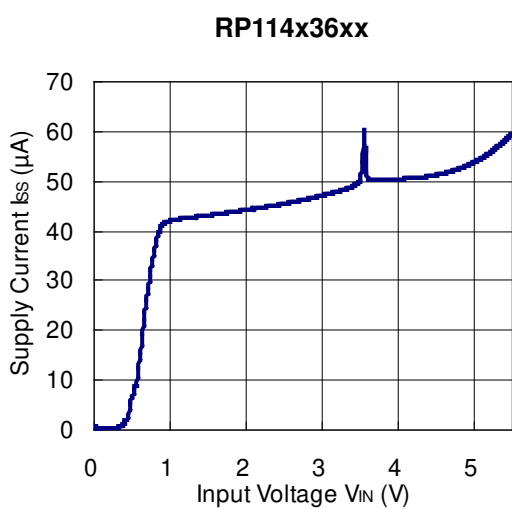
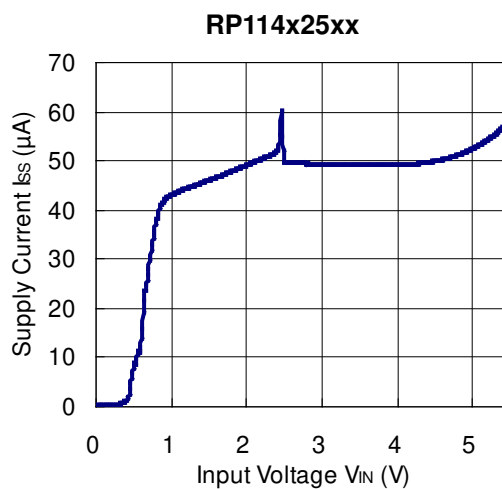
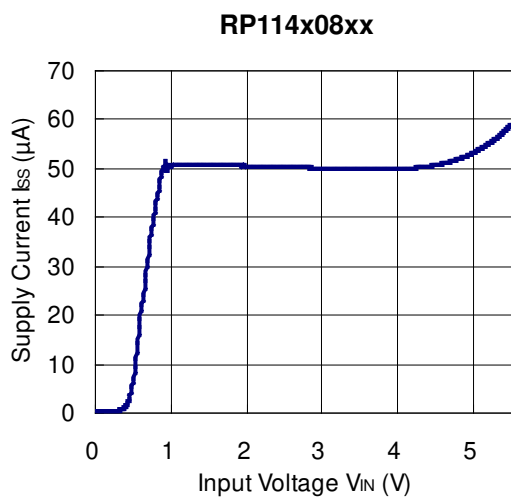

4) Output Voltage vs. Temperature (C1=1.0μF, C2=1.0μF, I_{OUT}=1mA)

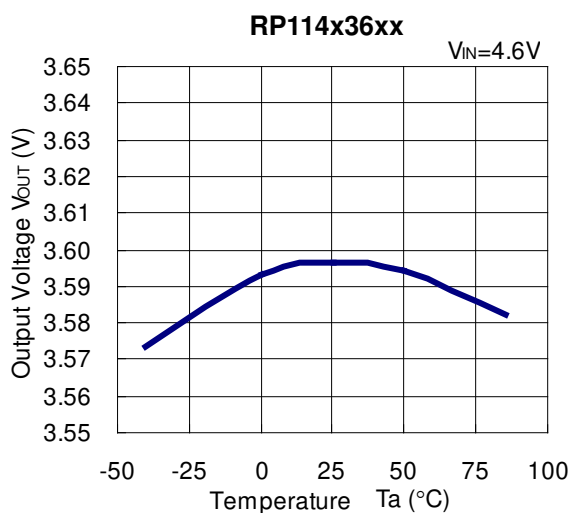
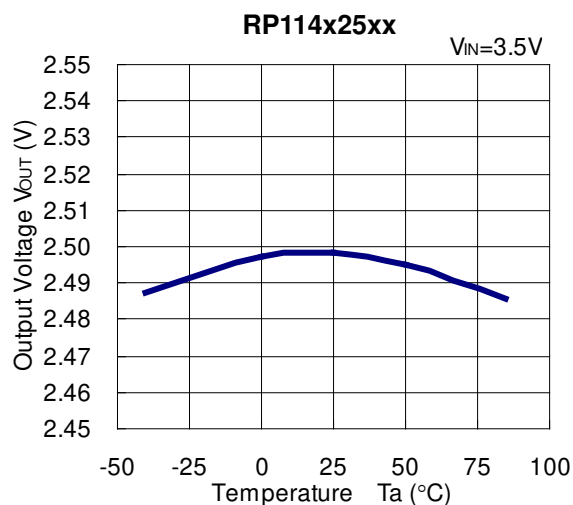
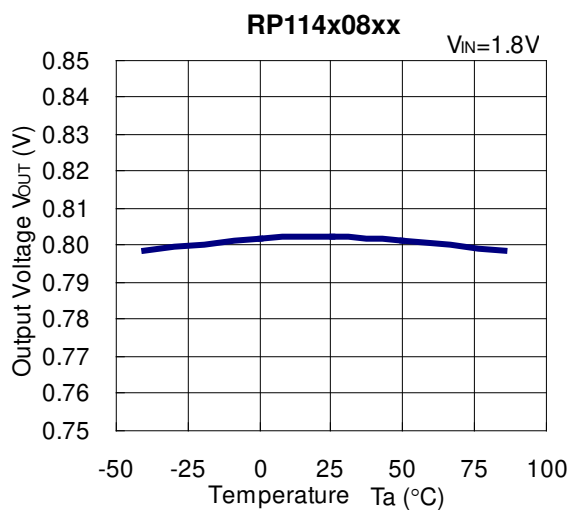

5) Supply Current vs. Temperature (C1=1.0μF, C2=1.0μF, I_{OUT}=0mA)

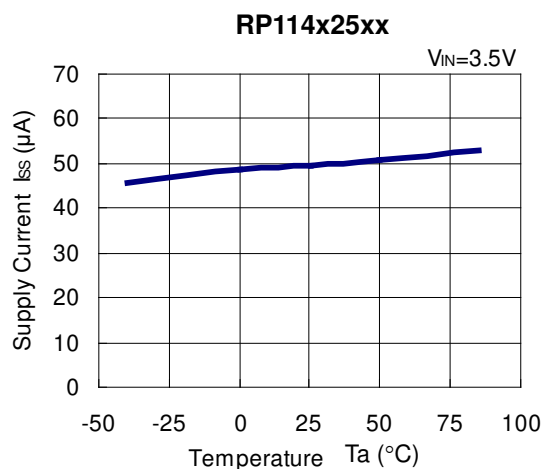
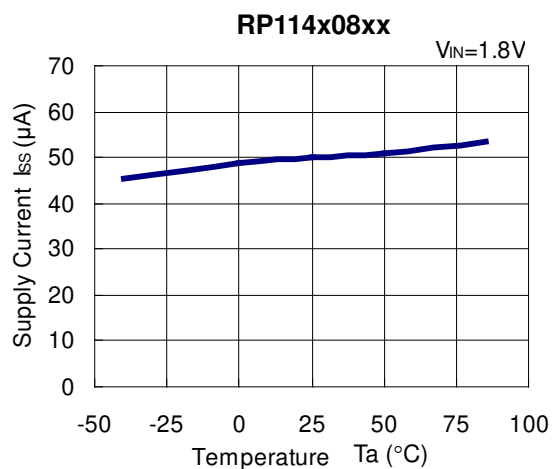

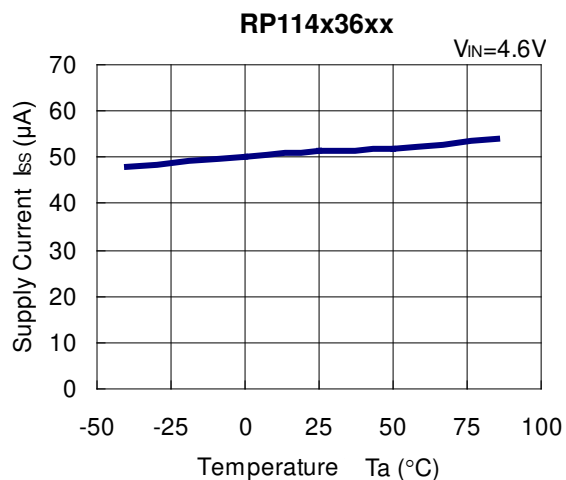

6) Dropout Voltage vs. Output Current ($C1=1.0\mu F$, $C2=1.0\mu F$)

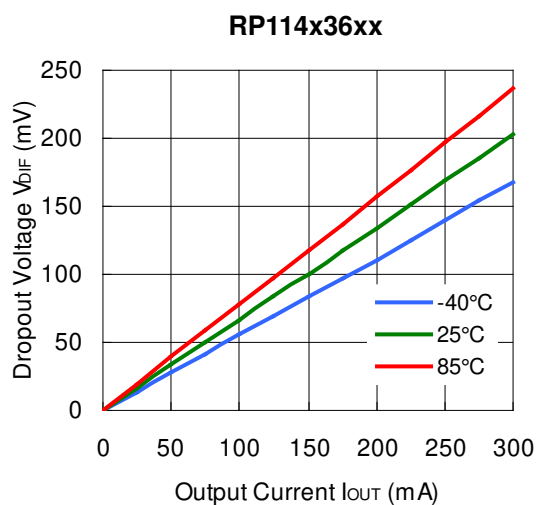
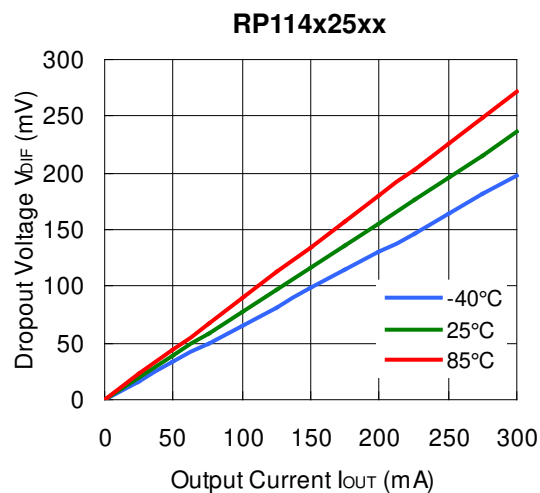
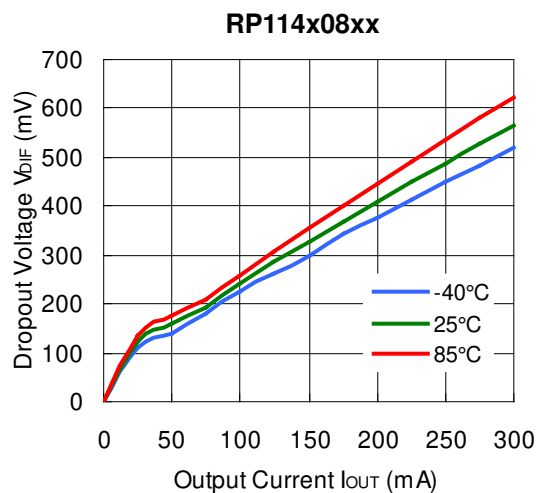

7) Dropout Voltage vs. Set Output Voltage (C1=1.0μF, C2=1.0μF, Ta=25°C)

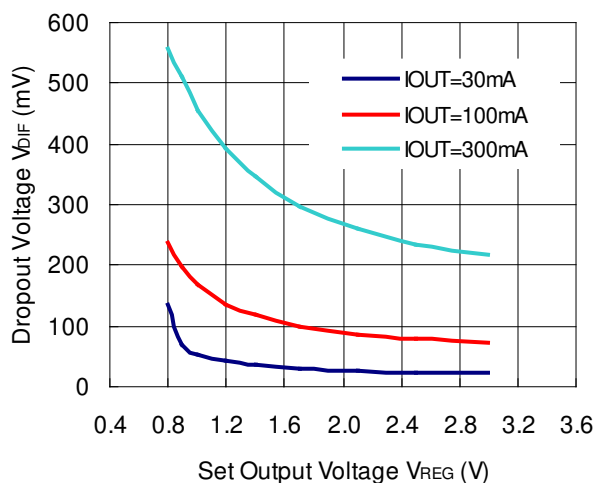

8) Dropout Voltage vs. Temperature (C1=none, C2=1.0μF)

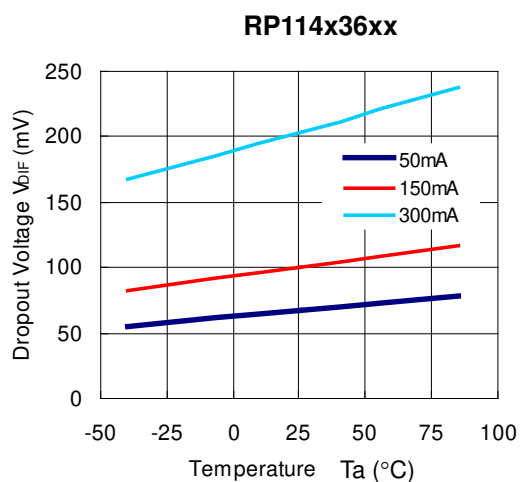
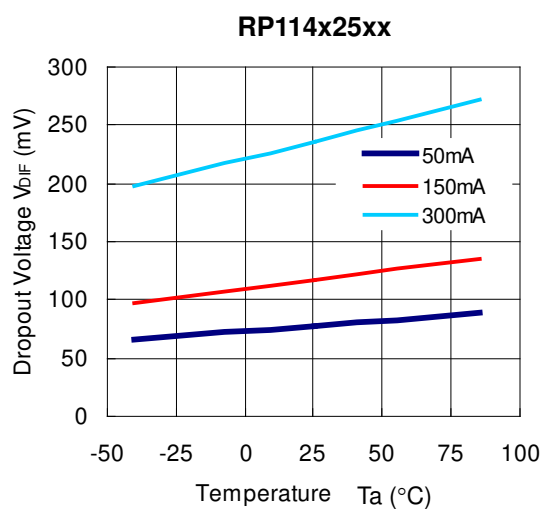
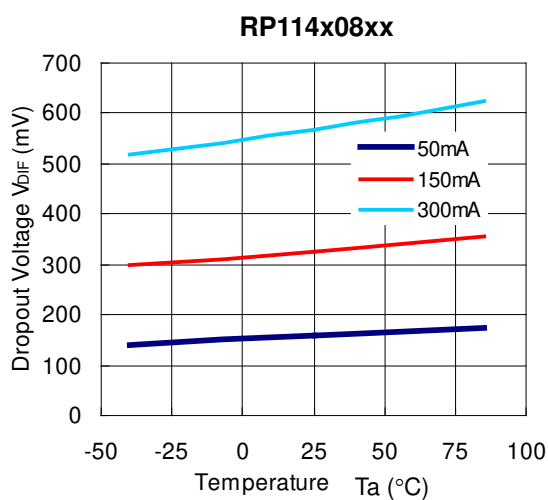

9) Ripple Rejection vs. Input Voltage (C1=none, C2=1.0μF, Ripple=0.2Vp-p, Ta=25°C)

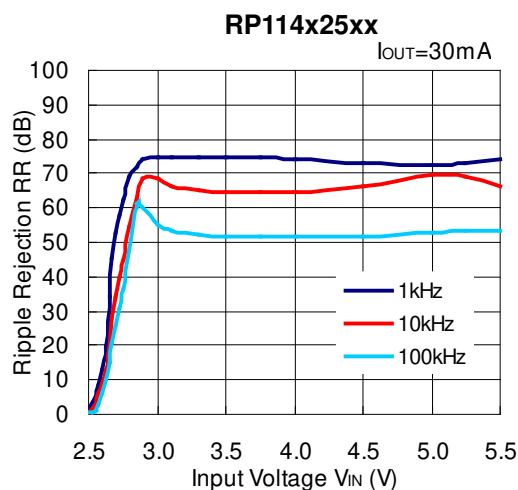
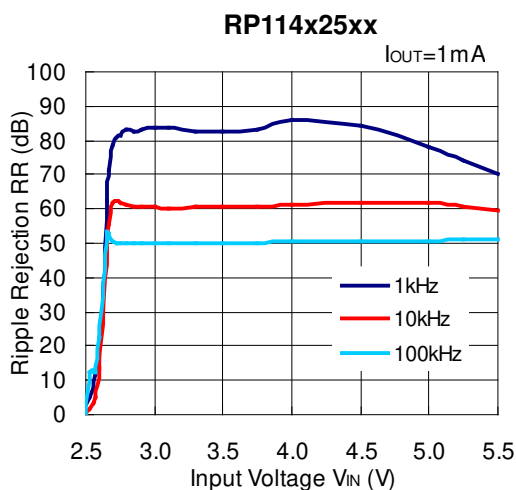

10) Ripple Rejection vs. Frequency (C1=none, C2=1.0μF, Ta=25°C)

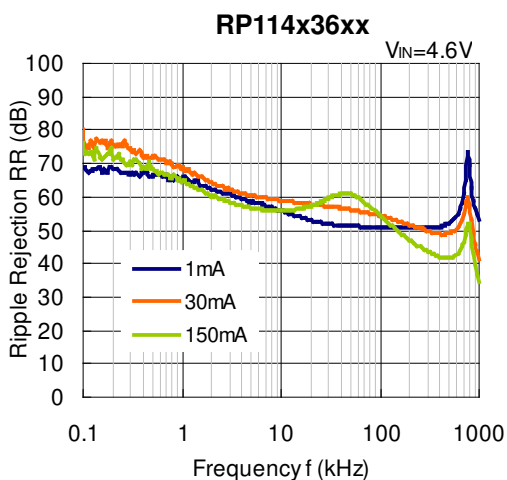
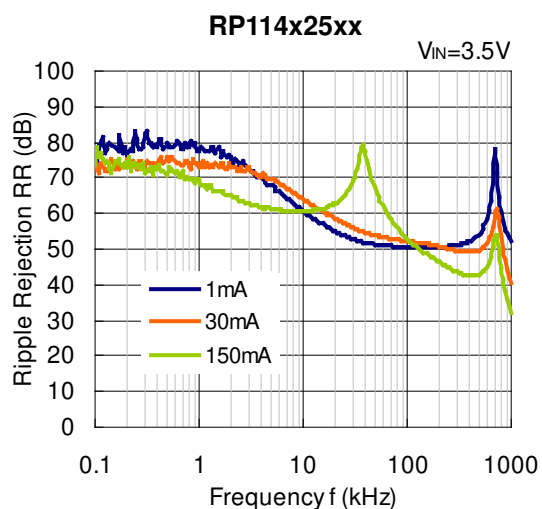
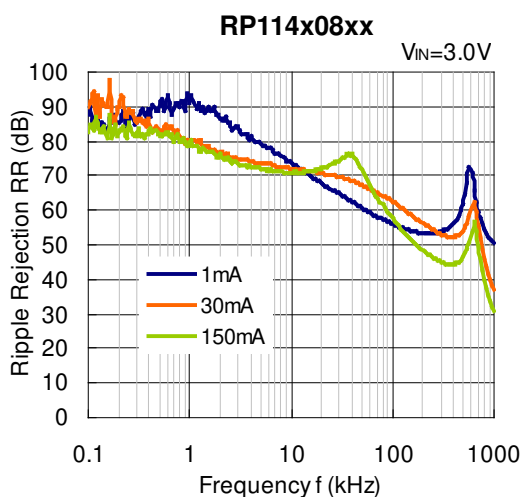

11) Input Transient Response ($I_{OUT}=30mA$, $t_r=t_f=5\mu s$, $T_a=25^\circ C$)

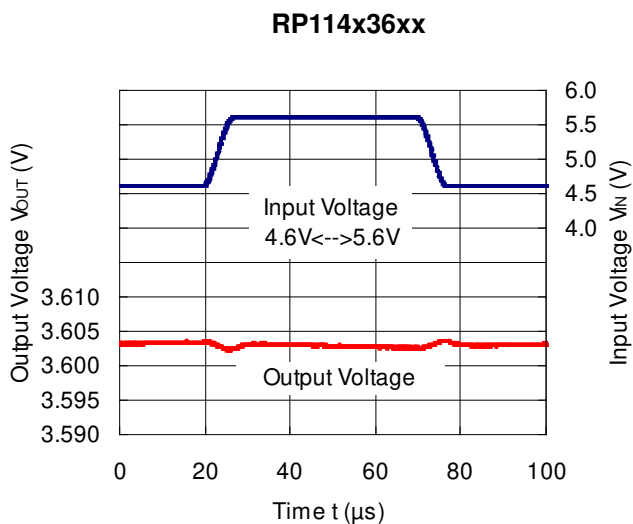
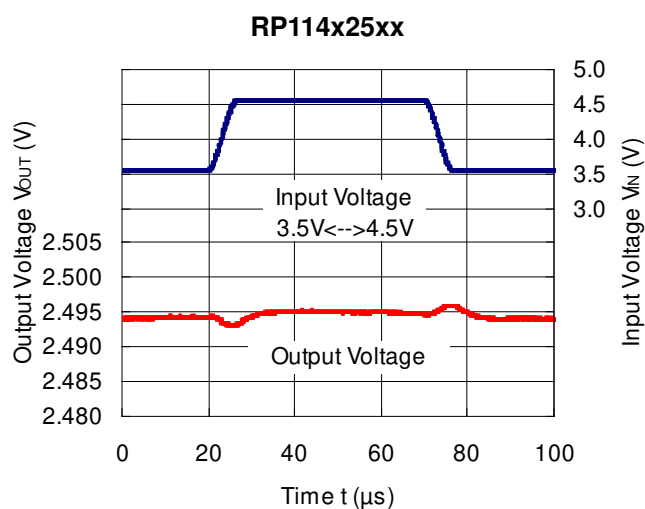
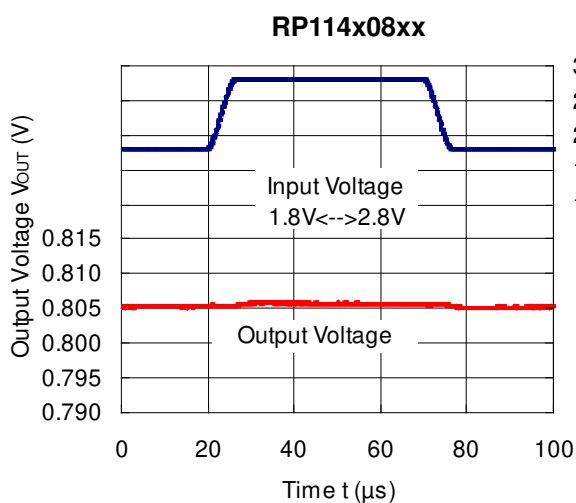

12) Load Transient Response ($C_1=1.0\mu F$, $C_2=1.0\mu F$, $t_r=t_f=0.5\mu s$, $T_a=25^\circ C$)

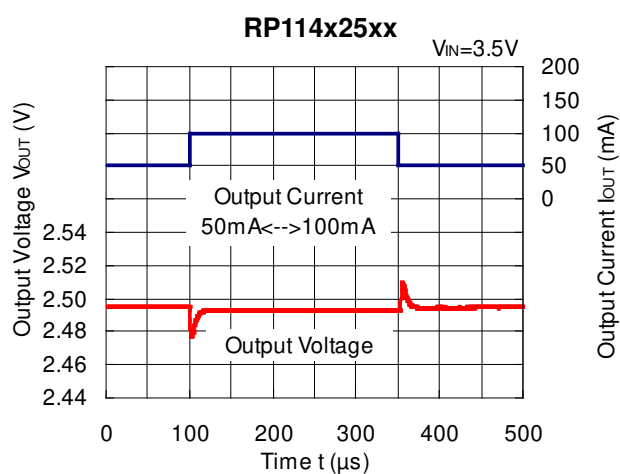
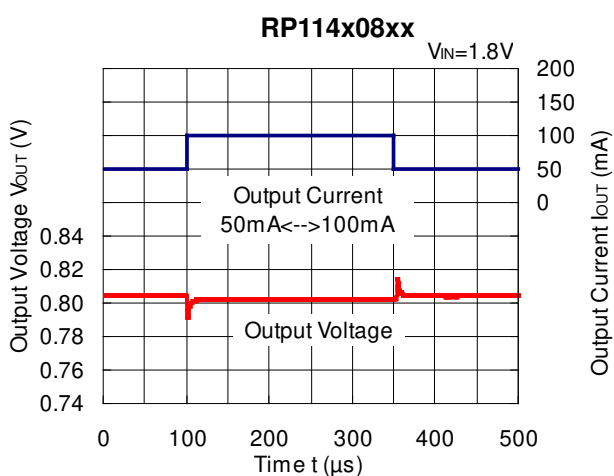

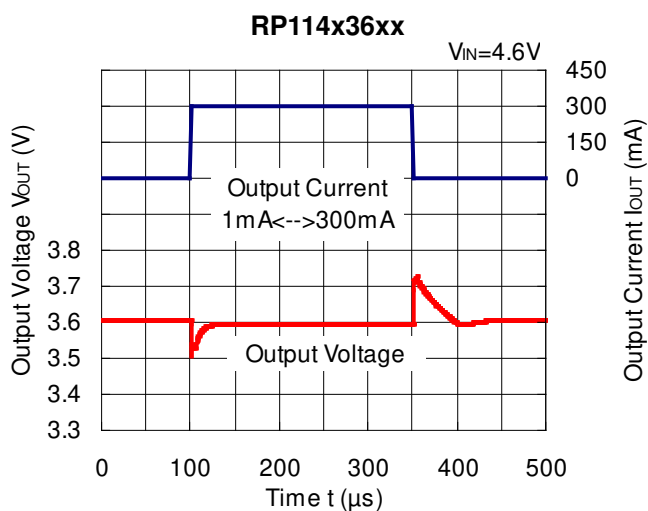
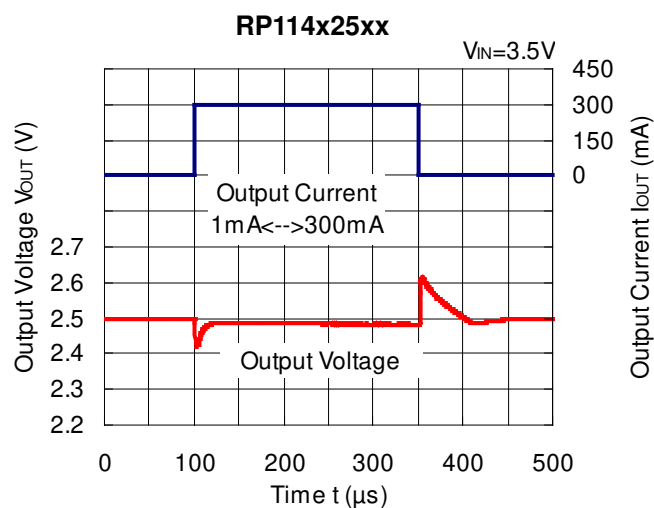
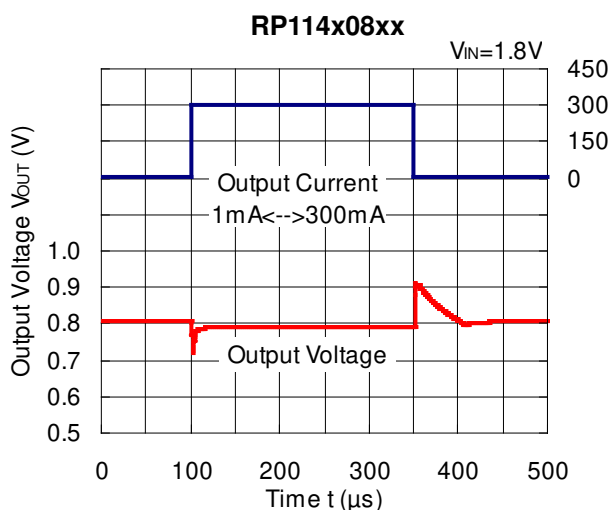
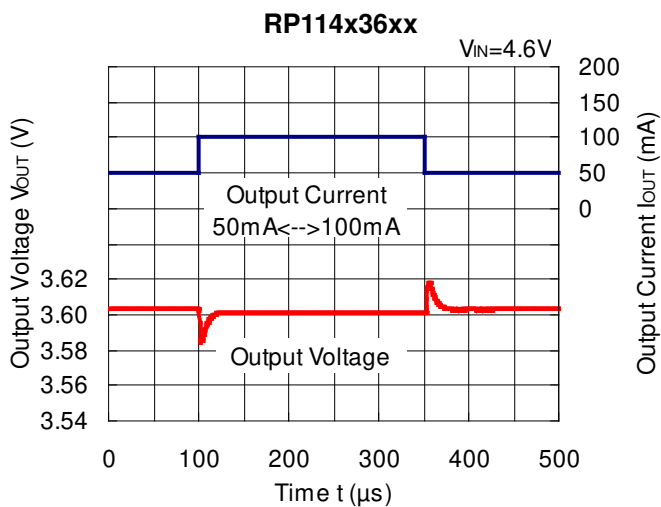

13) Turn On Speed with CE pin (C1=1.0μF, C2=1.0μF, Ta=25°C)

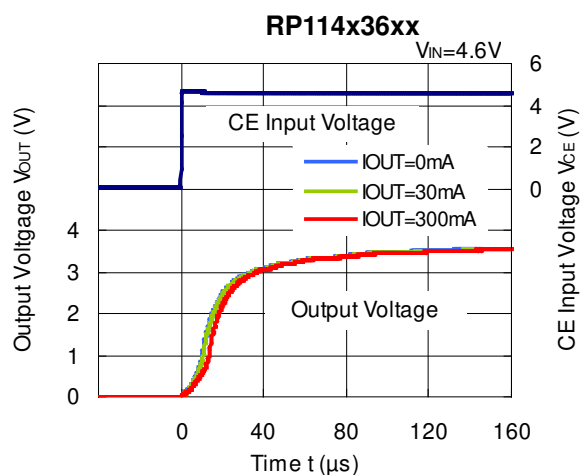
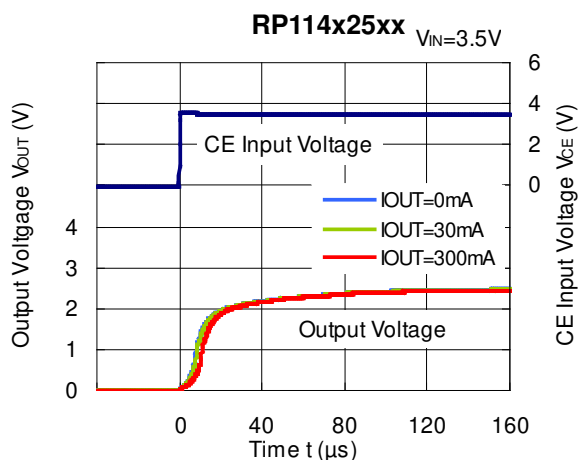
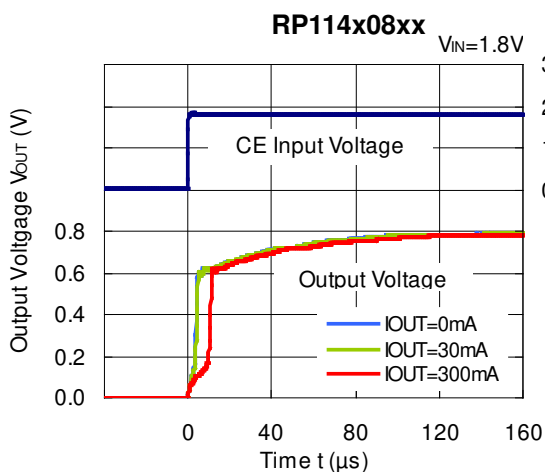

14) Turn Off Speed with CE pin (B version) (C1=1.0μF, C2=1.0μF, Ta=25°C)

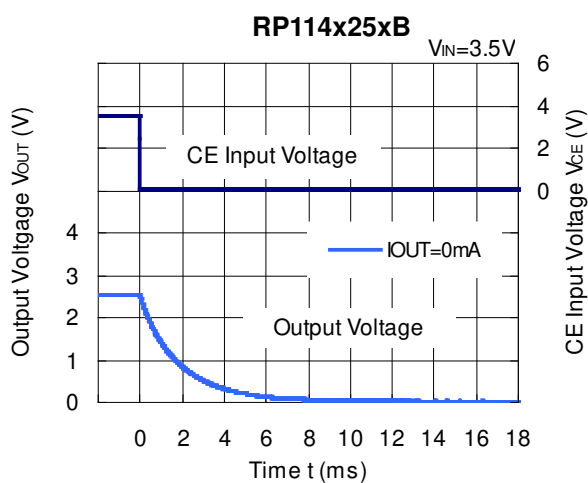
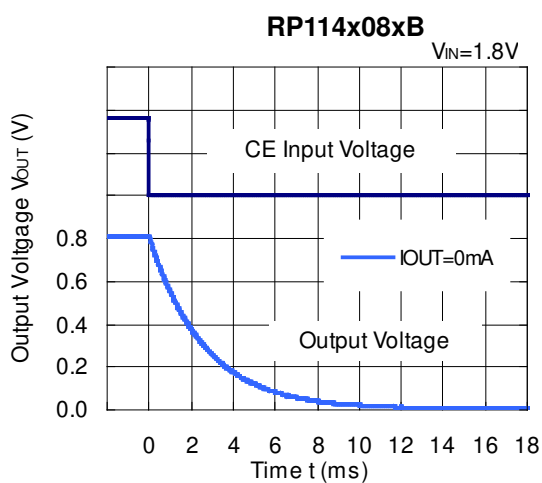

RP114x36xB

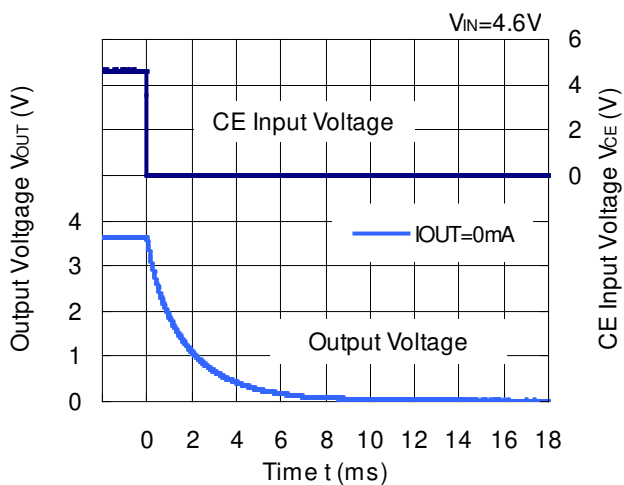

15) Turn Off Speed with CE pin (D version) (C1=1.0μF, C2=1.0μF, Ta=25°C)

RP114x08xD

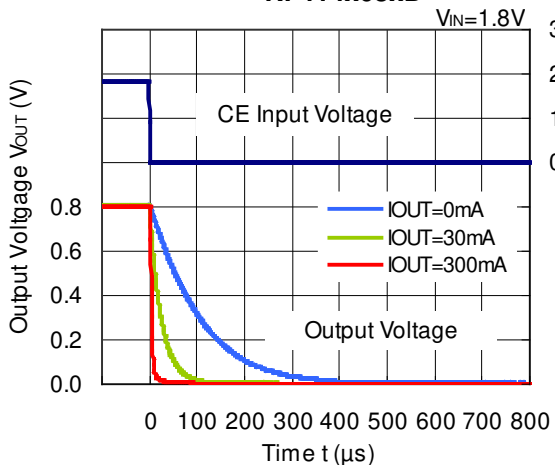

RP114x25xD

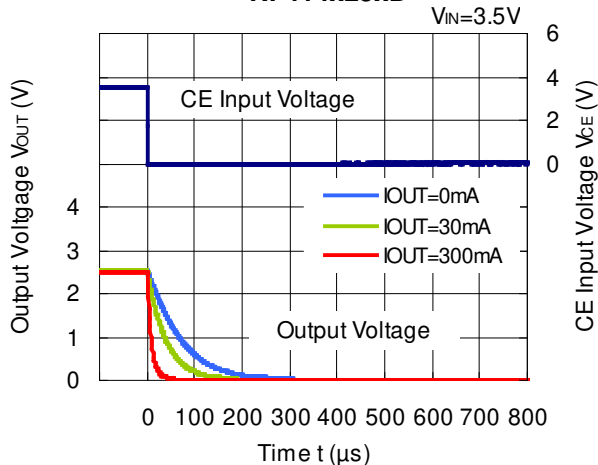

RP114x36xD

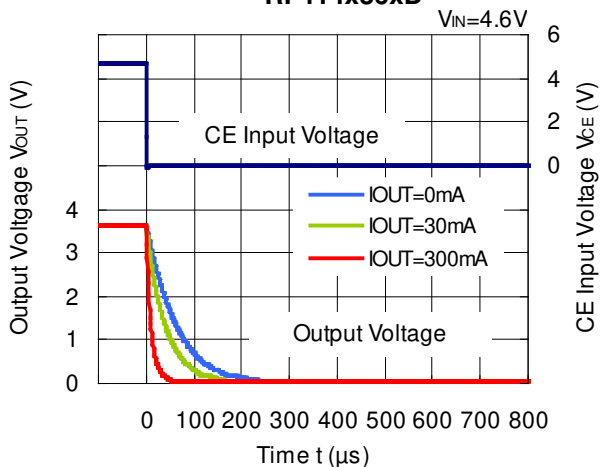

The power dissipation of the package is dependent on PCB material, layout, and environmental conditions. The following measurement conditions are based on JEDEC STD. 51-7.

Measurement Conditions

Item	Measurement Conditions
Environment	Mounting on Board (Wind Velocity = 0 m/s)
Board Material	Glass Cloth Epoxy Plastic (Four-Layer Board)
Board Dimensions	76.2 mm × 114.3 mm × 0.8 mm
Copper Ratio	Outer Layer (First Layer): Less than 95% of 50 mm Square Inner Layers (Second and Third Layers): Approx. 100% of 50 mm Square Outer Layer (Fourth Layer): Approx. 100% of 50 mm Square
Through-holes	φ 0.2 mm × 11 pcs

Measurement Result

(Ta = 25°C, Tjmax = 125°C)

Item	Measurement Result
Power Dissipation	800 mW
Thermal Resistance (θja)	θja = 125°C/W
Thermal Characterization Parameter (ψjt)	ψjt = 58°C/W

θja: Junction-to-Ambient Thermal Resistance

ψjt: Junction-to-Top Thermal Characterization Parameter

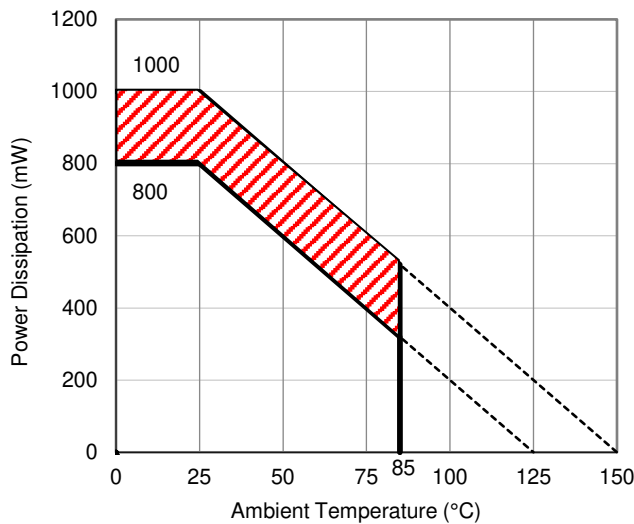

Power Dissipation vs. Ambient Temperature

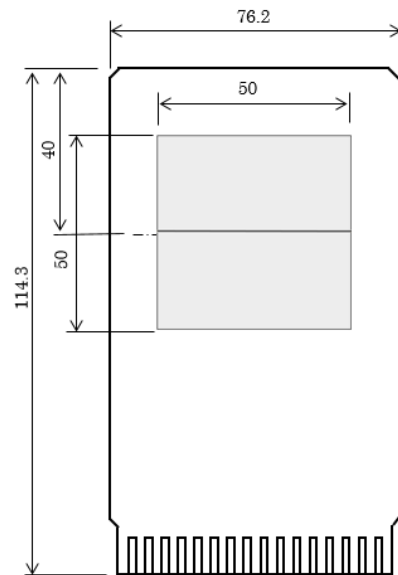

Measurement Board Pattern

The above graph shows the power dissipation of the package at Tjmax = 125°C and Tjmax = 150°C. Operating the device in the hatched range might have a negative influence on its lifetime. The total hours of use and the total years of use must be limited as follows:

Total Hours of Use	Total Years of Use (4 hours/day)
13,000 hours	9 years

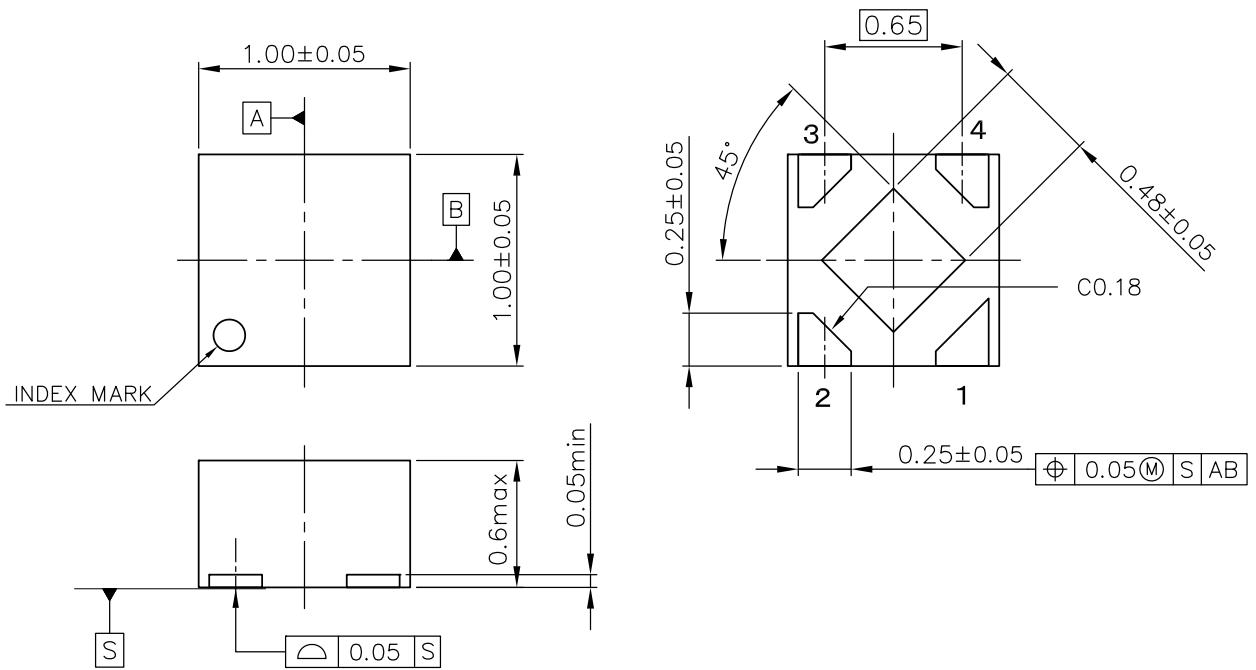

UNIT: mm

DFN(PL)1010-4 Package Dimensions

The power dissipation of the package is dependent on PCB material, layout, and environmental conditions. The following measurement conditions are based on JEDEC STD. 51-7.

Measurement Conditions

Item	Measurement Conditions
Environment	Mounting on Board (Wind Velocity = 0 m/s)
Board Material	Glass Cloth Epoxy Plastic (Four-Layer Board)
Board Dimensions	76.2 mm × 114.3 mm × 0.8 mm
Copper Ratio	Outer Layer (First Layer): Less than 95% of 50 mm Square Inner Layers (Second and Third Layers): Approx. 100% of 50 mm Square Outer Layer (Fourth Layer): Approx. 100% of 50 mm Square
Through-holes	φ 0.2 mm × 11 pcs

Measurement Result (Ta = 25°C, Tjmax = 125°C)

Item	Measurement Result
Power Dissipation	800 mW
Thermal Resistance (θ_{ja})	$\theta_{ja} = 125^\circ\text{C/W}$
Thermal Characterization Parameter (ψ_{jt})	$\psi_{jt} = 58^\circ\text{C/W}$

θ_{ja} : Junction-to-Ambient Thermal Resistance

ψ_{jt} : Junction-to-Top Thermal Characterization Parameter

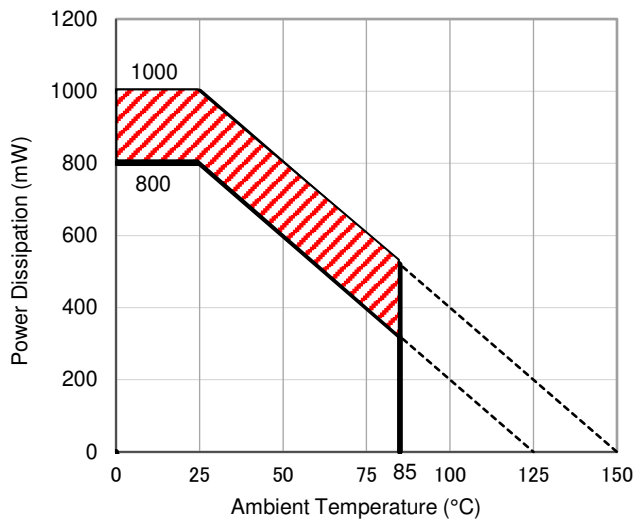

Power Dissipation vs. Ambient Temperature

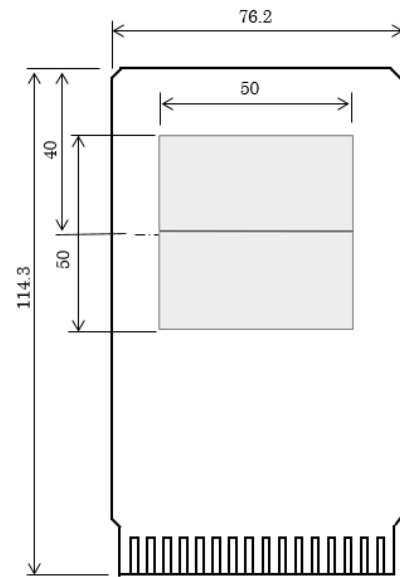

Measurement Board Pattern

The above graph shows the power dissipation of the package at $T_{jmax} = 125^\circ\text{C}$ and $T_{jmax} = 150^\circ\text{C}$. Operating the device in the hatched range might have a negative influence on its lifetime. The total hours of use and the total years of use must be limited as follows:

Total Hours of Use	Total Years of Use (4 hours/day)
13,000 hours	9 years

PACKAGE DIMENSIONS

DFN(PL)1010-4B

DM-DFN(PL)1010-4B-JE-B

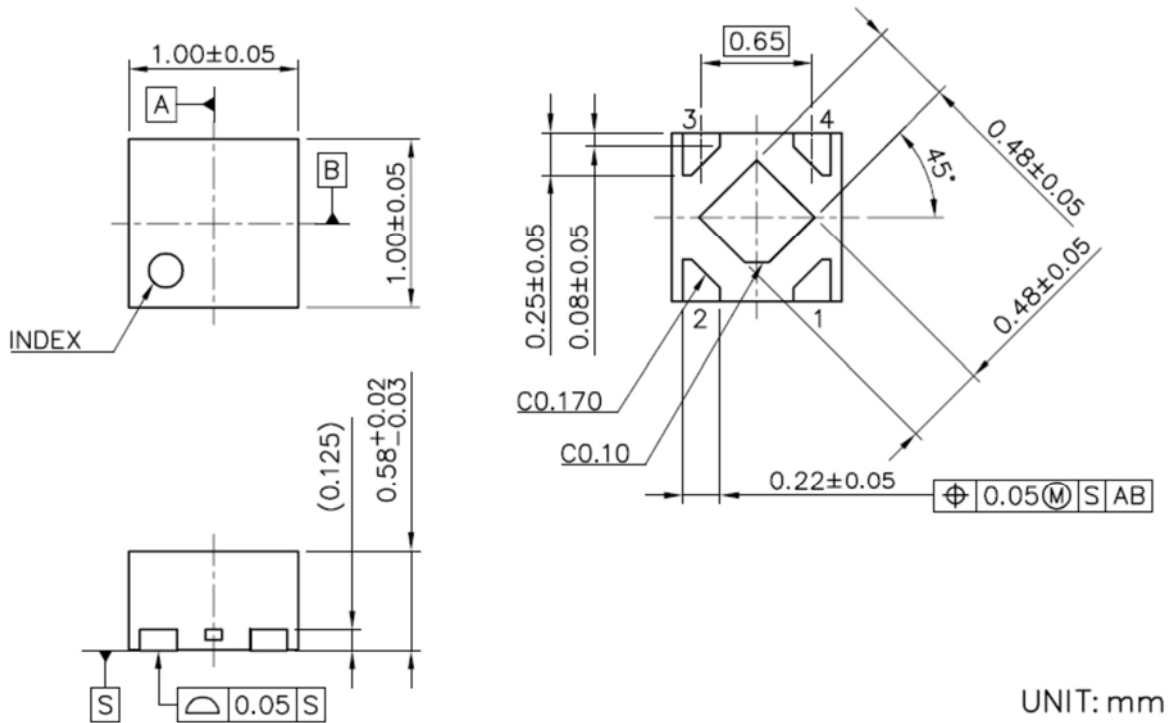

UNIT: mm

DFN (PL) 1010-4B Package Dimensions

* The tab on the bottom of the package is a substrate potential (GND/V_{DD}). It is recommended that this tab be connected to the ground plane/V_{DD} pin on the board but it is possible to leave the tab floating.

①②: Product Code ... Refer to *Part Marking List*

③④: Lot Number ... Alphanumeric Serial Number

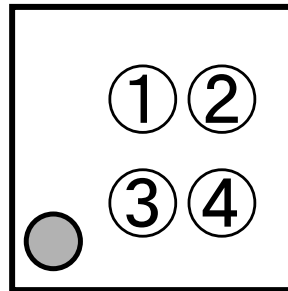

RP114K [DFN(PL)1010-4B], DFN(PL)1010-4 Part Markings

NOTICE

There can be variation in the marking when different AOI (Automated Optical Inspection) equipment is used. In the case of recognizing the marking characteristic with AOI, please contact our sales or our distributor before attempting to use AOI.

RP114Kxx1B Part Marking List

Product Name	①②	Set Output Voltage
RP114K081B	L 0	0.8V
RP114K091B	L 1	0.9V
RP114K101B	L 2	1.0V
RP114K111B	L 3	1.1V
RP114K121B	L 4	1.2V
RP114K131B	L 5	1.3V
RP114K141B	L 6	1.4V
RP114K151B	L 7	1.5V
RP114K161B	L 8	1.6V
RP114K171B	L 9	1.7V
RP114K181B	M 0	1.8V
RP114K191B	M 1	1.9V
RP114K201B	M 2	2.0V
RP114K211B	M 3	2.1V
RP114K221B	M 4	2.2V
RP114K231B	M 5	2.3V
RP114K241B	M 6	2.4V
RP114K251B	M 7	2.5V
RP114K261B	M 8	2.6V
RP114K271B	M 9	2.7V
RP114K281B	N 0	2.8V
RP114K291B	N 1	2.9V
RP114K301B	N 2	3.0V
RP114K311B	N 3	3.1V
RP114K321B	N 4	3.2V
RP114K331B	N 5	3.3V
RP114K341B	N 6	3.4V
RP114K351B	N 7	3.5V
RP114K361B	N 8	3.6V
RP114K121B5	N 9	1.25V
RP114K181B5	P 0	1.85V
RP114K281B5	P 1	2.85V
RP114K341B5	P 2	3.45V
RP114K101B5	P 3	1.05V
RP114K171B5	P 4	1.75V
RP114K111B5	P 5	1.15V
RP114K131B5	P 6	1.35V

RP114Kxx1D Part Marking List

Product Name	①②	Set Output Voltage
RP114K081D	Q 0	0.8V
RP114K091D	Q 1	0.9V
RP114K101D	Q 2	1.0V
RP114K111D	Q 3	1.1V
RP114K121D	Q 4	1.2V
RP114K131D	Q 5	1.3V
RP114K141D	Q 6	1.4V
RP114K151D	Q 7	1.5V
RP114K161D	Q 8	1.6V
RP114K171D	Q 9	1.7V
RP114K181D	R 0	1.8V
RP114K191D	R 1	1.9V
RP114K201D	R 2	2.0V
RP114K211D	R 3	2.1V
RP114K221D	R 4	2.2V
RP114K231D	R 5	2.3V
RP114K241D	R 6	2.4V
RP114K251D	R 7	2.5V
RP114K261D	R 8	2.6V
RP114K271D	R 9	2.7V
RP114K281D	S 0	2.8V
RP114K291D	S 1	2.9V
RP114K301D	S 2	3.0V
RP114K311D	S 3	3.1V
RP114K321D	S 4	3.2V
RP114K331D	S 5	3.3V
RP114K341D	S 6	3.4V
RP114K351D	S 7	3.5V
RP114K361D	S 8	3.6V
RP114K121D5	S 9	1.25V
RP114K181D5	T 0	1.85V
RP114K281D5	T 1	2.85V
RP114K341D5	T 2	3.45V
RP114K101D5	T 3	1.05V
RP114K171D5	T 4	1.75V
RP114K111D5	T 5	1.15V
RP114K131D5	T 6	1.35V

The power dissipation of the package is dependent on PCB material, layout, and environmental conditions. The following conditions are used in this measurement.

Measurement Conditions

Item	Our Evaluation Board
Environment	Mounting on Board (Wind Velocity = 0 m/s)
Board Material	Glass Cloth Epoxy Plastic (Double-Sided Board)
Board Dimensions	40 mm × 40 mm × 1.6 mm
Copper Ratio	Top Side: Approx. 50% Bottom Side: Approx. 50%
Through-holes	φ 0.5 mm × 44 pcs

Measurement Result

(Ta = 25°C, Tjmax = 125°C)

Item	Our Evaluation Board
Power Dissipation	380 mW
Thermal Resistance (θja)	θja = 263°C/W
Thermal Characterization Parameter (ψjt)	ψjt = 75°C/W

θja: Junction-to-Ambient Thermal Resistance

ψjt: Junction-to-Top Thermal Characterization Parameter

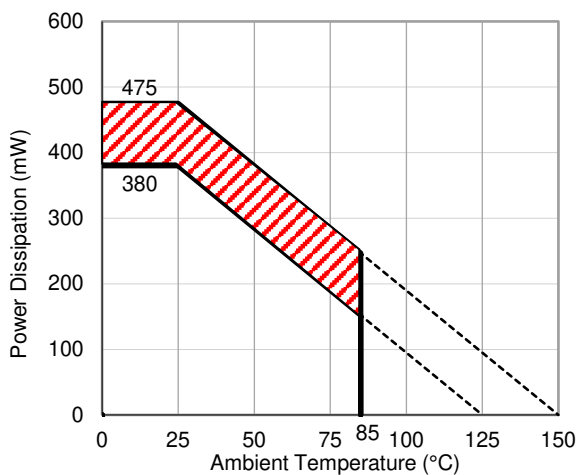

Power Dissipation vs. Ambient Temperature

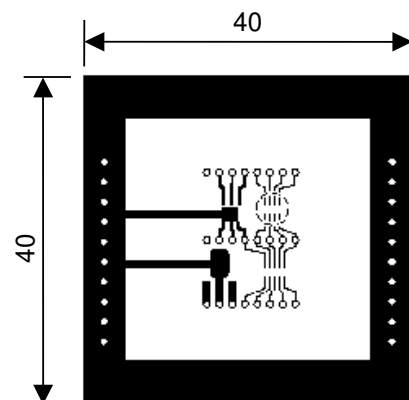

Measurement Board Pattern

The above graph shows the power dissipation of the package at Tjmax = 125°C and Tjmax = 150°C. Operating the device in the hatched range might have a negative influence on its lifetime. The total hours of use and the total years of use must be limited as follows:

Total Hours of Use	Total Years of Use (4 hours/day)
13,000 hours	9 years

PACKAGE DIMENSIONS

SC-88A

DM-SC-88A-JE-A

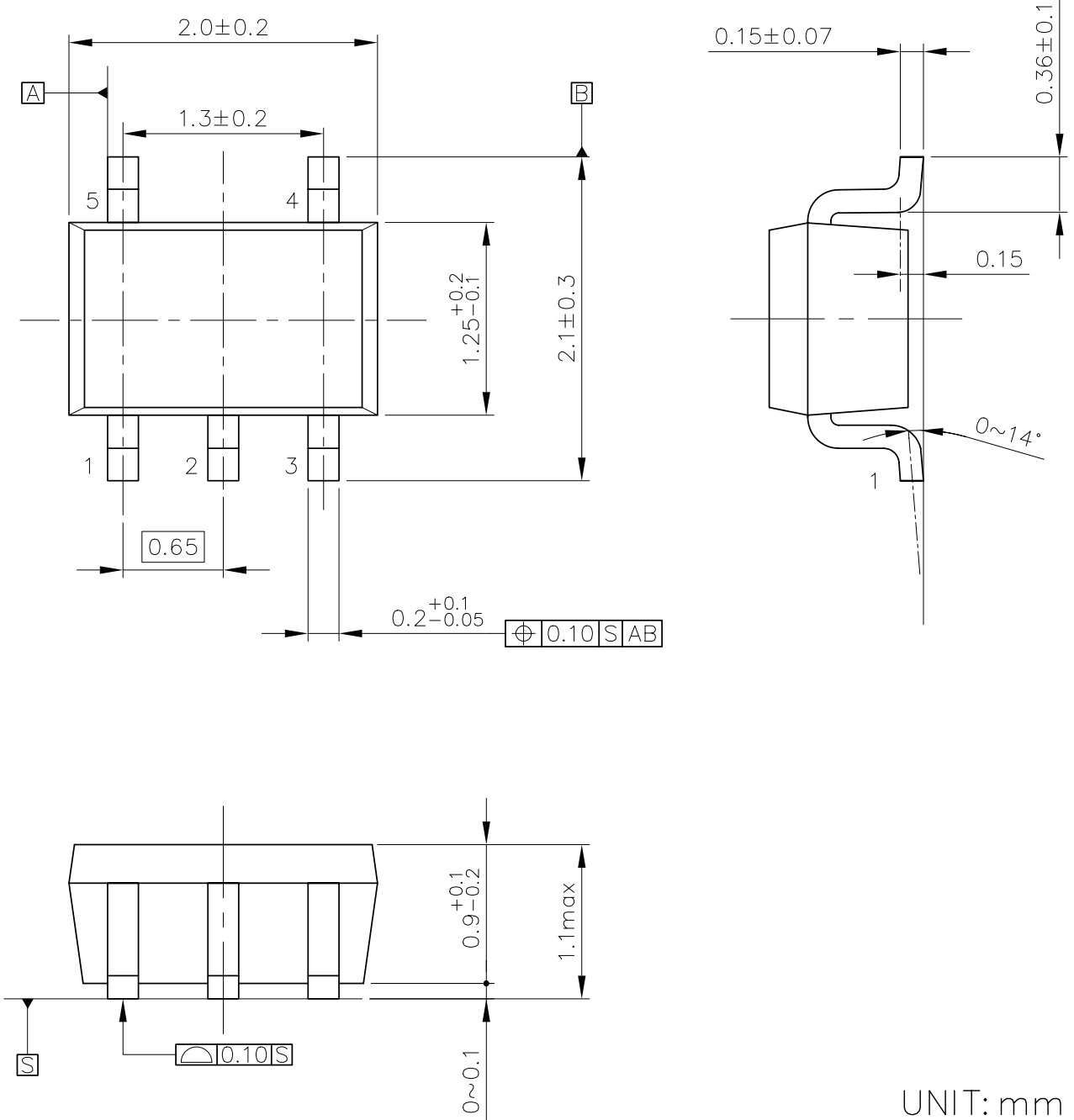

UNIT: mm

SC-88A Package Dimensions

①②③④: Product Code ··· Refer to *Part Marking List*

⑤⑥: Lot Number ··· Alphanumeric Serial Number

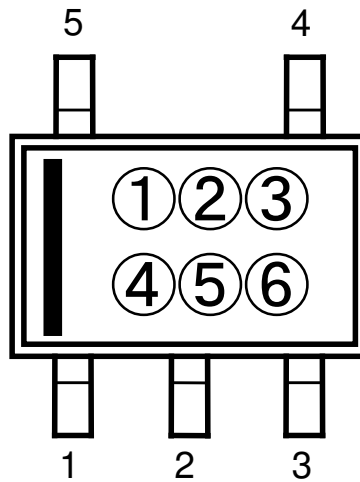

RP114Q (SC-88A) Part Markings

NOTICE

There can be variation in the marking when different AOI (Automated Optical Inspection) equipment is used. In the case of recognizing the marking characteristic with AOI, please contact our sales or our distributor before attempting to use AOI.

RP114Qxx2B Part Marking List

Product Name	①②③④	Set Output Voltage
RP114Q082B	A G 0 8	0.8 V
RP114Q092B	A G 0 9	0.9 V
RP114Q102B	A G 1 0	1.0 V
RP114Q112B	A G 1 1	1.1 V
RP114Q122B	A G 1 2	1.2 V
RP114Q132B	A G 1 3	1.3 V
RP114Q142B	A G 1 4	1.4 V
RP114Q152B	A G 1 5	1.5 V
RP114Q162B	A G 1 6	1.6 V
RP114Q172B	A G 1 7	1.7 V
RP114Q182B	A G 1 8	1.8 V
RP114Q192B	A G 1 9	1.9 V
RP114Q202B	A G 2 0	2.0 V
RP114Q212B	A G 2 1	2.1 V
RP114Q222B	A G 2 2	2.2 V
RP114Q232B	A G 2 3	2.3 V
RP114Q242B	A G 2 4	2.4 V
RP114Q252B	A G 2 5	2.5 V
RP114Q262B	A G 2 6	2.6 V
RP114Q272B	A G 2 7	2.7 V
RP114Q282B	A G 2 8	2.8 V
RP114Q292B	A G 2 9	2.9 V
RP114Q302B	A G 3 0	3.0 V
RP114Q312B	A G 3 1	3.1 V
RP114Q322B	A G 3 2	3.2 V
RP114Q332B	A G 3 3	3.3 V
RP114Q342B	A G 3 4	3.4 V
RP114Q352B	A G 3 5	3.5 V
RP114Q362B	A G 3 6	3.6 V
RP114Q122B5	A G 3 7	1.25 V
RP114Q182B5	A G 3 8	1.85 V
RP114Q282B5	A G 3 9	2.85 V
RP114Q342B5	A G 4 0	3.45 V
RP114Q102B5	A G 4 1	1.05 V

RP114Qxx2D Part Marking List

Product Name	①②③④	Set Output Voltage
RP114Q082D	A H 0 8	0.8 V
RP114Q092D	A H 0 9	0.9 V
RP114Q102D	A H 1 0	1.0 V
RP114Q112D	A H 1 1	1.1 V
RP114Q122D	A H 1 2	1.2 V
RP114Q132D	A H 1 3	1.3 V
RP114Q142D	A H 1 4	1.4 V
RP114Q152D	A H 1 5	1.5 V
RP114Q162D	A H 1 6	1.6 V
RP114Q172D	A H 1 7	1.7 V
RP114Q182D	A H 1 8	1.8 V
RP114Q192D	A H 1 9	1.9 V
RP114Q202D	A H 2 0	2.0 V
RP114Q212D	A H 2 1	2.1 V
RP114Q222D	A H 2 2	2.2 V
RP114Q232D	A H 2 3	2.3 V
RP114Q242D	A H 2 4	2.4 V
RP114Q252D	A H 2 5	2.5 V
RP114Q262D	A H 2 6	2.6 V
RP114Q272D	A H 2 7	2.7 V
RP114Q282D	A H 2 8	2.8 V
RP114Q292D	A H 2 9	2.9 V
RP114Q302D	A H 3 0	3.0 V
RP114Q312D	A H 3 1	3.1 V
RP114Q322D	A H 3 2	3.2 V
RP114Q332D	A H 3 3	3.3 V
RP114Q342D	A H 3 4	3.4 V
RP114Q352D	A H 3 5	3.5 V
RP114Q362D	A H 3 6	3.6 V
RP114Q122D5	A H 3 7	1.25 V
RP114Q182D5	A H 3 8	1.85 V
RP114Q282D5	A H 3 9	2.85 V
RP114Q342D5	A H 4 0	3.45 V
RP114Q102D5	A H 4 1	1.05 V

The power dissipation of the package is dependent on PCB material, layout, and environmental conditions. The following measurement conditions are based on JEDEC STD. 51-7.

Measurement Conditions

Item	Measurement Conditions
Environment	Mounting on Board (Wind Velocity = 0 m/s)
Board Material	Glass Cloth Epoxy Plastic (Four-Layer Board)
Board Dimensions	76.2 mm × 114.3 mm × 0.8 mm
Copper Ratio	Outer Layer (First Layer): Less than 95% of 50 mm Square Inner Layers (Second and Third Layers): Approx. 100% of 50 mm Square Outer Layer (Fourth Layer): Approx. 100% of 50 mm Square
Through-holes	φ 0.3 mm × 7 pcs

Measurement Result

(Ta = 25°C, Tjmax = 125°C)

Item	Measurement Result
Power Dissipation	660 mW
Thermal Resistance (θja)	θja = 150°C/W
Thermal Characterization Parameter (ψjt)	ψjt = 51°C/W

θja: Junction-to-Ambient Thermal Resistance

ψjt: Junction-to-Top Thermal Characterization Parameter

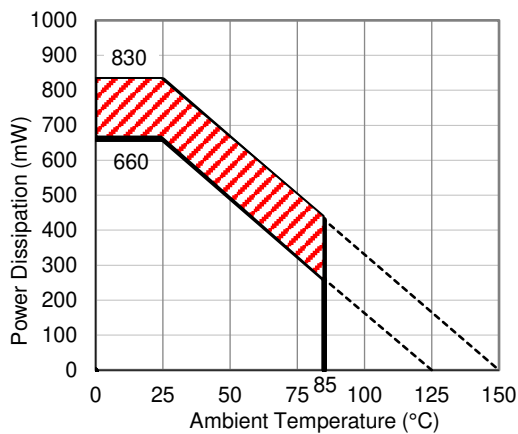

Power Dissipation vs. Ambient Temperature

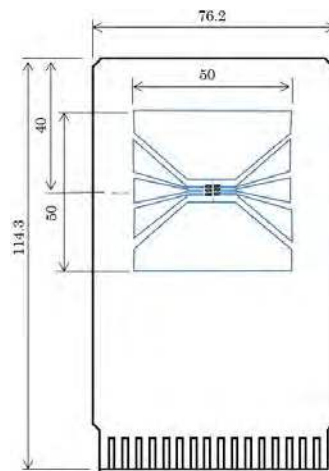

Measurement Board Pattern

The above graph shows the power dissipation of the package at Tjmax = 125°C and Tjmax = 150°C. Operating the device in the hatched range might have a negative influence on its lifetime. The total hours of use and the total years of use must be limited as follows:

Total Hours of Use	Total Years of Use (4 hours/day)
13,000 hours	9 years

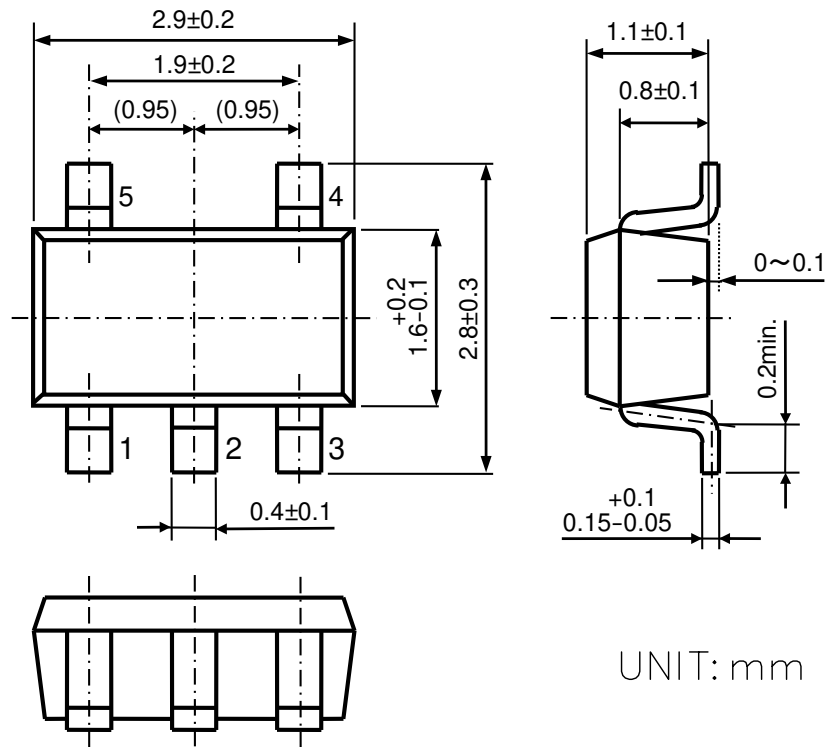

UNIT: mm

SOT-23-5 Package Dimensions

①②③: Product Code ... Refer to *Part Marking List*

④⑤: Lot Number ... Alphanumeric Serial Number

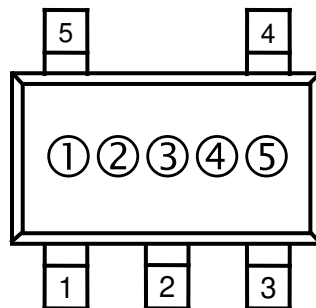

RP114N (SOT-23-5) Part Markings

NOTICE

There can be variation in the marking when different AOI (Automated Optical Inspection) equipment is used. In the case of recognizing the marking characteristic with AOI, please contact our sales or our distributor before attempting to use AOI.

RP114Nxx1B Part Marking List

Product Name	①②③	Set Output Voltage
RP114N081B	Q A A	0.8 V
RP114N091B	Q A B	0.9 V
RP114N101B	Q A C	1.0 V
RP114N111B	Q A D	1.1 V
RP114N121B	Q A E	1.2 V
RP114N131B	Q A F	1.3 V
RP114N141B	Q A G	1.4 V
RP114N151B	Q A H	1.5 V
RP114N161B	Q A J	1.6 V
RP114N171B	Q A K	1.7 V
RP114N181B	Q A L	1.8 V
RP114N191B	Q A M	1.9 V
RP114N201B	Q A N	2.0 V
RP114N211B	Q A P	2.1 V
RP114N221B	Q A Q	2.2 V
RP114N231B	Q A R	2.3 V
RP114N241B	Q A S	2.4 V
RP114N251B	Q A T	2.5 V
RP114N261B	Q A U	2.6 V
RP114N271B	Q A V	2.7 V
RP114N281B	Q A W	2.8 V
RP114N291B	Q A X	2.9 V
RP114N301B	Q A Y	3.0 V
RP114N311B	Q A Z	3.1 V
RP114N321B	R A A	3.2 V
RP114N331B	R A B	3.3 V
RP114N341B	R A C	3.4 V
RP114N351B	R A D	3.5 V
RP114N361B	R A E	3.6 V
RP114N121B5	R A F	1.25 V
RP114N181B5	R A G	1.85 V
RP114N281B5	R A H	2.85 V
RP114N341B5	R A J	3.45 V
RP114N101B5	R A K	1.05 V

RP114Nxx1D Part Marking List

Product Name	①②③	Set Output Voltage
RP114N081D	Q B A	0.8 V
RP114N091D	Q B B	0.9 V
RP114N101D	Q B C	1.0 V
RP114N111D	Q B D	1.1 V
RP114N121D	Q B E	1.2 V
RP114N131D	Q B F	1.3 V
RP114N141D	Q B G	1.4 V
RP114N151D	Q B H	1.5 V
RP114N161D	Q B J	1.6 V
RP114N171D	Q B K	1.7 V
RP114N181D	Q B L	1.8 V
RP114N191D	Q B M	1.9 V
RP114N201D	Q B N	2.0 V
RP114N211D	Q B P	2.1 V
RP114N221D	Q B Q	2.2 V
RP114N231D	Q B R	2.3 V
RP114N241D	Q B S	2.4 V
RP114N251D	Q B T	2.5 V
RP114N261D	Q B U	2.6 V
RP114N271D	Q B V	2.7 V
RP114N281D	Q B W	2.8 V
RP114N291D	Q B X	2.9 V
RP114N301D	Q B Y	3.0 V
RP114N311D	Q B Z	3.1 V
RP114N321D	R B A	3.2 V
RP114N331D	R B B	3.3 V
RP114N341D	R B C	3.4 V
RP114N351D	R B D	3.5 V
RP114N361D	R B E	3.6 V
RP114N121D5	R B F	1.25 V
RP114N181D5	R B G	1.85 V
RP114N281D5	R B H	2.85 V
RP114N341D5	R B J	3.45 V
RP114N101D5	R B K	1.05 V

1. The products and the product specifications described in this document are subject to change or discontinuation of production without notice for reasons such as improvement. Therefore, before deciding to use the products, please refer to our sales representatives for the latest information thereon.
2. The materials in this document may not be copied or otherwise reproduced in whole or in part without the prior written consent of us.
3. This product and any technical information relating thereto are subject to complementary export controls (so-called KNOW controls) under the Foreign Exchange and Foreign Trade Law, and related politics ministerial ordinance of the law. (Note that the complementary export controls are inapplicable to any application-specific products, except rockets and pilotless aircraft, that are insusceptible to design or program changes.) Accordingly, when exporting or carrying abroad this product, follow the Foreign Exchange and Foreign Trade Control Law and its related regulations with respect to the complementary export controls.
4. The technical information described in this document shows typical characteristics and example application circuits for the products. The release of such information is not to be construed as a warranty of or a grant of license under our or any third party's intellectual property rights or any other rights.
5. The products listed in this document are intended and designed for use as general electronic components in standard applications (office equipment, telecommunication equipment, measuring instruments, consumer electronic products, amusement equipment etc.). Those customers intending to use a product in an application requiring extreme quality and reliability, for example, in a highly specific application where the failure or misoperation of the product could result in human injury or death should first contact us.
 - Aerospace Equipment
 - Equipment Used in the Deep Sea
 - Power Generator Control Equipment (nuclear, steam, hydraulic, etc.)
 - Life Maintenance Medical Equipment
 - Fire Alarms / Intruder Detectors
 - Vehicle Control Equipment (automotive, airplane, railroad, ship, etc.)
 - Various Safety Devices
 - Traffic control system
 - Combustion equipment

In case your company desires to use this product for any applications other than general electronic equipment mentioned above, make sure to contact our company in advance. Note that the important requirements mentioned in this section are not applicable to cases where operation requirements such as application conditions are confirmed by our company in writing after consultation with your company.

6. We are making our continuous effort to improve the quality and reliability of our products, but semiconductor products are likely to fail with certain probability. In order to prevent any injury to persons or damages to property resulting from such failure, customers should be careful enough to incorporate safety measures in their design, such as redundancy feature, fire containment feature and fail-safe feature. We do not assume any liability or responsibility for any loss or damage arising from misuse or inappropriate use of the products.
7. The products have been designed and tested to function within controlled environmental conditions. Do not use products under conditions that deviate from methods or applications specified in this datasheet. Failure to employ the products in the proper applications can lead to deterioration, destruction or failure of the products. We shall not be responsible for any bodily injury, fires or accident, property damage or any consequential damages resulting from misuse or misapplication of the products.
8. **Quality Warranty**
 - 8-1. **Quality Warranty Period**

In the case of a product purchased through an authorized distributor or directly from us, the warranty period for this product shall be one (1) year after delivery to your company. For defective products that occurred during this period, we will take the quality warranty measures described in section 8-2. However, if there is an agreement on the warranty period in the basic transaction agreement, quality assurance agreement, delivery specifications, etc., it shall be followed.
 - 8-2. **Quality Warranty Remedies**

When it has been proved defective due to manufacturing factors as a result of defect analysis by us, we will either deliver a substitute for the defective product or refund the purchase price of the defective product.

Note that such delivery or refund is sole and exclusive remedies to your company for the defective product.
 - 8-3. **Remedies after Quality Warranty Period**

With respect to any defect of this product found after the quality warranty period, the defect will be analyzed by us. On the basis of the defect analysis results, the scope and amounts of damage shall be determined by mutual agreement of both parties. Then we will deal with upper limit in Section 8-2. This provision is not intended to limit any legal rights of your company.
9. Anti-radiation design is not implemented in the products described in this document.
10. The X-ray exposure can influence functions and characteristics of the products. Confirm the product functions and characteristics in the evaluation stage.
11. WLCSP products should be used in light shielded environments. The light exposure can influence functions and characteristics of the products under operation or storage.
12. Warning for handling Gallium and Arsenic (GaAs) products (Applying to GaAs MMIC, Photo Reflector). These products use Gallium (Ga) and Arsenic (As) which are specified as poisonous chemicals by law. For the prevention of a hazard, do not burn, destroy, or process chemically to make them as gas or power. When the product is disposed of, please follow the related regulation and do not mix this with general industrial waste or household waste.
13. Please contact our sales representatives should you have any questions or comments concerning the products or the technical information.



Nisshinbo Micro Devices Inc.

Official website

<https://www.nisshinbo-microdevices.co.jp/en/>

Purchase information

<https://www.nisshinbo-microdevices.co.jp/en/buy/>