



### Electrical specifications

**Center Frequency:** 5350 MHz  
**Bandwidth:** 500 MHz  
**Input / Output Impedance:** 50 Ohms  
**Passband:** 5100-5600 MHz  
**Passband Insertion Loss:** < 1.5 dB  
**Passband Ripple:** <0.2 dB  
**Passband Return Loss:** >10 dB  
**Rejection:** >70 @ 5735-5835 MHz  
**Power Handling:** 35 W

### Mechanical

**Mounting Method:** Threaded Mounting Holes  
**Connector Type:** N-Type (F) and N-Type (F)  
**Dimensions:** 3.937" x 2.047" x 0.984"  
(100mm x 52mm x 26mm)

### Environmental

**Operating Temperature:** -10 to +50 deg.C  
**Storage Temperature:** -55 to +95 deg.C  
**Shock:** 20 G. 11ms  
**Vibration:** 20 G. 5 to 200 MHz

### Outline Drawing:

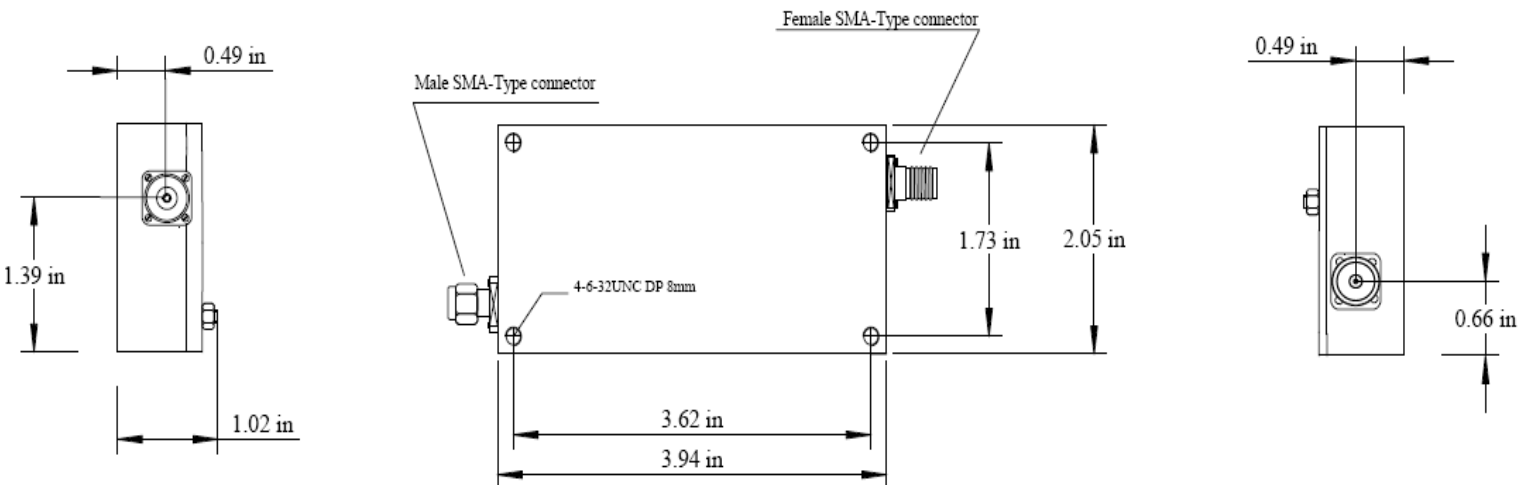



### Response Plot:

