

LOC		DIST		REVISIONS			
GP	00	F	LTR	DESCRIPTION	DATE	DMN	APVD
		F		REVISED PER ECR-11-006470	12JUL11	HMR	SM
		G		ECR-13-008537	16SEP13	M.T	D.Z

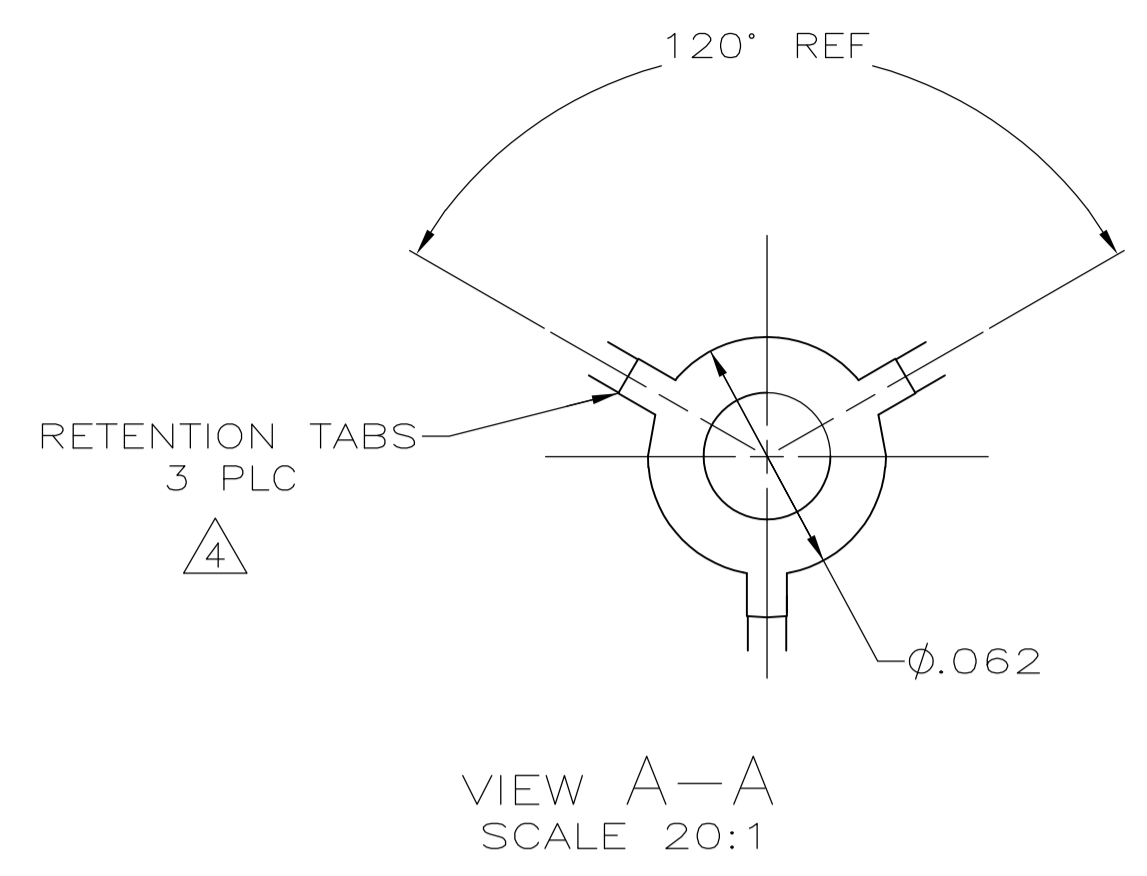

- 1 MATERIAL: HEADER - POLYESTER UL94V-0 (BLACK)  
POST - COPPER ALLOY.
- 2 SOLDER SIDE OF P.C. BOARD SHOWN.
- 3 PARTS COMPLY WITH TYCO ELECTRONICS SOLDERABILITY SPEC 109-11-12 (TIN).
- 4 THE RETENTION TABS PROVIDE A ONE-TIME INTERFERENCE FIT IN THE .078 DIAMETER BOARD HOLE FOR HEADER ASSEMBLY RETENTION DURING SOLDERING.
- 5 LATCH DETENT FEATURE OCCURS 2 PLACES ON EACH END (MAXIMUM OF FOUR PER PART). FOR 2 THRU 5 CIRCUIT.
- 6 COORDINATE DIMENSION APPLIES FROM CENTER OF ACTUAL FEATURE.
- 7 GOLD PLATE, .000030 MIN, FOUR SIDES AS SHOWN, OVER NICKEL UNDERPLATE, .000050 MIN, ALL SIDES AND ENTIRE LENGTH OF POST.  
OR  
GOLD FLASH OVER PALLADIUM-NICKEL, .000030 MIN TOTAL THICKNESS AS SHOWN, OVER NICKEL UNDERPLATE .000050 MIN ALL SIDES AND LENGTH OF POST. EITHER PLATING MAY BE PROVIDED AT THE DISCRETION OF TYCO ELECTRONICS.
- 8 TIN PLATE, ALL FOUR SIDES, .140 REF.
- 9 POST MUST WITHSTAND 3.0 LBS (13.34 NEWTONS) MIN FORCE WITHOUT DISLODGING, EITHER DIRECTION.
- 10 SLOTS MAY OR MAY NOT APPEAR ON THESE PARTS.
- 11 MATTE TIN (100%) PLATE, ALL FOUR SIDES, .140 REF.
- 12 UL RECOGNIZED ( UR ) LOGO AND CSA LOGO ON THE SIDE OF THE PART. AMP LOGO MAY APPEAR ON THE SIDE OR ON THE BOTTOM OF THE PART.

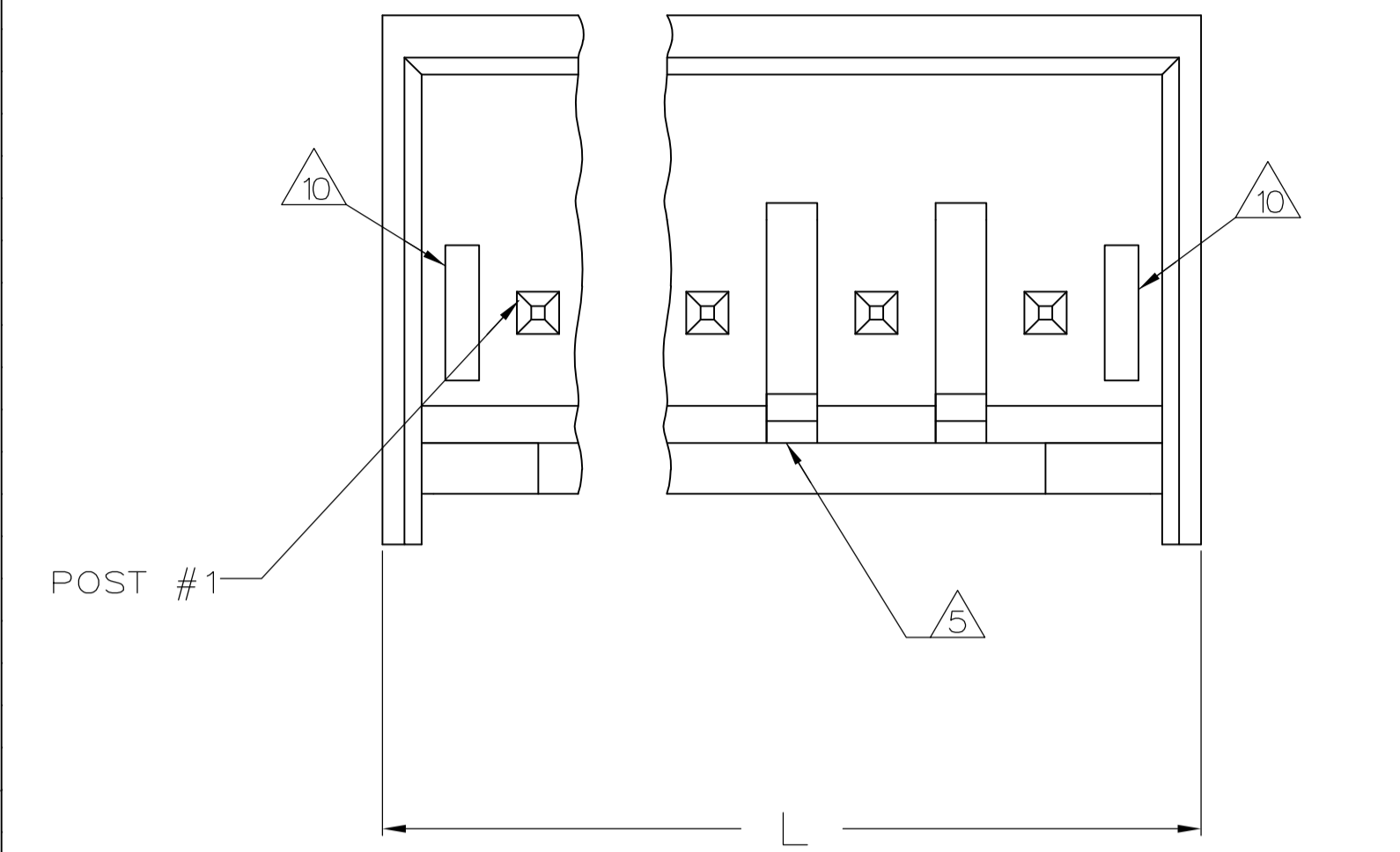
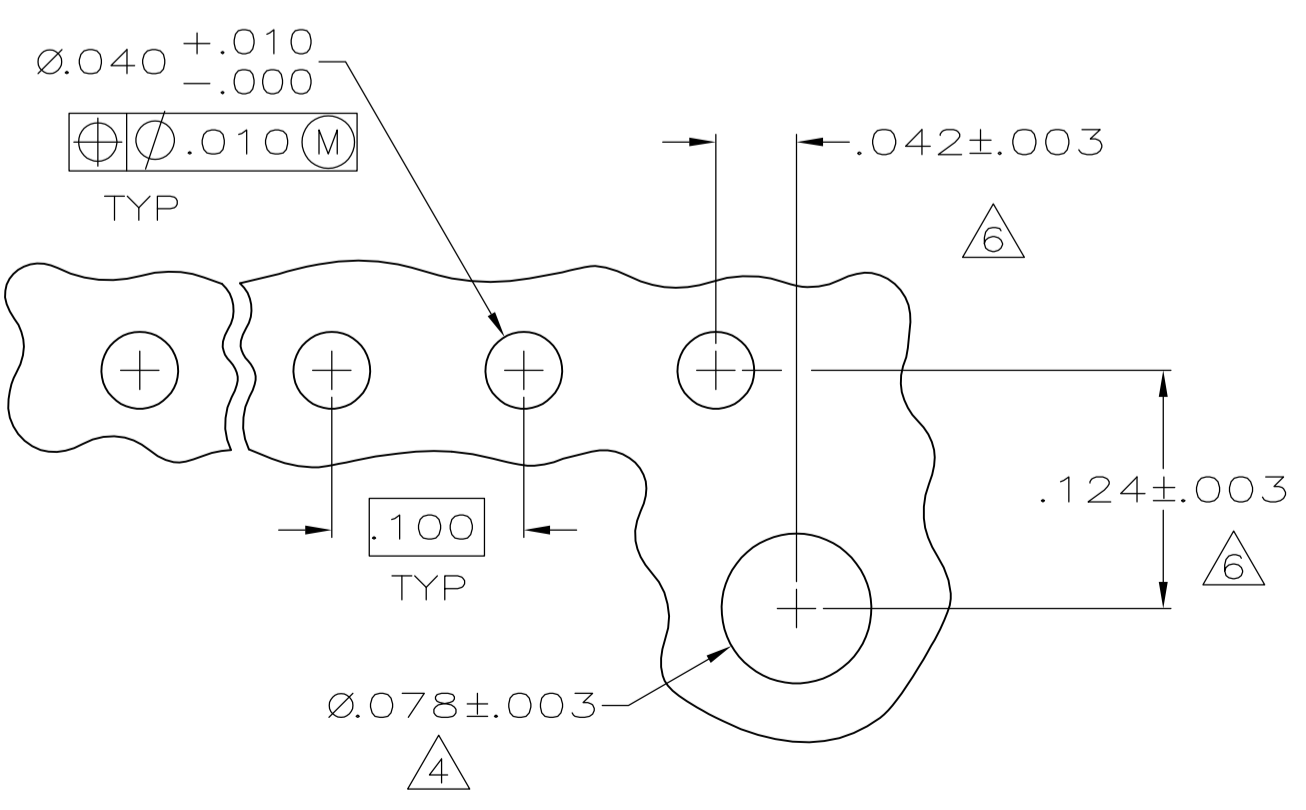
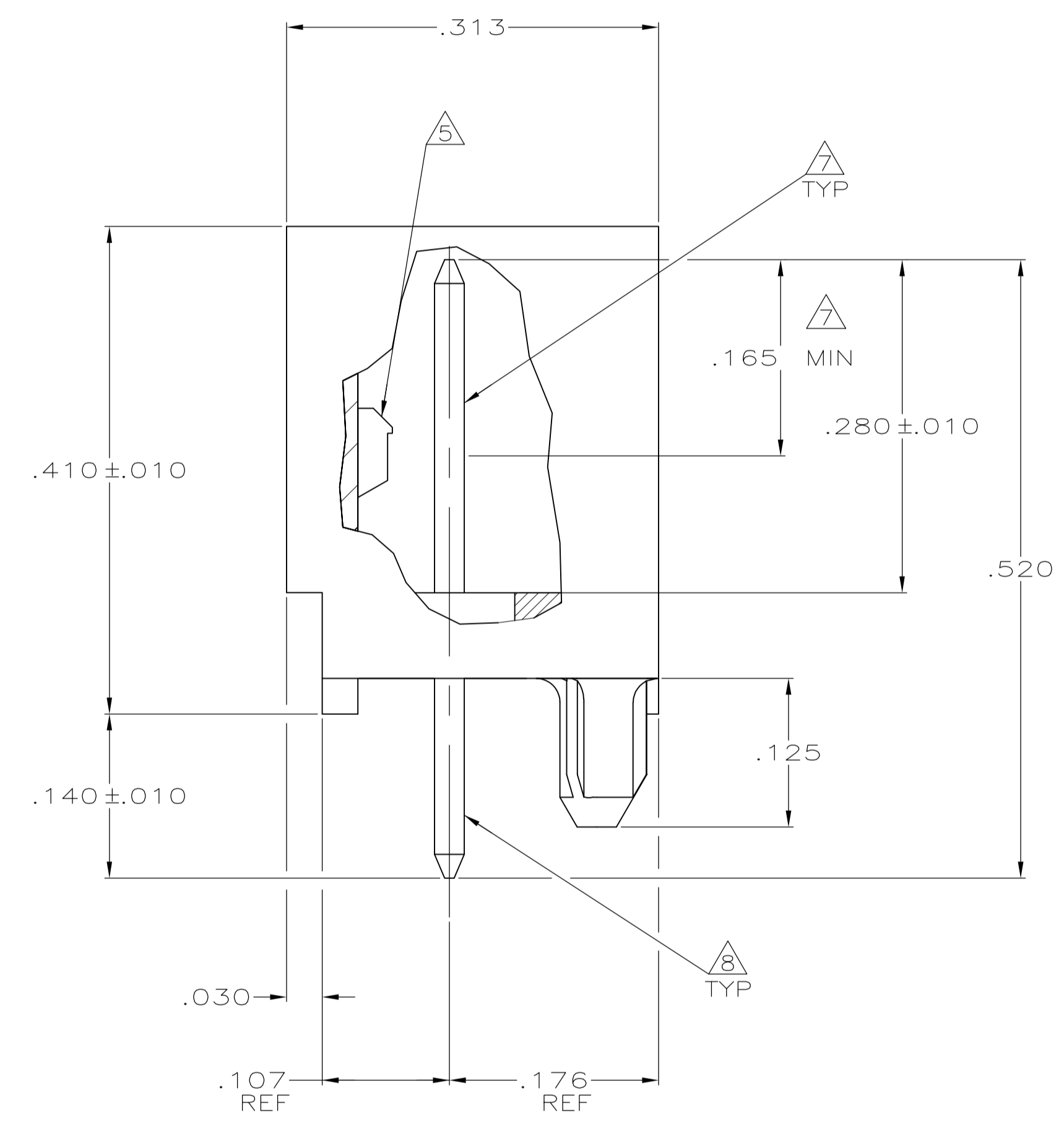
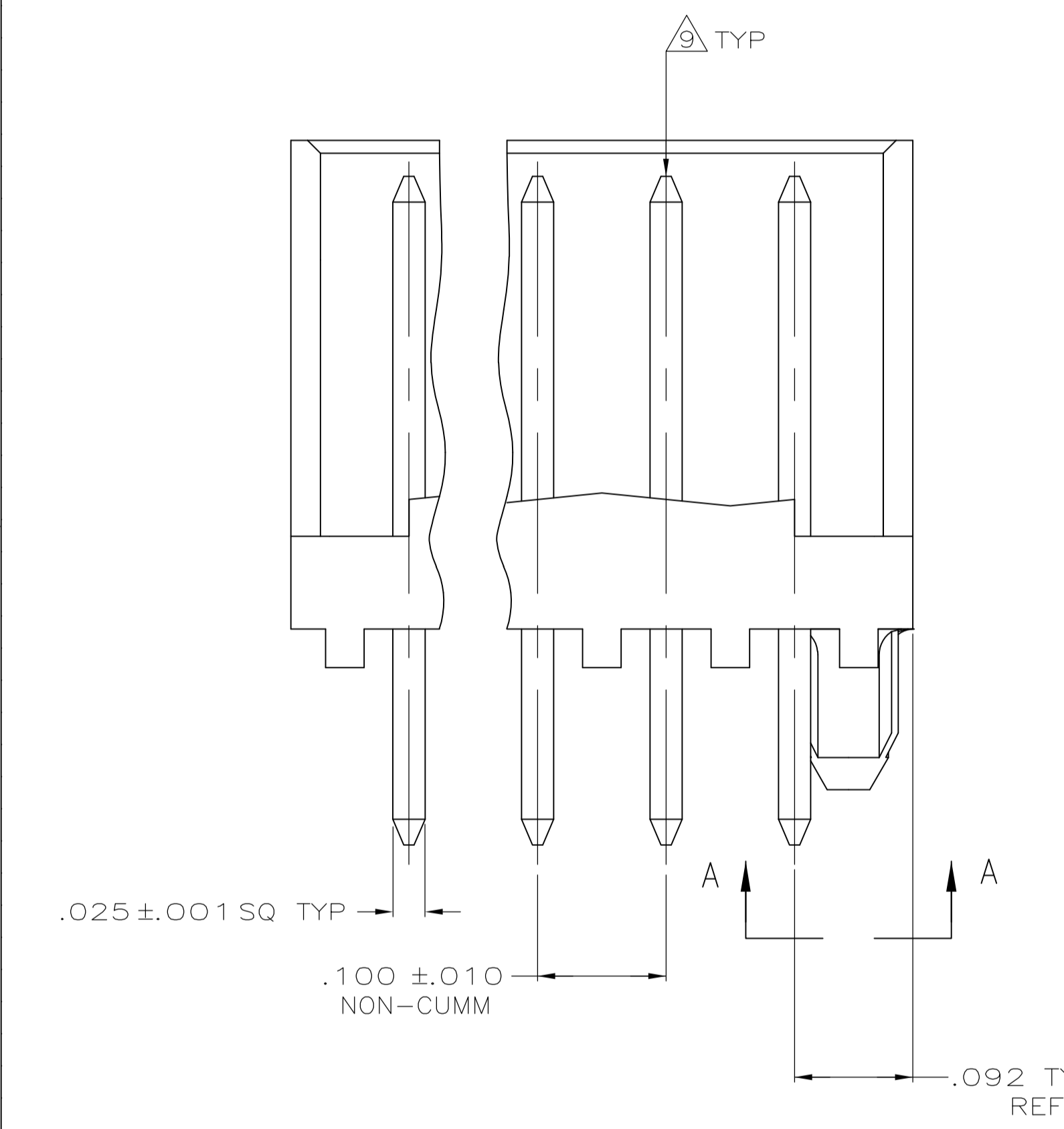

	.025	0.64	.124	3.15	-	-
	.010	0.25	.107	2.72	-	-
	.005	0.13	.100	2.54	.520	13.21
	.003	0.08	.092	2.34	.410	10.41
	.001	0.03	.078	1.98	.313	7.95
	.000350	0.00889	.063	1.60	.280	7.11
	.000150	0.00381	.062	1.57	.176	4.47
	.000050	0.00127	.042	1.07	.165	4.19
	.000030	0.00076	.040	1.02	.140	3.56
	.000	0.00	.030	0.76	.125	3.18
	IN	MM	IN	MM	IN	MM

CONVERSION TABLE

IN	MM	NO OF POSITIONS	PART NUMBER
1.484	37.69	14	4-644897-4
1.384	35.15	13	4-644897-3
1.284	32.61	12	4-644897-2
1.184	30.07	11	4-644897-1
1.084	27.53	10	4-644897-0
.984	24.99	9	3-644897-9
.884	22.45	8	3-644897-8
.784	19.91	7	3-644897-7
.684	17.37	6	3-644897-6
.584	14.83	5	3-644897-5
.484	12.29	4	3-644897-4
.384	9.75	3	3-644897-3
.284	7.21	2	3-644897-2

RECOMMENDED MOUNTING HOLE PATTERN FOR .063 THK PRINTED CIRCUIT BOARD

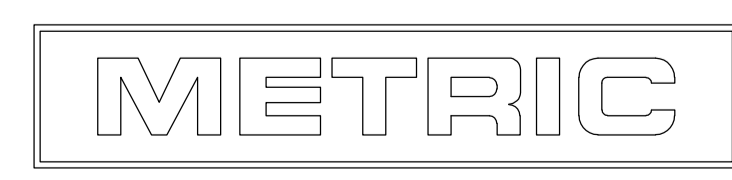

THIS DRAWING IS A CONTROLLED DOCUMENT.

DIN K. WHITAKER 27JUNE2005  
CHK D. ROSSI 27JUNE2005  
APVD D. ROSSI 27JUNE2005

NAME: CST-100 SHROUDED HEADER ASSEMBLY, FRICTION LOCK, STRAIGHT POST, .000030 GOLD

APPLICATION SPEC: PRODUCT SPEC

SIZE: A1 CASE CODE: 00779 DRAWING NO: 644897

WEIGHT: RESTRICTED TO: CUSTOMER DRAWING

SCALE: 10:1 SHEET 1 OF 1 REV G