

PART NUMBER	REVISION	DESCRIPTION	FEED TYPE
2150157-1	K	FINE CRIMP HEIGHT ADJUST	MECHANICAL
2150157-2	K	FINE CRIMP HEIGHT ADJUST	PNEUMATIC
7-2150157-1	K	MECHANICAL AND CRIMP TOOLING KIT	MECHANICAL
7-2150157-2	K	PNEUMATIC AND CRIMP TOOLING KIT	PNEUMATIC
7-2150157-7	A	CRIMP TOOLING KIT	-

ATLANTIC VERSION TERMINATOR INTERFACE ADAPTER

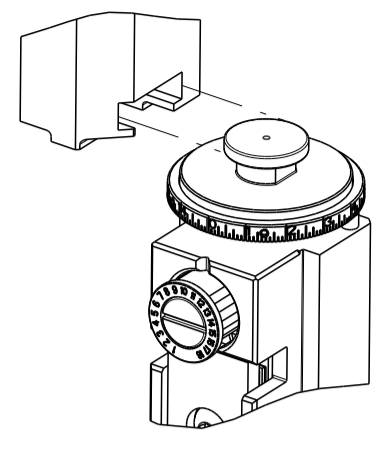

APPLICATOR DATA		
CRIMP	SIZE	TYPE
WIRE	2.79 mm [.110]	F
INSUL	3.56 mm [.140]	OV
APPL INSTRUCTIONS 408-35043		

TERMINAL DATA: TE TERMINAL TE CRIMP SPECIFICATION			
TERMINAL NAME: .250 SRS FASTIN-ON REC			
WIRE STRIP LENGTH		INSULATION DIAMETER RANGE	
.228-.260 IN [5.79-6.60 mm]		Ø.083-.122 IN [2.11-3.10 mm]	
TERMINAL APPLICATION SPECIFICATION	114-18022		
TERMINALS APPLIED <sup>5</sup>			
TE TERMINAL	TE TERMINAL	TE TERMINAL	TE TERMINAL
160917-1	160917-2	160917-3	160917-4

WIRE SIZE	CRIMP HEIGHT mm [INCH]	CRIMP HEIGHT REFERENCE SETTING
2.50mm2	2.04 +/- 0.05 [.080 +/- .002]	6.7
2.00mm2	1.90 +/- 0.05 [.075 +/- .002]	8.5
1.50mm2	1.76 +/- 0.05 [.069 +/- .002]	9.9

- <sup>1</sup> RECOMMENDED SPARE PARTS
  - <sup>2</sup> REFER TO SUPPLIED INSTRUCTION SHEET FOR CLEANING, LUBRICATION AND STORAGE OF APPLICATOR.
  - <sup>3</sup> APPLY PART NUMBER 2-23419-6 LOCTITE TO THREADS OF ITEM 242. APPLY PART NUMBER 1-23419-5 LOCTITE TO THREADS OF ITEM 50.
  - <sup>4</sup> CRIMP HEIGHT REFERENCE SETTING WAS THE SETTING USED WHEN THE APPLICATOR WAS QUALIFIED AT THE FACTORY. ADJUSTMENT MAY BE NECESSARY WHEN RUNNING APPLICATOR IN THE FIELD.
  - <sup>5</sup> TERMINAL LUBRICANT IS RECOMMENDED.
6. UNLESS SPECIFIED OTHERWISE TORQUE VALUES SHALL BE USED PER DOCUMENT, 101-35000.

**\*WARNING**  
ON INSTALLATION, SET WIRE DISC TO CRIMP HEIGHT REFERENCE SETTING FOR LARGEST WIRE SIZE. CRIMP HEIGHT REFERENCE SETTINGS GREATER THAN THE VALUE SHOWN MAY CAUSE DAMAGE TO THE CRIMP TOOLING. REFER TO THE INSTRUCTION SHEET FOR PROPER SETUP AND ADJUSTMENTS.

ATLANTIC VERSION  
Shown on sheets 1 of 4 & 2 of 4  
(Pacific version shown on sheets 3 of 4 & 4 of 4)

LOC	DIST	REVISIONS					
A	66	P	LTN	DESCRIPTION	DATE	DWN	APVD
		G		ECR-17-003382	10MAR2017	TB	TE
		H		ECR-18-015559	30SEP2018	TB	TE
		J		ECR-22-131027	01MAR2022	JWC	RK
		K		ECR-23-181263	13JUL2023	ROY	JAH

-	1	-	1	-	2119641-1	FEED CAM, AIR FEED	248
-	1	1	1	1	2119082-9	CAM, SNAIL, INSULATION ADJUSTMENT	244
-	1	1	1	1	2079764-1	WASHER, WAVE SPRING, CREST-TO-CREST	243
<sup>3</sup>	-	1	1	1	2119083-1	RETAINER, INSULATION DIAL	242
-	-	1	-	1	2119580-1	MECHANICAL FEED ASSEMBLY	239
-	1	-	1	-	2844940-3	AIR FEED MODULE	238
-	1	1	1	1	1-18028-0	WASHER, FLAT, REG M8	192
-	1	1	1	1	6-993111-6	PIN, SLOTTED SPRING 3.0 X 14.0	177
-	1	1	1	1	8-22280-7	SPRING, COMPRESSION	176
-	1	1	1	1	1752353-2	GUIDE PIN, HOLDDOWN	175
-	1	1	1	1	1901680-2	GUIDE PIN, HOLDDOWN	174
-	REF	REF	REF	REF	994970-2	COUNTER, MAGNETIC	164
<sup>5</sup>	-	1	1	1	2119955-2	ASSY, LUBRICATOR, END FEED	84
-	1	1	1	1	455888-3	SPACER, CRIMPER	82
-	1	1	1	1	1803607-4	DOCUMENTATION PACKAGE	71
-	2	2	2	2	2-18032-2	SCR, SET, FLT PNT, M3 X 10.0	70
-	1	1	1	1	2119740-1	TAG, IDENTIFICATION	67
-	2	2	2	2	2168078-1	SCREW, DRIVE, RH, RoHS, 2 x .188	66
-	1	1	1	1	1901681-1	HOLDDOWN, TERMINAL	65
-	2	2	2	2	2168400-5	SHCS, LOW HEAD, RoHS, M4 X 20	64
-	1	1	1	1	2168083-2	SCR, SKT HD CAP, RoHS, M4 X 8.0	60
-	1	1	1	1	5-18022-5	SCR, HEX HD CAP, M4 X 6.0	59
-	-	1	-	1	2063961-1	FEED FINGER	58
-	3	3	3	3	2168400-4	SHCS, LOW HEAD, RoHS, M4 X 8	57
-	2	2	2	2	1-2168083-0	SCR, SKT HD CAP, RoHS, M4 X 10	56
-	2	2	2	2	5018030-1	NUT, HEX, REG, RoHS, M3	54
-	2	2	2	2	986965-8	NUT, LOCK, HEX, TORQUE (M4)	53
-	1	1	1	1	1-5018030-0	NUT, HEX, REG, RoHS, M3.5	52
-	1	-	1	-	2063961-1	FEED FINGER	51
<sup>3</sup>	-	1	1	1	1-1976055-2	STANDOFF, HOLD-DOWN	50
-	1	2	1	2	18023-9	SCR, SKT HD CAP M4 X 6.0	49
-	-	1	-	1	2119652-1	FEED CAM, PRE FEED	48
-	-	1	-	1	2119653-1	FEED CAM, POST FEED	47
-	1	1	1	1	2119655-5	APPLICATOR BASIC ASSEMBLY, EF	46
-	1	1	1	1	1803517-1	RAM ASSEMBLY, EF ATLANTIC	44
-	1	1	1	1	1803602-1	SCR, BHSC, RoHS (M8 X 25)	41
-	7	7	7	7	1-18028-2	WASHER, FLAT, REG M4	33
-	2	2	2	2	2168083-9	SCR, SKT HD CAP, RoHS, M4 X 20	31
-	2	2	2	2	2168083-2	SCR, SKT HD CAP, RoHS, M4 X 8.0	29
-	1	1	1	1	240639-1	STRIPPER (MACHINING)	27
-	2	2	2	2	1-2168083-5	SCR, SKT HD CAP, RoHS, M4 X 30	25
-	1	1	1	1	1752371-3	PLATE, STRIP GUIDE	24
-	1	1	1	1	240825-1	PLATE, STRIP HOLD DOWN	23
-	2	2	2	2	2-22281-3	SPRING, COMPRESSION	22
-	1	1	1	1	1803292-1	DRAG	20
-	2	2	2	2	1901259-6	GUIDE, LOWER STRIP	18
-	4	4	4	4	1-2079383-1	SCR, BHSC, RoHS (M6 X 12)	17
-	1	1	1	1	240641-2	SPACER	16
-	1	1	1	1	1752360-1	SPACER, HOLD-DOWN	13
<sup>1</sup>	-	1	1	1	240833-4	PLATE, REAR SHEAR	11
-	-	-	-	-	-	-	10
<sup>1</sup>	-	1	1	1	690482-4	PLATE, FRONT SHEAR	9
<sup>1</sup>	1	2	2	1	1333219-6	ANVIL, COMBINATION	8
<sup>1</sup>	-	1	1	1	1-2217206-2	BLADE, SLUG	7
-	1	1	1	1	1-240641-6	SPACER	5
-	1	1	1	1	238011-2	BLOCK, CRIMPER SPACER	4
<sup>1</sup>	1	2	2	1	2-2119785-6	CRIMPER, INSULATION OVERLAP PREMIUM	3
-	1	1	1	1	455888-7	SPACER, CRIMPER	2
<sup>1</sup>	1	2	2	1	456408-9	CRIMPER, WIRE PREMIUM	1
					-77-72-71-2-1	PART NO	ITEM NO

DIMENSIONS:		TOLERANCES UNLESS OTHERWISE SPECIFIED:		DRAWING NO	
mm	0 PLC	±		100CT2012	
	1 PLC	±		100CT2012	
	2 PLC	±			
	3 PLC	±			
	4 PLC	±			
	ANGLES	±			
	FINISH	±			
MATERIAL				WEIGHT	
Customer Accessible Production Drawing				SCALE	1:1
				SHEET	1 of 4
				REV	K

LOC	DIST	REV	DESCRIPTION	DATE	OWN	APVD
A	66		SEE SHEET 1			

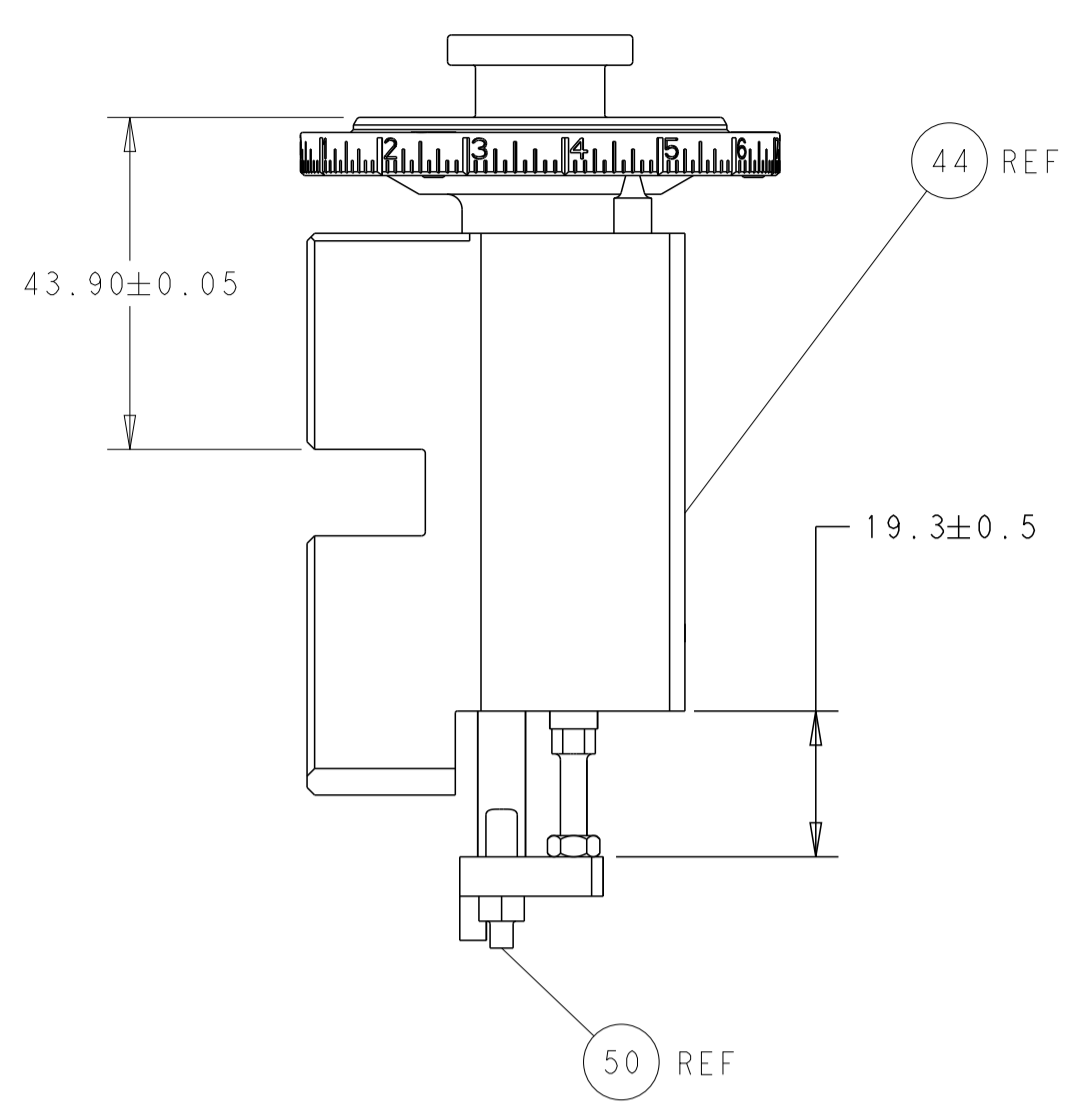

RAM AND HOLDDOWN SET-UP

FEED TYPE  
MECHANICAL

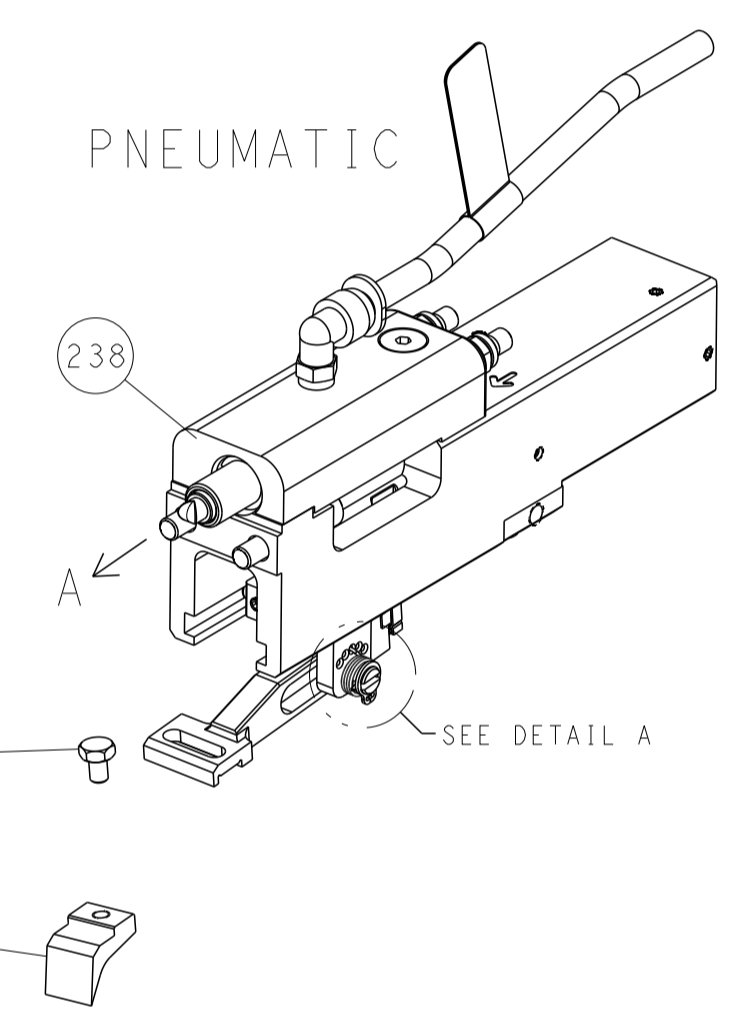
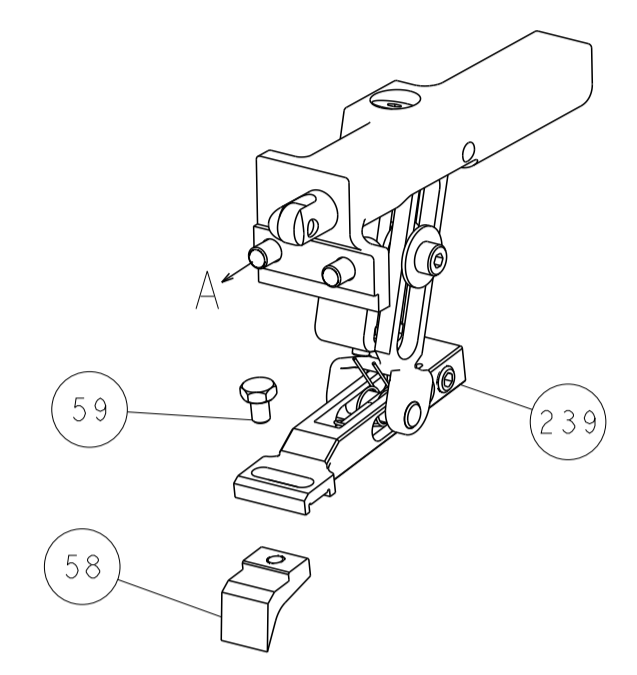

PNEUMATIC

FEED SPRING  
SETTING POSITION

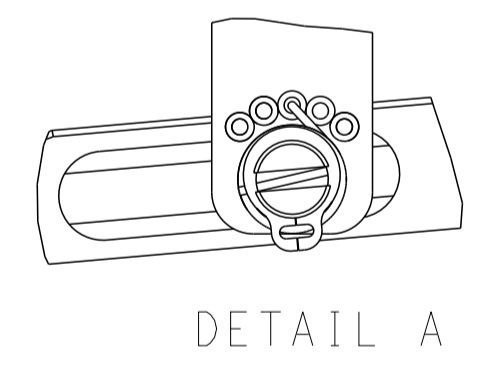

DETAIL A

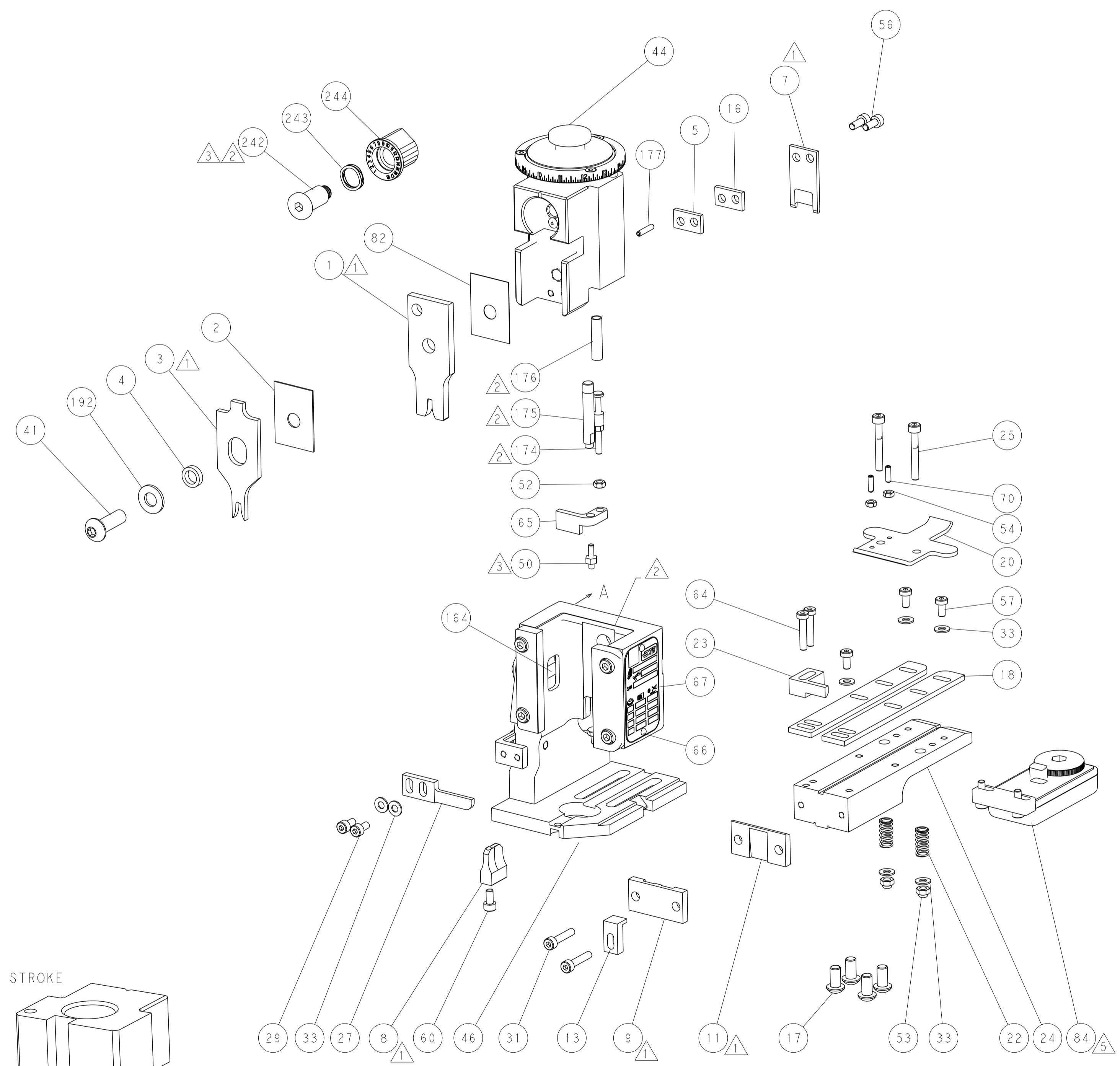

CAM POSITIONS

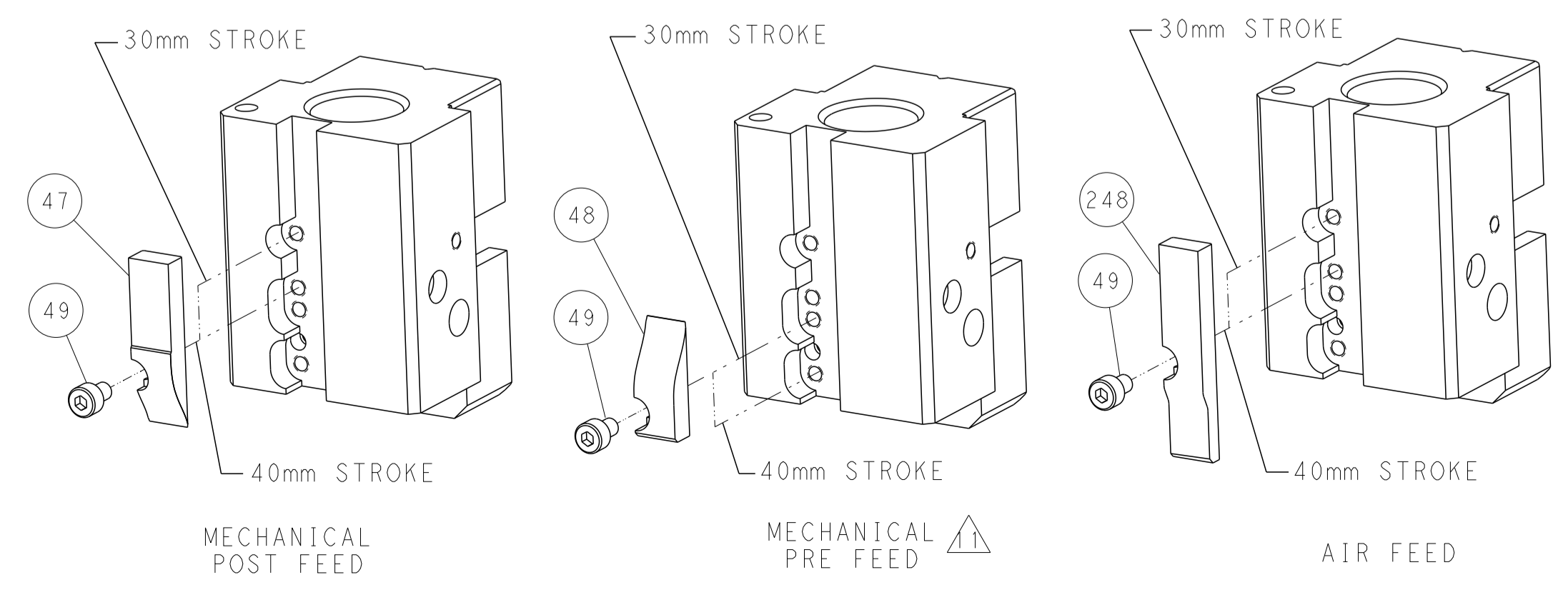

**ATLANTIC VERSION**  
 Shown on sheets 1 of 4 & 2 of 4  
 (Pacific version shown on sheets 3 of 4 & 4 of 4)

DIMENSIONS: mm 		TOLERANCES UNLESS OTHERWISE SPECIFIED: 0 PLC ± 1 PLC ± 2 PLC ± 3 PLC ± 4 PLC ± ANGLES ± FINISH		DWN C. CHEN 10OCT2012 CHK S. XI 10OCT2012 APVD J. CRUZ 10OCT2012 PRODUCT SPEC APPLICATION SPEC WEIGHT SCALE 1:1 SHEET 2 OF 4 REV K		NAME Ocean End Feed Applicator SIZE CAGE CODE DRAWING NO A1 00779 ©=2150157 RESTRICTED TO	
THIS DRAWING IS UNPUBLISHED. RELEASED FOR PUBLICATION BY TYCO ELECTRONICS CORPORATION. ALL RIGHTS RESERVED.				TE Connectivity Harrisburg, PA 17105-3608 Customer Accessible Production Drawing			

PART NUMBER	REVISION	DESCRIPTION	FEED TYPE
2-2150157-1	K	FINE CRIMP HEIGHT ADJUST	MECHANICAL
2-2150157-2	K	FINE CRIMP HEIGHT ADJUST	PNEUMATIC
7-2150157-7	A	CRIMP TOOLING KIT	-

PACIFIC VERSION TERMINATOR  
 INTERFACE ADAPTER

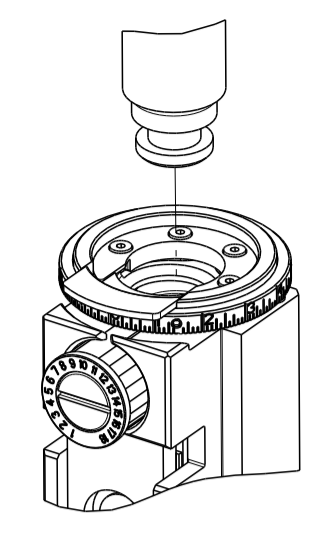

APPLICATOR DATA

CRIMP	SIZE	TYPE
WIRE	2.79 mm (.110)	F
INSUL	3.56 mm (.140)	OV

APPL INSTRUCTIONS  
 408-35043

TERMINAL DATA: TE TERMINAL TE CRIMP SPECIFICATION

TERMINAL NAME: .250 SRS FAST-IN-ON REC

WIRE STRIP LENGTH	INSULATION DIAMETER RANGE
.228-.260 IN [5.79-6.60 mm]	Ø.083-.122 IN [2.11-3.10 mm]

TERMINAL APPLICATION SPECIFICATION

TE TERMINAL	TE TERMINAL	TE TERMINAL	TE TERMINAL
160917-1	160917-2	160917-3	160917-4

WIRE SIZE	CRIMP HEIGHT mm [INCH]	CRIMP HEIGHT REFERENCE SETTING
2.50mm2	2.04+/-0.05 [.080+/-0.002]	6.7
2.00mm2	1.90+/-0.05 [.075+/-0.002]	8.5
1.50mm2	1.76+/-0.05 [.069+/-0.002]	9.9

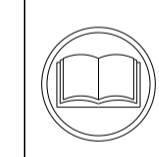

- 1 RECOMMENDED SPARE PARTS
- 2 REFER TO SUPPLIED INSTRUCTION SHEET FOR CLEANING, LUBRICATION AND STORAGE OF APPLICATOR.
- 3 APPLY PART NUMBER 2-23419-6 LOCTITE TO THREADS OF ITEM 242. APPLY PART NUMBER 1-23419-5 LOCTITE TO THREADS OF ITEM 50.
- 4 CRIMP HEIGHT REFERENCE SETTING WAS THE SETTING USED WHEN THE APPLICATOR WAS QUALIFIED AT THE FACTORY. ADJUSTMENT MAY BE NECESSARY WHEN RUNNING APPLICATOR IN THE FIELD.
- 5 TERMINAL LUBRICANT IS RECOMMENDED.
- 6. UNLESS SPECIFIED OTHERWISE TORQUE VALUES SHALL BE USED PER DOCUMENT, 101-35000.

**\*WARNING**  
 ON INSTALLATION, SET WIRE DISC TO CRIMP HEIGHT REFERENCE SETTING FOR LARGEST WIRE SIZE. CRIMP HEIGHT REFERENCE SETTINGS GREATER THAN THE VALUE SHOWN MAY CAUSE DAMAGE TO THE CRIMP TOOLING. REFER TO THE INSTRUCTION SHEET FOR PROPER SETUP AND ADJUSTMENTS.

PACIFIC VERSION  
 Shown on sheets 3 of 4 & 4 of 4  
 (Atlantic version shown on sheets 1 of 4 & 2 of 4)

LOC	DIST	REVISIONS					
A	66	P	LTN	DESCRIPTION	DATE	OWN	APVD
-	-	-	-	SEE SHEET 1	-	-	-

-	1	1	2119082-9	CAM, SNAIL, INSULATION ADJUSTMENT	244	
-	1	1	2079764-1	WASHER, WAVE SPRING, CREST-TO-CREST	243	
-	1	1	2119083-1	RETAINER, INSULATION DIAL	242	
-	-	1	2119580-1	MECHANICAL FEED ASSEMBLY	239	
-	1	-	2844940-3	AIR FEED MODULE	238	
-	1	1	1-18028-0	WASHER, FLAT, REG M8	192	
-	4	4	2079383-9	SCR, BHSC, RoHS (M6 X 20)	186	
-	1	1	6-993111-6	PIN, SLOTTED SPRING 3.0 X 14.0	177	
-	1	1	8-22280-7	SPRING, COMPRESSION	176	
-	1	1	1752353-2	GUIDE PIN,HOLDDOWN	175	
-	1	1	1901680-2	GUIDE PIN,HOLDDOWN	174	
-	REF	REF	994970-2	COUNTER, MAGNETIC	164	
-	1	-	2119641-2	FEED CAM, AIR FEED	152	
-	1	1	2168083-8	SCR, SKT HD CAP, RoHS, M4 X 16	144	
-	-	1	2119653-2	FEED CAM, POST FEED	142	
-	1	1	2119655-6	APPLICATOR BASIC ASSEMBLY, EF	141	
-	1	1	1803518-1	RAM ASSEMBLY, EF PACIFIC	140	
-	1	1	2119955-2	ASSY, LUBRICATOR, END FEED	84	
-	1	1	455888-3	SPACER, CRIMPER	82	
-	1	1	1803607-4	DOCUMENTATION PACKAGE	71	
-	2	2	2-18032-2	SCR, SET, FLT PNT, M3 X 10.0	70	
-	1	1	2119740-1	TAG, IDENTIFICATION	67	
-	2	2	2168078-1	SCREW, DRIVE, RH, RoHS, 2 x .188	66	
-	1	1	1901681-1	HOLDDOWN, TERMINAL	65	
-	2	2	2168400-5	SHCS, LOW HEAD, RoHS, M4 X 20	64	
-	1	1	5-18022-5	SCR, HEX HD CAP, M4 X 6.0	59	
-	-	1	2063961-1	FEED FINGER	58	
-	3	3	2168400-4	SHCS, LOW HEAD, RoHS, M4 X 8	57	
-	2	2	1-2168083-0	SCR, SKT HD CAP, RoHS, M4 X 10	56	
-	2	2	5018030-1	NUT, HEX, REG, RoHS, M3	54	
-	2	2	986965-8	NUT, LOCK, HEX, TORQUE (M4)	53	
-	1	1	1-5018030-0	NUT, HEX, REG, RoHS, M3.5	52	
-	1	-	2063961-1	FEED FINGER	51	
-	1	1	1-1976055-2	STANDOFF, HOLD-DOWN	50	
-	1	2	18023-9	SCR, SKT HD CAP M4 X 6.0	49	
-	-	1	2119652-1	FEED CAM, PRE FEED	48	
-	1	1	1803602-1	SCR, BHSC, RoHS (M8 X 25)	41	
-	7	7	1-18028-2	WASHER, FLAT, REG M4	33	
-	2	2	2168083-9	SCR, SKT HD CAP, RoHS, M4 X 20	31	
-	2	2	2168083-2	SCR, SKT HD CAP, RoHS, M4 X 8.0	29	
-	1	1	240639-1	STRIPPER (MACHINING)	27	
-	2	2	1-2168083-5	SCR, SKT HD CAP, RoHS, M4 X 30	25	
-	1	1	1752371-3	PLATE, STRIP GUIDE	24	
-	1	1	240825-1	PLATE, STRIP HOLD DOWN	23	
-	2	2	2-22281-3	SPRING, COMPRESSION	22	
-	1	1	1803292-1	DRAG	20	
-	2	2	1901259-6	GUIDE, LOWER STRIP	18	
-	1	1	240641-2	SPACER	16	
-	1	1	1752360-1	SPACER,HOLD-DOWN	13	
-	1	1	240833-4	PLATE, REAR SHEAR	11	
-	-	-	-	-	10	
-	1	1	690482-4	PLATE, FRONT SHEAR	9	
-	1	1	1333219-6	ANVIL, COMBINATION	8	
-	1	1	1-2217206-2	BLADE, SLUG	7	
-	1	1	1-240641-6	SPACER	5	
-	1	1	238011-2	BLOCK, CRIMPER SPACER	4	
-	1	1	2-2119785-6	CRIMPER, INSULATION OVERLAP PREMIUM	3	
-	1	1	455888-7	SPACER, CRIMPER	2	
-	1	1	456408-9	CRIMPER, WIRE PREMIUM	1	
-	77	22	21	PART NO	DESCRIPTION	ITEM NO

DIMENSIONS:		TOLERANCES UNLESS OTHERWISE SPECIFIED:		DRAWING NO	
mm	0 PLC ±	1 PLC ±	2 PLC ±	3 PLC ±	4 PLC ±
mm	ANGLES	FINISH		WEIGHT	
MATERIAL				SCALE	

Customer Accessible Production Drawing

LOC	DIST	REVISIONS					
A	66	P	LTM	DESCRIPTION	DATE	DWN	APVD
		-		SEE SHEET 1		-	-

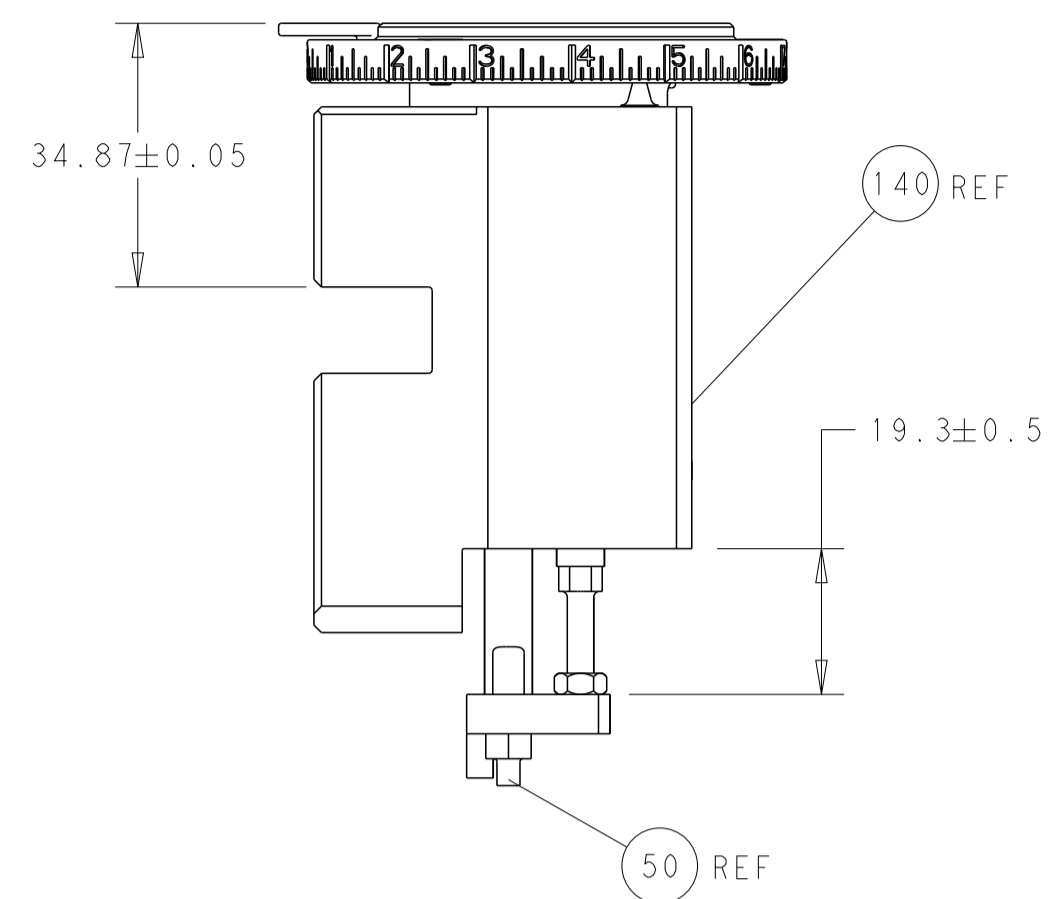

RAM AND HOLDDOWN SET-UP

FEED TYPE  
MECHANICAL

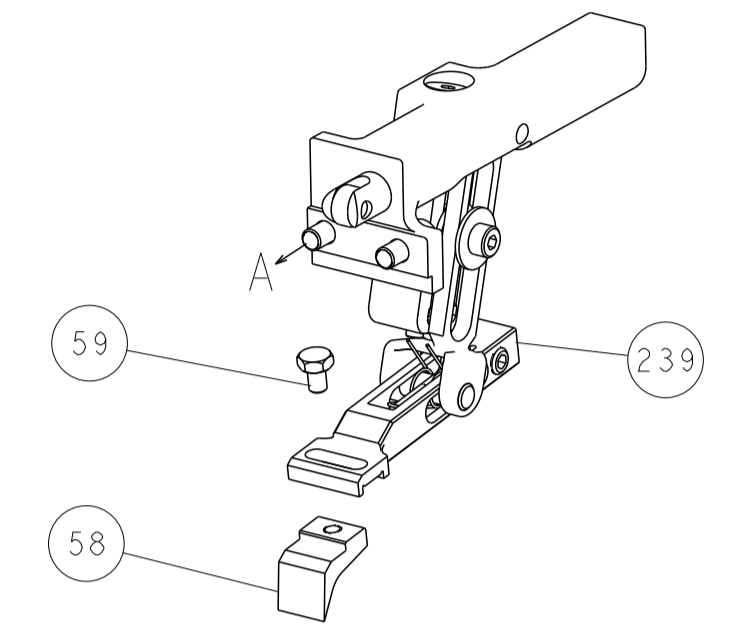

PNEUMATIC

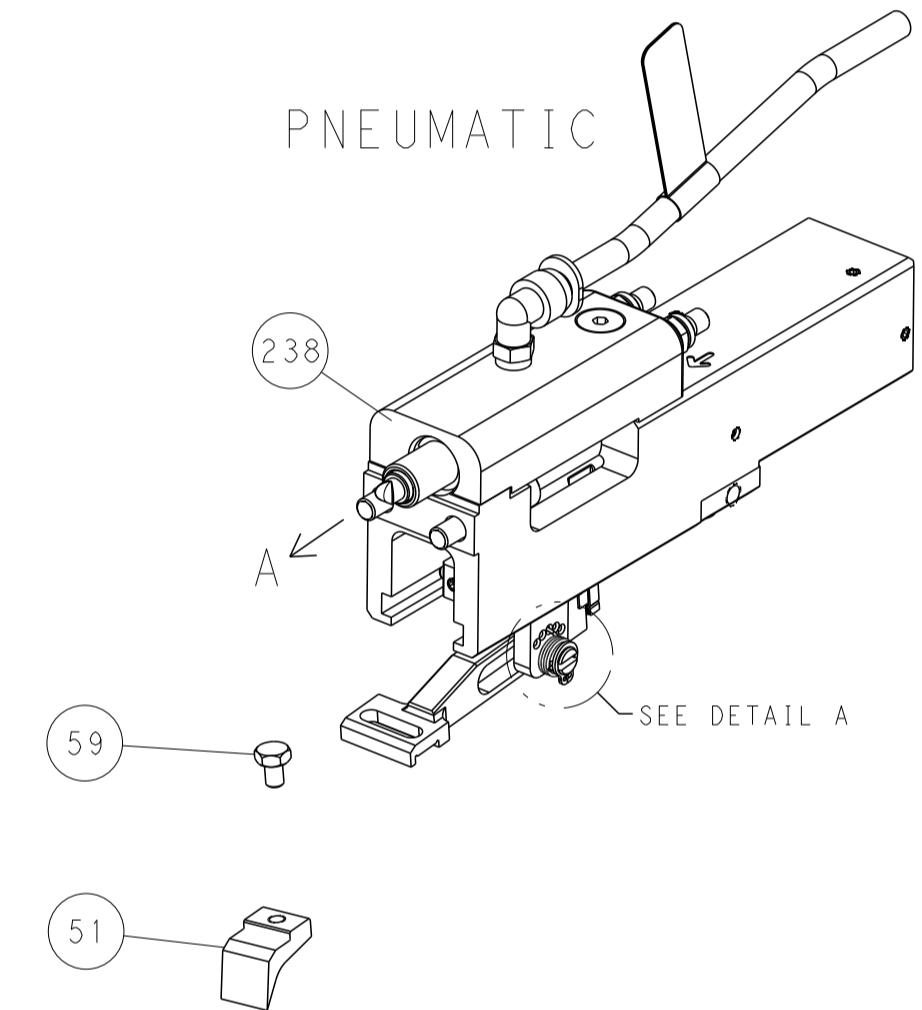

FEED SPRING  
SETTING POSITION

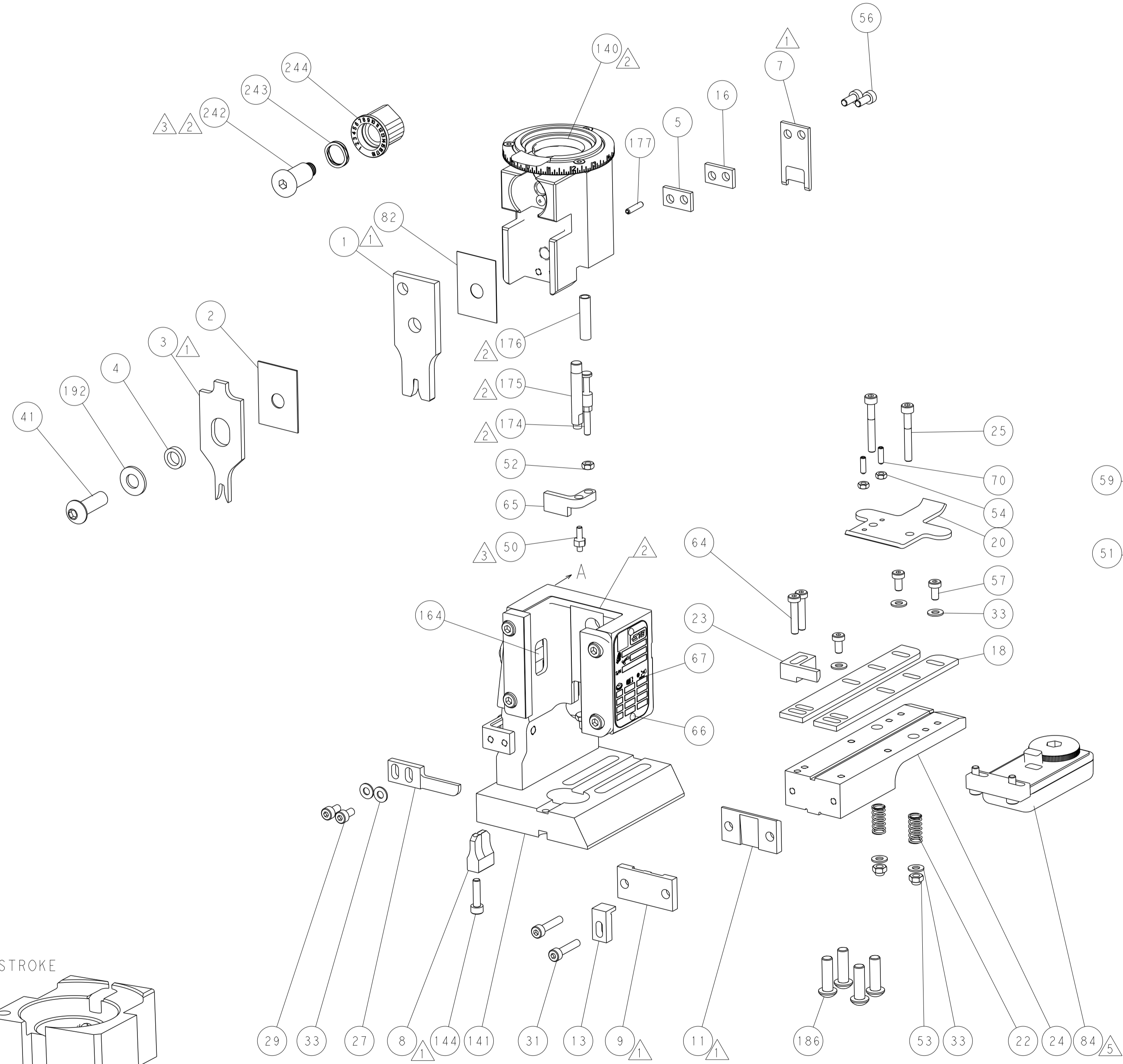
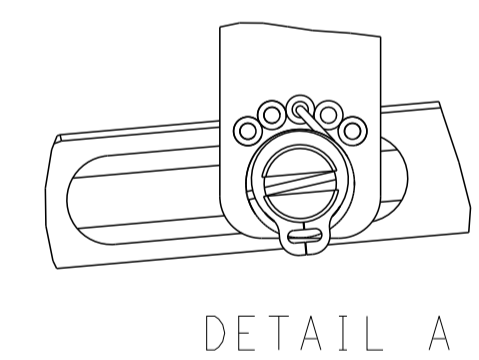

CAM POSITIONS

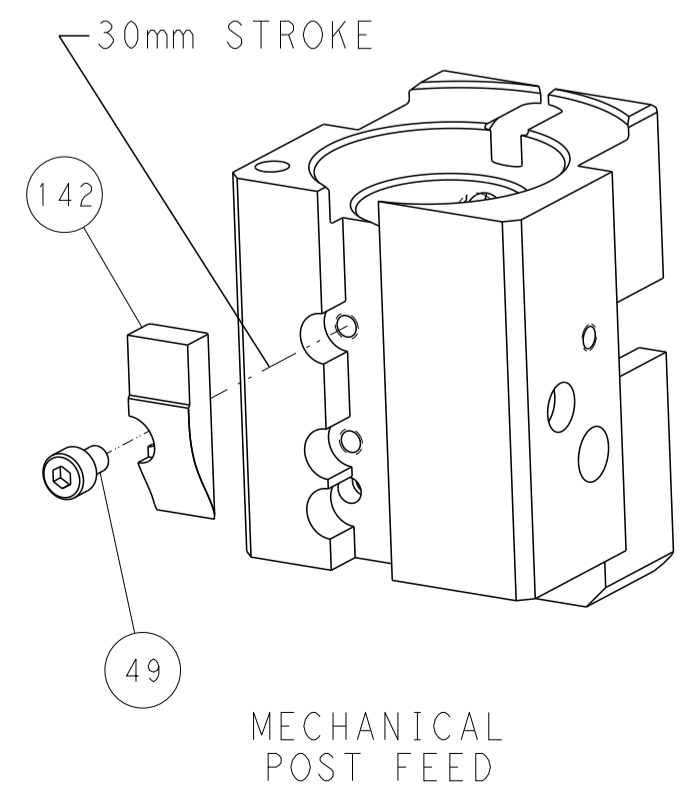

MECHANICAL  
POST FEED

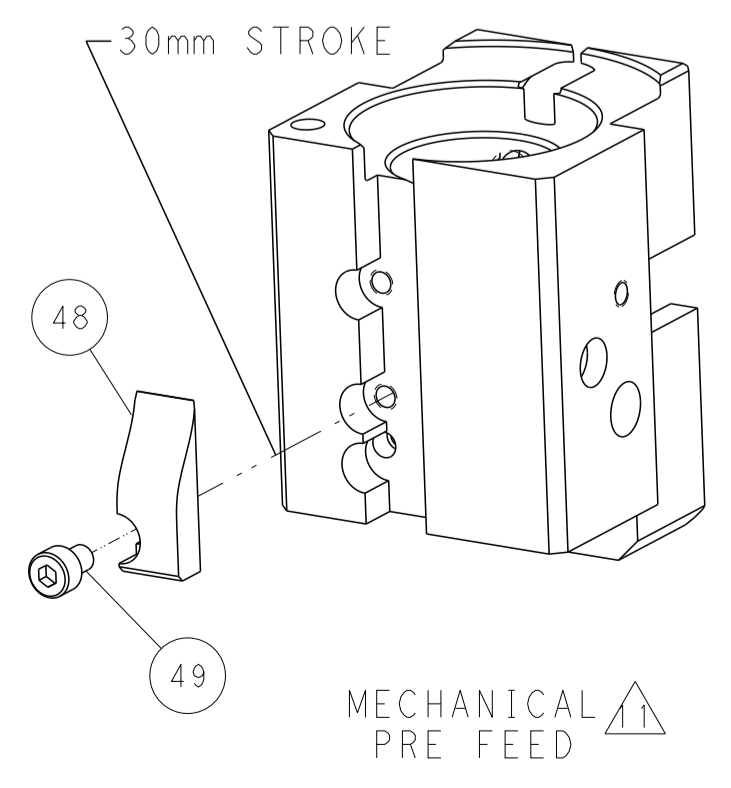

MECHANICAL  
PRE FEED

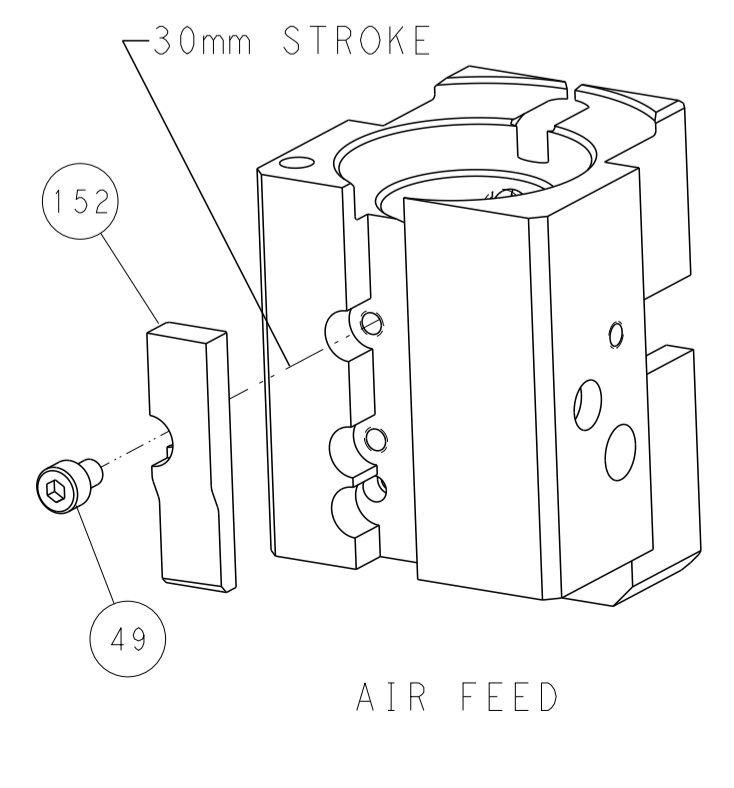

AIR FEED

PACIFIC VERSION  
 Shown on sheets 3 of 4 & 4 of 4  
 (Atlantic version shown on sheets 1 of 4 & 2 of 4)

DIMENSIONS:		TOLERANCES UNLESS OTHERWISE SPECIFIED:		DWN C. CHEN 10OCT2012		STE TE Connectivity	
mm	0 PLC ±	1 PLC ±	2 PLC ±	3 PLC ±	4 PLC ±	Harrisburg, PA 17105-3608	
MATERIAL:	FINISH:	WEIGHT:	SCALE:	APVD: J. CRUZ 10OCT2012	NAME:	Ocean End Feed Applicator	
Customer Accessible Production Drawing				SCALE: 1:1	SHEET 4 OF 4	REV K	