

W7500x Data Sheet

Version 1.1.0



<http://www.wiznet.co.kr>

Table of Contents

Table of Contents	1
List of table	4
List of figures	5
1 Introduction	6
2 Description	7
3 Functional overview	9
3.1 ARM®-Cortex®-M0 core with embedded Flash and SRAM	9
3.2 Memories	9
3.3 Boot modes	9
3.4 System configuration controller (SYSCFG)	10
3.5 Power management	10
3.5.1 Power supply schemes	10
3.5.2 Low-power modes	10
3.6 Clocks and startup	11
3.6.1 External Oscillator Clock	11
3.6.2 RC oscillator clock	12
3.6.3 PLL	12
3.6.4 Generated clock	12
3.7 Interrupts and events	13
3.7.1 Nested vectored interrupt controller (NVIC)	13
3.7.2 Event controller	13
3.8 Tcp/ip offload engine (TOE)	13
3.9 General-purpose inputs/outputs (GPIOs)	14
3.10 Pad controller (PADCON)	14
3.11 Alternative function controller (AFC)	16
3.12 External interrupt (EXTI)	18
3.13 Direct memory access controller (DMA)	19
3.14 Timers and watchdogs	19
3.14.1 System tick timer	19
3.14.2 Pulse-Width Modulation (PWM)	20
3.14.3 Dual timers	20
3.14.4 Watchdog timer	20
3.15 Real-time clock (RTC)	21
3.15.1 RTC clock	21
3.15.2 RTC interrupt	21
3.16 Universal asynchronous receiver/transmitter (UART)	21
3.17 Synchronous Serial Port (SSP)	22

3.18	Random number generator (RNG)	22
4	Pinout and descriptions.....	23
4.1	Pin layout.....	23
4.2	Pin descriptions.....	24
4.2.1	W7500 Pin Description	24
4.2.2	W7500P Pin Description	27
5	Electrical characteristics	30
5.1	Absolute maximum ratings.....	30
5.2	Voltage Characteristics.....	30
5.3	Current Characteristics.....	30
5.4	Thermal Characteristics.....	31
5.5	Operating conditions	31
5.5.1	General Operating Conditions.....	31
5.6	Supply Current Characteristics.....	32
5.7	I/O PAD Characteristics.....	33
5.8	Electrical Sensitivity Characteristics	33
5.9	Reset & PLL Characteristics.....	34
5.10	SSP Interface Characteristics	35
6	Package Information.....	36
6.1	Package dimension information	36
	Document History Information.....	37

List of table

Table 1. W7500/W7500P family device features and peripheral counts	7
Table 2 operation of mode selection	9
Table 3 W7500x sleep mode summary	10
Table 4 functional description table	16
Table 5 Summary of the DMA requests for each channel.....	19
Table 6. Pin Type Notation	24
Table 7 W7500 Pin Description	24
Table 8. W7500P Pin Description	27
Table 9 Voltage characteristics	30
Table 10 Current characteristics	30
Table 11 Thermal Charateristics.....	31
Table 12 General operating conditions	31
Table 13 Normal operation supply current	32
Table 14 Sleep mode supply current	32
Table 15 Deep sleep mode supply current	32
Table 16 DC specification of PAD	33
Table 17 Flash memory Reliability Characteristics.....	33
Table 18 Electrostatic discharge (ESD)	33
Table 19 Static latch-up	33
Table 20 PLL electrical characteristics	34
Table 22 SSP characteristics.....	35

List of figures

Figure 1. W7500x System Architecture	8
Figure 2. CRG block diagram.....	11
Figure 3 Typical application with an 8 MHz crystal	12
Figure 4. function schematic of digital I/O pad.....	14
Figure 5. function schematic of digital/analog mux IO pad	14
Figure 6. External Interrupt diagram	18
Figure 7 W7500 pin layout.....	23
Figure 8 W7500P pin layout	23
Figure 9 Power Down operation Timing Sequence for PLL	34
Figure 11. SSP Timing for SPI Frame format, with SPH =1	35
Figure 12. Package Dimension Information	36

1 Introduction

This datasheet provides the ordering information and mechanical device characteristics of the W7500/W7500P microcontrollers.

This document should be read in conjunction with the W7500x reference manual (RM). The reference manual is available from the WIZnet website www.wizwiki.net.

For information on the ARM® Cortex®-M0 core, please refer to the Cortex®-M0 Technical Reference Manual, available from the www.arm.com website.

2 Description

The W7500x microcontrollers incorporate the high-performance ARM® Cortex®-M0 32-bit RISC core operating at a 48 MHz frequency, high-speed embedded memories (128 Kbytes of Flash memory and 16Kbytes of SRAM), and TCP/IP offload engine, an extensive range of enhanced peripherals and I/Os. All devices offer standard communication interfaces (two SPIs and three UARTs), 4 general-purpose timers and eight advanced control PWM timer.

The W7500x microcontrollers operate in the 0 to +70 °C temperature range from a 2.7 to 3.6V power supply. A comprehensive set of power-saving modes allows the design of low-power applications.

The W7500x microcontrollers include devices in two different packages from include PHY and non-include PHY.

These features make the W7500x microcontrollers suitable for a wide range of IoT applications such as application control and user interfaces.

Table 1. W7500/W7500P family device features and peripheral counts

Peripherals		W7500	W7500P
Flash memory in Kbytes		128	
SRAM in Kbytes		16	
Timers	RTC	1	
	Watch Dog	1	
	Dual Timer	2	
	PWM	up to 8	
Comm	UART	up to 3	
	SPI	up to 2	
	TCP/IP Socket	8	
Internal PHY		No	Yes
GPIOs		53	34
RNG		1	
DMA channel		6	
CPU frequency		48MHz	
Operating voltage		2.7 to 3.6V	
Operating temperatures		Ambient temp : -40 to 85°C	Ambient temp : 0 to 70°C
		Junction temp : -30 to 105°C	Junction temp : 0 to 105°C
Package		LQFP64	

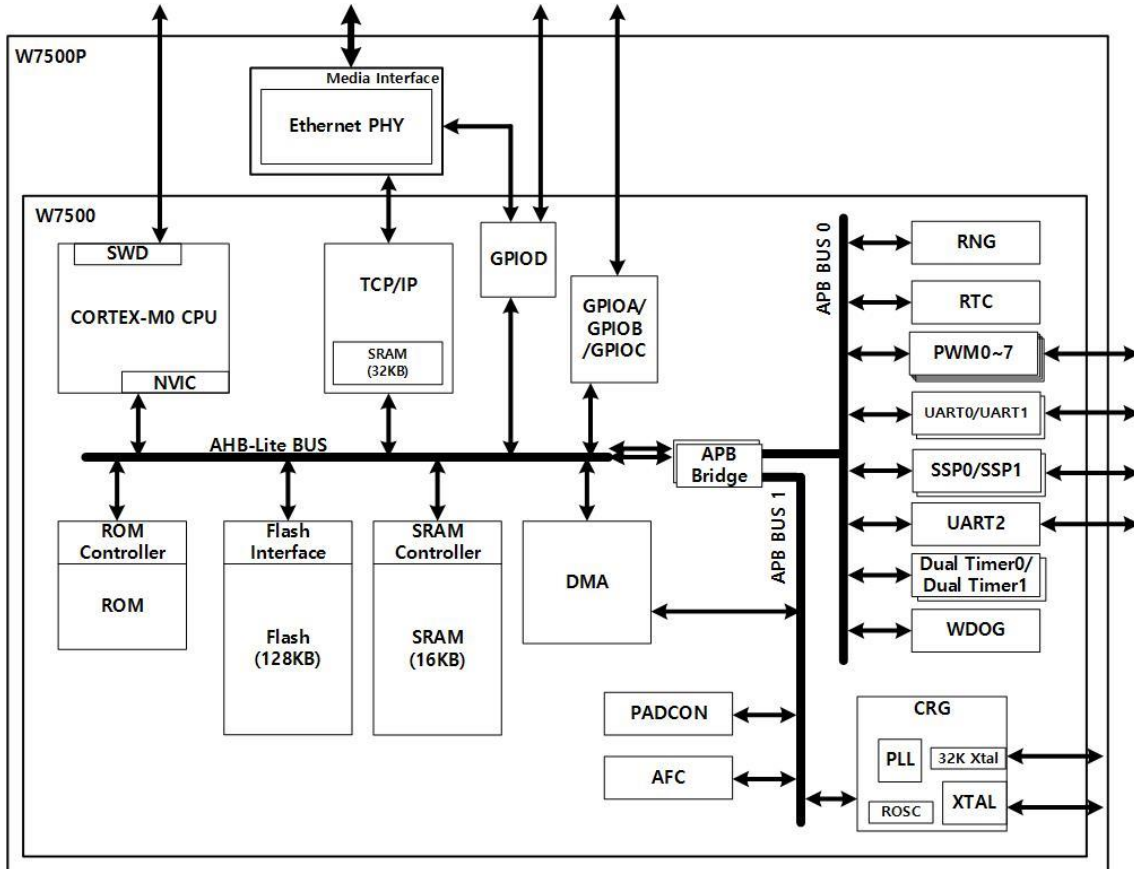

Figure 1. W7500x System Architecture

3 Functional overview

3.1 ARM®-Cortex®-M0 core with embedded Flash and SRAM

The ARM® Cortex®-M0 processor is the latest generation of ARM processors for embedded systems. It has been developed to provide a low-cost platform that meets the needs of MCU implementation, with a reduced pin count and low-power consumption, while delivering outstanding computational performance and an advanced system response to interrupts.

The ARM® Cortex®-M0 32-bit RISC processor features exceptional code-efficiency, delivering the high-performance expected from an ARM core in the memory size usually associated with 8- and 16-bit devices.

The W7500x family has an embedded ARM core and is therefore compatible with all ARM tools and software.

- Figure 1 shows the general block diagram of the W7500x family.

3.2 Memories

Program memory, data memory, registers and I/O ports are organized within the same linear 4-Gbyte address space.

The bytes are coded in memory in Little Endian format. The lowest numbered byte in a word is considered the word's least significant byte and the highest numbered byte the most significant.

3.3 Boot modes

W7500x has three different boot modes that can be selected through the BOOT pin as shown in Table 2.

Table 2 operation of mode selection

BOOT pin	Mode	Aliasing
0	APP	User code execute in Main Flash memory.
1	ISP	In this mode, W7500x can support ISP function in order to control flash using serial interface.

3.4 System configuration controller (SYSCFG)

Main purposes of the system configuration controller are the following

- The ability to enable an automatic reset if the system locks up
- Information about the cause of the last reset

3.5 Power management

3.5.1 Power supply schemes

W7500x embeds a voltage regulator in order to supply the internal 1.5V digital power domain. Require a 2.7V - 3.6V operating supply voltage (VDD).

3.5.2 Low-power modes

W7500x is in RUN mode after a system or power reset. There are two low power modes to save power when the CPU does not need to be kept running. These modes are useful for instances like when the CPU is waiting for an external interrupt. Please note that there is no power-off mode for W7500x.

The device features two low-power modes:

- Sleep mode
- Deep Sleep mode

Additionally, the power consumption can be reducing by following method:

User can slow down the system clocks

User can gate the clocks to the peripherals when they are unused.

Sleep mode / Deep sleep mode

W7500x has two kinds of sleep modes. One is Sleep mode and the other is Deep sleep mode. Two of them are almost the same except the clock gated peripherals kinds. Table 3 shows the Sleep mode summary.

Table 3 W7500x sleep mode summary

Mode	Entry	Wakeup	Effect on clocks
Sleep mode	DEEPSLEEP = 0 Enable WFI	Any interrupt	CPU clock OFF APB Bus Clock ON AHB Bus clock ON Memory clocks ON
	DEEPSLEEP = 0 Enable WFE	Wakeup event	
Deep Sleep mode	DEEPSLEEP = 1 Enable WFI	Any interrupt	CPU clock OFF APB Bus Clock OFF AHB Bus clock OFF Memory clocks OFF
	DEEPSLEEP = 1 Enable WFE	Wakeup event	

3.6 Clocks and startup

Two clock sources can be used to drive the system clock.

- External oscillator clock (8MHz ~ 24MHz) (OCLK)
- Internal 8MHz RC oscillator clock (RCLK)

One additional clock source

- 32.768KHz low speed external crystal which derives the real time clock.

There is a PLL

One PLL is integrated

- Input clock range is from 8MHz to 24MHz
- Frequency can be generated by M/N/OD registers. (refer register description)
- Bypass option enabled

There are many generated clocks for independent operating with system clock

- System clock (FCLK)
- SSP0, SSP1 clock (SSPCLK)
- UART0, UART1 clock (UARTCLK)
- Two Timer clocks (TIMCLK0, TIMCLK1)
- 8ea PWM clocks (PWMCLK0 - PWMCLK7)
- Real time clock (RTCCLK)
- WDOG clock (WDOGCLK)
- Random number generator clock (RNGCLK)

RNGCLK have only one source (pll output) and no prescaler

Some of the generated clocks turn off automatically when CPU enters sleep mode.

- RNGCLK

Generate two Hardware TCPIP Clocks (MII_RXC, MII_TXC) are from external PADs.

Hardware TCPIP Clocks can be gated by register control.

All clocks generated from CRG can be monitored.

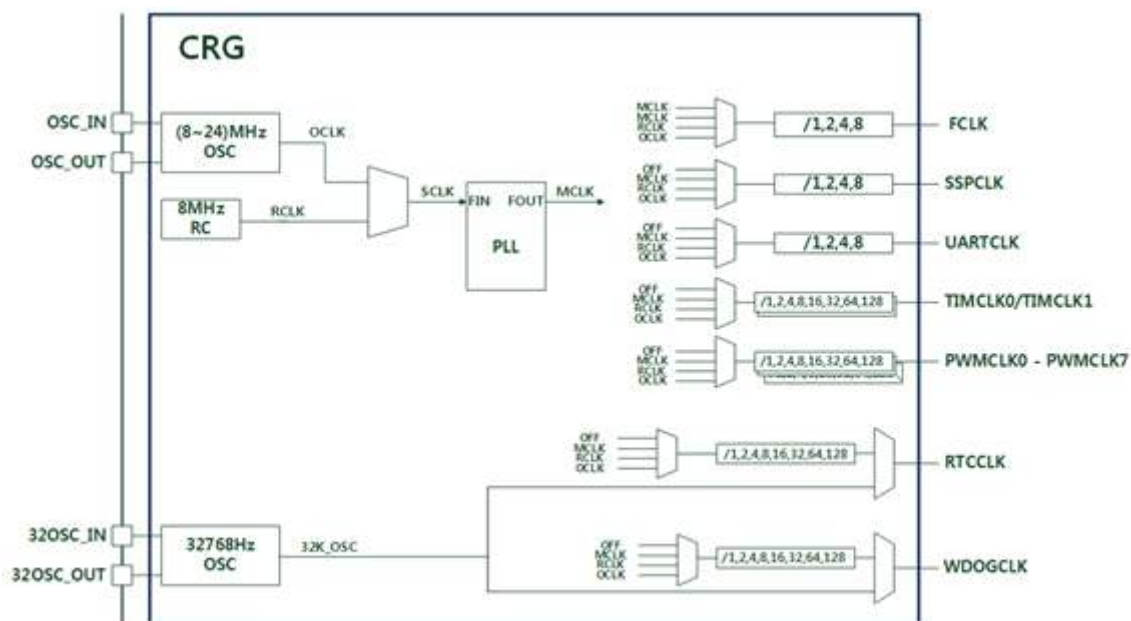

Figure 2. CRG block diagram

3.6.1 External Oscillator Clock

The External oscillator clock (OCLK) can be supplied with a 8 to 24 MHz crystal/ceramic resonator oscillator. In the Typical application, Figure 3, R_f must be inserted in External

oscillator clock circuit. In W7500x, there is no supported R_F for External oscillator clock (see Figure 3).

For C_{Load1} and C_{Load2} , it is recommended to use external ceramic capacitors in the 5 pF to 25 pF range (typ.) and are usually the same size, designed for application, and selected to match the requirements of the crystal or resonator (see Figure 3).

Refer to the crystal resonator manufacturer for more details on the resonator characteristics (frequency, package, accuracy).

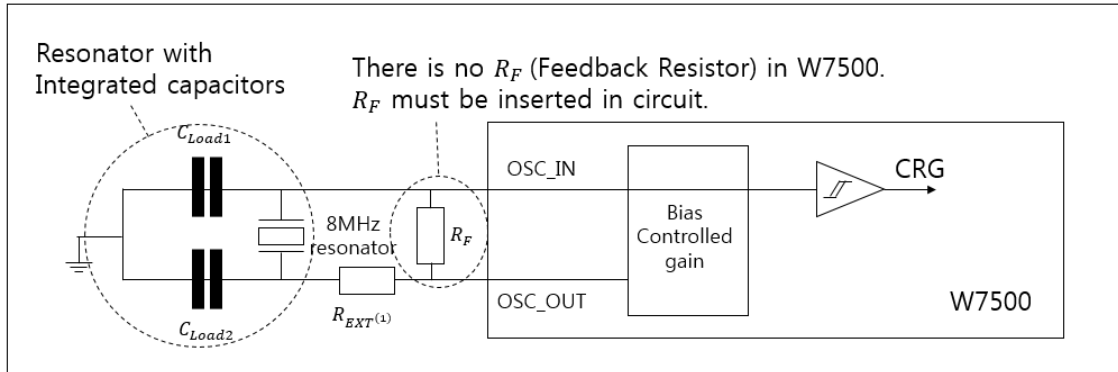

¹ R_{EXT} value depends on the crystal characteristics

Figure 3 Typical application with an 8 MHz crystal

3.6.2 RC oscillator clock

RC oscillator clock (RCLK) signal is generated from an internal 8MHz RC oscillator. RC oscillator has the advantage of providing a clock source at low cost (no external components). However the RC oscillator is less accurate than the external crystal or ceramic resonator.

Accuracy : 1% at $T_A = 25^\circ\text{C}$ (User don't need to calibration)

3.6.3 PLL

The internal PLL can be used to multiply the External Oscillator Clock (OCLK) or RC Oscillator Clock (RCLK). PLL input can be selected by register.

PLL output clock can be generated by following the equations below.

- $F_{OUT} = F_{IN} \times M / N \times 1 / OD$

-

Where:

- $M = M[5] \times 2^5 + M[4] \times 2^4 + M[3] \times 2^3 + M[2] \times 2^2 + M[1] \times 2 + M[0] \times 1$
- $N = N[5] \times 2^5 + N[4] \times 2^4 + N[3] \times 2^3 + N[2] \times 2^2 + N[1] \times 2 + N[0] \times 1$
- $OD = 2^{(2 \times OD[1])} \times 2^{(1 \times OD[0])}$

3.6.4 Generated clock

Each generated clock source can be selected among 3 clock source as independent by each clock source select register.

- PLL output clock (MCLK)
- Internal 8MHz RC oscillator clock (RCLK)
- External oscillator clock (8MHz ~ 24MHz) (OCLK)
- Each generated clock has own prescaler which can be selected individually by each prescale value register.
- FCLK, SSPCLK, UARTCLK : 1/1, 1/2, 1/4, 1/8

¹ R_{EXT} value depends on the crystal characteristics

- TIMCLK0, TIMCLK1, PWMCLK0 - PWMCLK7, RTCCLK, WDOGCLK : 1/1, 1/2, 1/4, 1/8, 1/16, 1/32, 1/64, 1/128

3.7 Interrupts and events

3.7.1 Nested vectored interrupt controller (NVIC)

The W7500x family embeds a nested vectored interrupt controller able to handle up to 32 maskable interrupt channels (not including the 16 interrupt lines of Cortex®-M0) and 4 priority levels.

- Closely coupled NVIC gives low latency interrupt processing
- Interrupt entry vector table address passed directly to the core
- Closely coupled NVIC core interface
- Allows early processing of interrupts
- Processing of late arriving higher priority interrupts
- Support for tail-chaining
- Processor state automatically saved
- Interrupt entry restored on interrupt exit with no instruction overhead

This hardware block provides flexible interrupt management features with minimal interrupt latency.

3.7.2 Event controller

The W7500x family is able to handle internal events in order to wake up the core(WFE). The wakeup event can be generated by

- When after DMA process finished (DMA_DONE)

3.8 Tcp/ip offload engine (TOE)

The TCP/IP Core Offload Engine (TOE) is a Hardwired TCP/IP embedded Ethernet controller that provides easier Internet connection to embedded systems. TOE enables users to have Internet connectivity in their applications by using the TCP/IP stack.

WIZnet's Hardwired TCP/IP is the market-proven technology that supports TCP, UDP, IPv4, ICMP, ARP, IGMP, and PPPoE protocols. TOE embeds the 32Kbyte internal memory buffer for the Ethernet packet processing. Using TOE allows users to implement the Ethernet application by adding the simple socket program. It's faster and easier than using any other Embedded Ethernet solutions. 8 independent hardware sockets can be used simultaneously.

TOE also provides WOL (Wake on LAN) to reduce power consumption of the system.

- Supports Hardwired TCP/IP Protocols : TCP, UDP, ICMP, IPv4, ARP, IGMP, PPPoE
- Supports 8 independent sockets simultaneously
- Supports Power down mode
- Supports Wake on LAN over UDP
- Internal 32Kbytes Memory for TX/RX Buffers
- Not supports IP Fragmentation

3.9 General-purpose inputs/outputs (GPIOs)

The GPIO(General-Purpose I/O Port) is composed of three physical GPIO blocks, each corresponding to an individual GPIO port(PORT A, PORT B and PORT C). The GPIO supports up to 34 programmable input/output pins, depending on the peripherals being used.

- The GPIO peripheral consists the following features.
- GPIO_DATAOUT can SET/CLEAR by the SET register and CLEAR register. (1 for set and 0 for clear)
- Mask registers allow treating sets of port bits as a group leaving other bits unchanged.
- Up to 34 GPIOs depending on configuration
- Programmable control for GPIO interrupts
- Interrupt generation masking
- Edge-triggered on rising, falling, ~~or both~~

Refer to 'Reference Manual' for more details about each register.

3.10 Pad controller (PADCON)

Pads of W7500x are controllable. User can control pad's characteristic.

W7500x has digital I/O pads and digital/analog mux I/O pads

Controllable characteristics of pads are pull-up, pull-down, driving strength, input enable, and CMOS/Schmitt trigger input buffer

Each pad can be controlled individually by register.

Figure 4 shows the function schematic of digital I/O pad of W7500x.

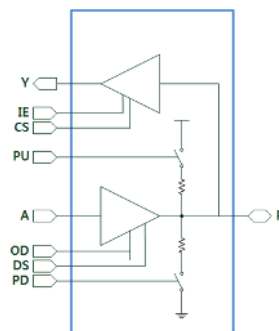

Figure 4. function schematic of digital I/O pad

Figure 5 shows the function schematic of digital/analog mux IO pad of W7500x

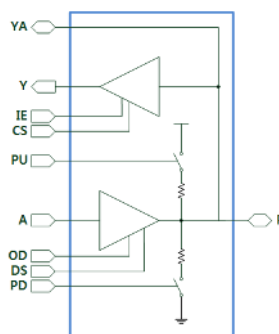

Figure 5. function schematic of digital/analog mux IO pad

Initials of Pad diagram is same as below.

- P - PAD
- A - Digital Output
- YA - Analog Input
- Y - Digital Input
- IE - Input buffer enable

Condition		A	Y	P
Input buffer enable (IE = 1)	Output mode	OUT	OUT	OUT
	Input mode	No use	IN	IN
Input buffer disable (IE = 0)	Output mode	OUT	Low (0)	OUT
	Input mode	No use	IN	IN

- CS - CMOS/Schmitt trigger input buffer select
- PU - Pull-up enable
- PD - Pull-down enable
- OD - Open Drain
- DS - Driving strength select

Condition		Rise/Fall Time (nSec)		Propagation Delay (nSec)	
Driving Strength	Capacitance loading	Min	Max	Min	Max
Low (DS = 1)	25pF	4	18	7	27
	100pF	11	53	11	44
High (DS = 0)	25pF	1	8	4	16
	100pF	4	23	7	24

User can set pad condition with IE, CS, PU/PD, OD, DS by register. And pads are can be controlled individually.

3.11 Alternative function controller (AFC)

Each functional PADS have several functions.
Users can select a function in Alternate Function Controller block.

Each functional pad has 2 ~ 4 functions.
Pads can be selected by each registers individually.
Each pad can be used as an external interrupt source.

Table 4 shows the function table of each functional pad.

Table 4 functional description table

Pins		Pin name	Alternate function			
W7500	W7500P		default	2nd	3rd	4th
29	27	PA_00	GPIOA_0	GPIOA_0	PWM6/CAP6	
30	28	PA_01	GPIOA_1	GPIOA_1	PWM7/CAP7	
31	29	PA_02	GPIOA_2	GPIOA_2	CLKOUT	
49	30	PA_03	SWCLK	GPIOA_3		PWM0/CAP0
50	31	PA_04	SWDIO	GPIOA_4		PWM1/CAP1
33	19	PA_05	SSEL0	GPIOA_5	SCL1	PWM2/CAP2
34	20	PA_06	SCLK0	GPIOA_6	SDA1	PWM3/CAP3
35	21	PA_07	MISO0	GPIOA_7	U_CTS1	PWM4/CAP4
36	22	PA_08	MOSIO	GPIOA_8	U_RTS1	PWM5/CAP5
37	23	PA_09	SCL0	GPIOA_9	U_TXD1	PWM6/CAP6
38	24	PA_10	SDA0	GPIOA_10	U_RXD1	PWM7/CAP7
40	41	PA_11	U_CTS0	GPIOA_11	SSEL1	
41	42	PA_12	U_RTS0	GPIOA_12	SCLK1	
42	43	PA_13	U_TXD0	GPIOA_13	MISO1	
43	44	PA_14	U_RXD0	GPIOA_14	MOSI1	
44	-	PA_15	GPIOA_15	GPIOA_15		
45	45	PB_00	SSEL1	GPIOB_0	U_CTS0	
46	46	PB_01	SCLK1	GPIOB_1	U_RTS0	
47	47	PB_02	MISO1	GPIOB_2	U_TXD0	
48	48	PB_03	MOSI1	GPIOB_3	U_RXD0	
24	-	PB_04	TXEN	GPIOB_4		
25	-	PB_05	COL	GPIOB_5		
16	15	PB_06	RXD3 ¹⁾ / DUP ²⁾	GPIOB_6 ¹⁾		
17	-	PB_07	RXCLK	GPIOB_7		

18	-	PB_08	DUP	GPIOB_8		
19	-	PB_09	TXCLK	GPIOB_9		
20	-	PB_10	TXD0	GPIOB_10		
21	-	PB_11	TXD1	GPIOB_11		
22	-	PB_12	TXD2	GPIOB_12		
23	-	PB_13	TXD3	GPIOB_13		
26	-	PB_14	GPIOB_14	GPIOB_14		
27	-	PB_15	GPIOB_15	GPIOB_15		
53	53	PC_00	U_CTS1	GPIOC_0	PWM0/CAP0	
54	54	PC_01	U_RTS1	GPIOC_1	PWM1/CAP1 ¹⁾	
55	55	PC_02	U_TXD1	GPIOC_2	PWM2/CAP2	
56	56	PC_03	U_RXD1	GPIOC_3	PWM3/CAP3 ¹⁾	
57	57	PC_04	SCL1	GPIOC_4	PWM4/CAP4	
58	58	PC_05	SDA1	GPIOC_5	PWM5/CAP5	
51	11	PC_06	GPIOC_6	GPIOC_6	U_TXD2	
52	-	PC_07	GPIOC_7	GPIOC_7	U_RXD2	
1	1	PC_08	PWM0/CAP0	GPIOC_8	SCL0	NA
2	2	PC_09	PWM1/CAP1	GPIOC_9	SDA0	NA
3	3	PC_10	U_TXD2	GPIOC_10	PWM2/CAP2	NA
4	4	PC_11	U_RXD2	GPIOC_11	PWM3/CAP3	NA
5	5	PC_12	NA	GPIOC_12	SSEL0	NA
6	6	PC_13	NA	GPIOC_13	SCLK0	NA
7	7	PC_14	NA	GPIOC_14	MISO0	NA
8	8	PC_15	NA	GPIOC_15	MOSIO	NA
11	-	PD_00	CRS	GPIOD_0		
12	-	PD_01	RXDV	GPIOD_1		
13	-	PD_02	RXD0	GPIOD_2		
14	-	PD_03	RXD1	GPIOD_3		
15	-	PD_04	RXD2	GPIOD_4		

1) Only W7500

2) Only W7500P

3.12 External interrupt (EXTI)

Each functional pads are connected to the external interrupt(EXTINT) source.

- All functional pads can be used as an external interrupt source regardless of any set of pad function.
- External Interrupt controller has the following functions and can be controlled by registers.
- Interrupt mask (enable or disable, default : disable)
- Interrupt polarity (rising or falling, default : rising)

All pads are connected to the control register individually. (External interrupt mask register and External Interrupt polarity register)

External interrupt working as following expression:

- Each pad interrupt = Interrupt mask & (Interrupt polarity ^ Pad input)
- EXTINT = any Each pad interrupt

Figure 6 shows the External Interrupt diagram.

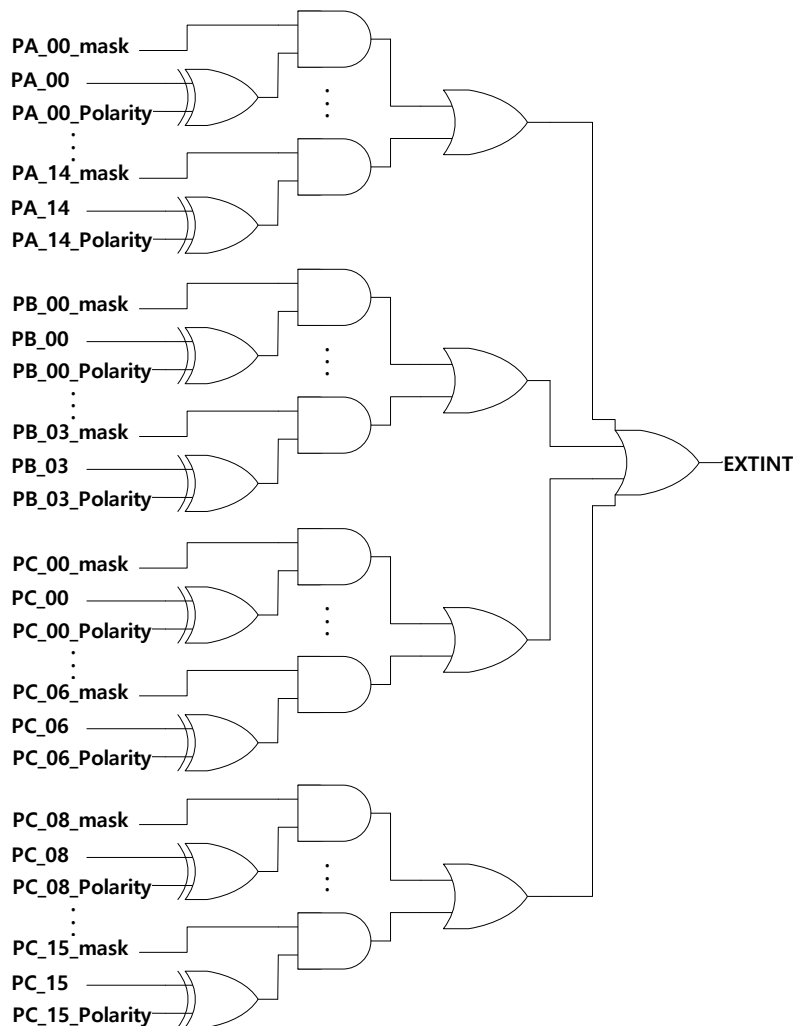

Figure 6. External Interrupt diagram

3.13 Direct memory access controller (DMA)

Direct memory access (DMA) is used in order to provide high-speed data transfer between peripherals and memory as well as memory to memory. Data can be quickly moved by DMA without any CPU actions. This keeps CPU resources free for other operations.

The DMA controller has up to 6 channels in total, each dedicated to managing memory access requests from one or more peripherals. It has an arbiter for handling the priority between DMA requests. For more details, refer to “PrimeCell® μ DMA Controller (PL230)” from the Technical Reference Manual

- 6 channels
- Each channel is connected to dedicated hardware DMA requests and software trigger is also supported on each channel.
- Priorities between requests from the DMA channels are software programmable (2 levels consisting of high, default)
- Memory-to-memory transfer (software request only)
- TCP/IP-to-memory transfer (software request only)
- SPI/UART-to-memory transfer (hardware request and software request)
- Access to Flash, SRAM, APB and AHB peripherals as source and destination

DMA request mapping

The hardware requests from the peripherals (UART0, UART1, SSP0, SSP1) are simply connected to the DMA. Refer to Table 5 which lists the DMA requests for each channel.

Table 5 Summary of the DMA requests for each channel

	Channel 1	Channel 2	Channel 3	Channel 4	Channel 5	Channel 6
Hardware Request	SSP0_TX SSP0_RX	SSP1_TX SSP1_RX	UART0_TX UART0_RX	UART1_TX UART1_RX	NONE	NONE
Software Request ⁽¹⁾	Support	Support	Support	Support	Support	Support

Software request is the only way to use DMA for memory-to-memory or TCP/IP-to-memory.

3.14 Timers and watchdogs

3.14.1 System tick timer

System tick timer(SysTick) is part of the ARM Cortex-M0 core

- Simple 24bit timer.
- Clocked internally by the system clock or the system clock/2.

The SysTick timer is an integral part of Cortex-M0. The SysTick timer is intended to generate a fixed 10 millisecond interrupt for use by an operating system or other system management software.

Since the SysTick timer is a part of the Cortex-M0, it facilitates porting of software by providing a standard timer that is available on Cortex-M0 based devices.

The SysTick timer can be used for :

- An RTOS tick timer which fires at a programmable rate (for example 100 Hz) and invokes a SysTick routine.
- A high-speed alarm timer using the core clock.
- A simple counter. Software can use this to measure time to completion and time used.

- An internal clock source control based on missing/meeting durations. The COUNTFLAG bit-field in the control and status register can be used to determine if an action completed within a set duration, as part of a dynamic clock management control loop.

3.14.2 Pulse-Width Modulation (PWM)

The PWM consists a 8-channel 32-bit Timer/Counter driven by a programmable prescaler. The function of the PWM is based on the basic Timer. Each timer and counter runs independently.

The PWM can be used to control the width of the pulse, formally the pulse duration, to generate output waveform or to count the counter triggered by external input.

- Counter or Timer operation can use the peripheral clock, external clock source, or one of the capture inputs as the clock source.
- Eight independent 32-bit Timer/Counter driven by a programmable 6 bits prescaler runs as the PWM or standard timer if the PWM mode is not enabled.
- Eight PWM output waveforms.
- Each of Timer/Counter can have different or same clock source.
- Counter or timer operation.
- Eight capture registers that can take the timer value when an external input signal. A capture event can generate an interrupt signal optionally.
- 32-bit match register and limit register.

3.14.3 Dual timers

The dual timer consists two programmable 32-bit or 16-bit Free-running counters(FRCs) that can generate interrupts when they reach 0. There are two dual timers and 4 FRCs. One dual timers has one interrupt handler, resulting in two interrupts of timers. Also one dual timer has one clock but two clock enable signals. Users can select one repetition modes one-shot or wrapping mode, and wrapping mode consists free-running and periodic mode. Two FRCs are one set so two FRCs has one clock, reset, and interrupt but each FRC has an individual clock enable.

- One dual timer has two Free-Running Counters(FRCs).
- One dual timer has one interrupt handler and one clock.
- One dual timer has two clock enable signals.
- There are 2 dual timers.
- A 32-bit or a 16-bit down counter.
- One of the following repetition modes: one-shot and wrapping mode.
- One of the following wrapping modes: Free-running and periodic mode.
- There is a prescaler that can divide down the clock rate by 1, 16, or 256.

3.14.4 Watchdog timer

The watchdog is based on a 32-bit down-counter that is initialized from the Reload Register, WDTLoad. The watchdog generates a regular interrupt depending on a programmed value. The counter decreases by one on each positive clock edge of watchdog clock.

The watchdog monitors the interrupt and asserts a reset request signal when the counter reaches 0 and the counter is stopped. On the next enabled watchdog clock edge, the counter is reloaded from the WDTLoad Register and the countdown sequence continues. The watchdog reasserts the reset signal if the interrupt is not cleared by the time the counter next reaches 0.

The watchdog applies a reset to a system in the event of a software failure to provide a way to recover from software crashes. Users can enable or disable the watchdog unit as required.

- 32-bit down counter.

- Internally resets chip if not periodically reloaded.
- The watchdog timer has lock register to prevent rogue software from disabling the watchdog timer functionality.
- The watchdog timer clock(WDTCLK) and system clock(PCLK) are synchronous.

3.15 Real-time clock (RTC)

The real-time clock (RTC) is an independent BCD timer/counter. The RTC provides a timer-of-day clock/calendar with programmable alarm interrupt.

Calendar with year, month, day, weekday, hours, minutes, and seconds
Programmable alarm with interrupt function

3.15.1 RTC clock

RTC Clock (RTCCLK) can be selected among several clocks (32768Hz oscillator, MCLK, RCLK, OCLK). Please refer to the Clock Reset Generator chapter for configuring the clock. If the 32768Hz oscillator clock is used, the divider generates 1 Hz clock internally. If the DIVRST (Bit[1] of RTC Control Register) value is high, the RTC Divider is cleared. If the DIVRST value is low, the divider operates.

3.15.2 RTC interrupt

RTC has two kinds of interrupt source, Counter Interrupt and Alarm Interrupt. Interrupts are enabled in the NVIC using the appropriate Interrupt Set Enable register. There are following Counter Interrupts: Second, Minute, Hour, Day (Day of Week), Date (Day of Month) and Year. Each bit of RTCINTM (Interrupt Mask Register) can disable or enable interrupt for each Counter Interrupt. Alarm Interrupt can be generated when the Alarm matches with Counter.

3.16 Universal asynchronous receiver/transmitter (UART)

The device embeds three universal asynchronous receivers/transmitters (UART0, UART1, UART2) which communicate at speeds of up to 460.8 Kbit/s. The UART supports synchronous one-way communication, half-duplex single wire communication, and UART0,1 supports multiprocessor communications(CTS/RTS) but UART2 unsupported multiprocessor communications UART2 is called the SUART(Simple UART).

- Serial-to-parallel conversion on data received from a peripheral device
- Parallel-to-serial conversion on data transmitted to the peripheral device
- Data size of 5,6,7 and 8 bits
- One or two stop bits
- Even, odd, stick, or no-parity bit generation and detection
- Support of hardware flow control
- Programmable FIFO disabling for 1-byte depth.
- Programmable use of UART or IrDA SIR input/output
- False start bit detection

UART bidirectional communication requires a minimum of two pins: RX, TX
The frame are comprised of:

- An Idle Line prior to transmission or reception
- A start bit
- A data word (8 or 9 bits) least significant bit first

- 1, 1.5, 2 Stop bits indicating that the frame is complete
- The USART interface uses a baud rate generator
- A status register (UART1_RISR)
- data registers (UART1DR)
- A baud rate register (UART1_IBRD, UART1_FBRD)

3.17 Synchronous Serial Port (SSP)

The SSP block is an IP provided by ARM (PL022 “PrimeCell® Synchronous Serial Port”). Additional details about its functional blocks may be found in “ARM PrimeCell® Synchronous Serial Port (PL022) Technical Reference Manual”.

- The SSP is a master or slave interface that enables synchronous serial communication with slave or master peripherals having one of the following:
 - A MOTOROLA SPI-compatible interface
 - A TEXAS INSTRUMENTS synchronous serial interface
 - A National Semiconductor MICROWIRE® interface.
- The SPI interface operates as a master or slave interface. It supports bit rates up to 20 MHz in master mode and up to 4 MHz in slave mode.
- Parallel-to-serial conversion on data written to an internal 16-bit wide, 8-location deep transmit FIFO
- Serial-to-parallel conversion on received data, buffering it in a 16-bit wide, 8-location deep receive FIFO
- Programmable data frame size from 4 to 16 bits
- Programmable clock bit rate and prescaler. The input clock may be divided by a factor of 2 to 254 in steps of two to provide the serial output clock
- Programmable clock phase and polarity.

3.18 Random number generator (RNG)

RNG is a 32bit random number generator. RNG generates power on random number when power on reset. RNG can run/stop by software. RNG seed value and polynomial of RNG can be modified by software.

- 32bit pseudo random number generator
- Formula of pseudo random number generator (polynomial) can be modified.
- Seed value of random generator can be modified.
- Support power on reset random value.
- Random value can be obtains by control start/stop by software.

4 Pinout and descriptions

4.1 Pin layout

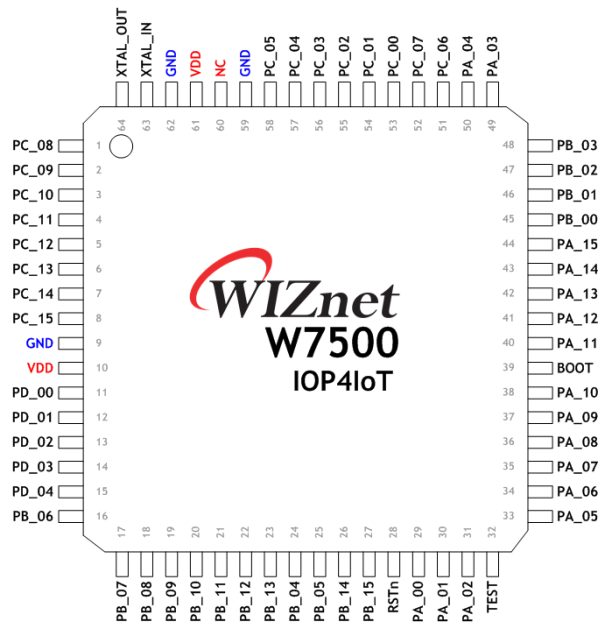

Figure 7 W7500 pin layout

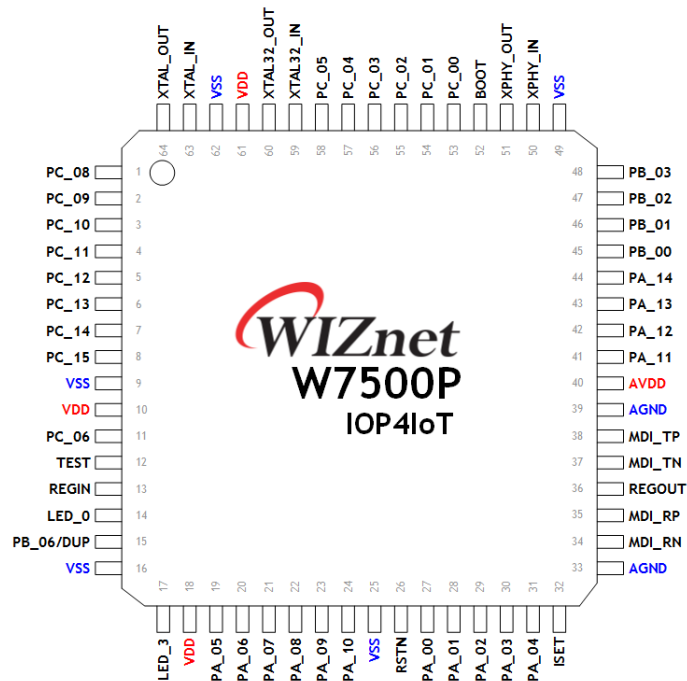

Figure 8 W7500P pin layout

4.2 Pin descriptions

4.2.1 W7500 Pin Description

Table 6. Pin Type Notation

Type	Description
I	Input
O	Output
IO	Input/Output
A	Analog
PWR	Power
GND	Ground

Table 7 W7500 Pin Description

PIN No	Symbol	Type	Function			
			Main Function	2nd Function	3rd Function	4th Function
1	PC_08	AIO	PWM0/CAP0	GPIO3_8	SCL0	NA
2	PC_09	AIO	PWM1/CAP1	GPIO3_9	SDA0	NA
3	PC_10	AIO	U_TXD2	GPIO3_10	PWM2/CAP2	NA
4	PC_11	AIO	U_RXD2	GPIO3_11	PWM3/CAP3	NA
5	PC_12	AIO	NA	GPIO3_12	SSEL0	NA
6	PC_13	AIO	NA	GPIO3_13	SCLK0	NA
7	PC_14	AIO	NA	GPIO3_14	MISO0	NA
8	PC_15	AIO	NA	GPIO3_15	MOSIO	NA
9	GND	GND	GND			
10	VDD	PWR	VDD			
11	PD_00	IO	CRS/TXD3	GPIO4_0		
12	PD_01	IO	RXDV/TXD2	GPIO4_1		
13	PD_02	IO	RXD0/TXD1	GPIO4_2		
14	PD_03	IO	RXD1/TXD0	GPIO4_3		
15	PD_04	IO	RXD2/TXCLK	GPIO4_4		
16	PB_06	IO	RXD3/DUP	GPIO2_6		
17	PB_07	IO	RXCLK/RXCLK	GPIO2_7		
18	PB_08	IO	DUP/RXD3	GPIO2_8		
19	PB_09	IO	TXCLK/RXD2	GPIO2_9		

PIN No	Symbol	Type	Function			
			Main Function	2nd Function	3rd Function	4th Function
20	PB_10	IO	TXD0/RXD1	GPIO2_10		
21	PB_11	IO	TXD1/RXD0	GPIO2_11		
22	PB_12	IO	TXD2/RXDV	GPIO2_12		
23	PB_13	IO	TXD3/CRS	GPIO2_13		
24	PB_04	IO	TXEN	GPIO2_04		
25	PB_05	IO	COL	GPIO2_05		
26	PB_14	IO	MDIO/MDC	GPIO2_14		
27	PB_15	IO	MDC/MDIO	GPIO2_15		
28	RSTn	I	RSTn			
29	PA_00	IO	GPIO1_0	GPIO1_0	PWM6/CAP6	
30	PA_01	IO	GPIO1_1	GPIO1_1	PWM7/CAP7	
31	PA_02	IO	GPIO1_2	GPIO1_2	CLKOUT	
32	TEST	IO	TEST			
33	PA_05	IO	SSEL0	GPIO1_5	SCL1	PWM2/CAP2
34	PA_06	IO	SCLK0	GPIO1_6	SDA1	PWM3/CAP3
35	PA_07	IO	MISO0	GPIO1_7	U_CTS1	PWM4/CAP4
36	PA_08	IO	MOSI0	GPIO1_8	U_RTS1	PWM5/CAP5
37	PA_09	IO	SCL0	GPIO1_9	U_TXD1	PWM6/CAP6
38	PA_10	IO	SDA0	GPIO1_10	U_RXD1	PWM7/CAP7
39	BOOT	IO	BOOT			
40	PA_11	IO	U_CTS0	GPIO1_11	SSEL1	
41	PA_12	IO	U_RTS0	GPIO1_12	SCLK1	
42	PA_13	IO	U_TXD0	GPIO1_13	MISO11	
43	PA_14	IO	U_RXD0	GPIO1_14	MOSI1	
44	PA_15	IO	GPIO1_15	GPIO1_15		
45	PB_00	IO	SSEL1	GPIO2_0	U_CTS0	
46	PB_01	IO	SCLK1	GPIO2_1	U_RTS0	
47	PB_02	IO	MISO1	GPIO2_2	U_TXD0	

PIN No	Symbol	Type	Function			
			Main Function	2nd Function	3rd Function	4th Function
48	PB_03	IO	MOSI1	GPIO2_3	U_RXD0	
49	PA_03	IO	SWCLK	GPIO1_3		PWM0/CAP0
50	PA_04	IO	SWDIO	GPIO1_4		PWM1/CAP1
51	PC_06	IO	GPIO3_6	GPIO3_6	U_TXD2	
52	PC_07	IO	GPIO3_7	GPIO3_7	U_RXD2	
53	PC_00	IO	U_CTS1	GPIO3_0	PWM0/CAP0	
54	PC_01	IO	U_RTS1	GPIO3_1	PWM1/CAP1	
55	PC_02	IO	U_TXD1	GPIO3_2	PWM2/CAP2	
56	PC_03	IO	U_RXD1	GPIO3_3	PWM3/CAP3	
57	PC_04	IO	SCL1	GPIO3_4	PWM4/CAP4	
58	PC_05	IO	SDA1	GPIO3_5	PWM5/CAP5	
59	GND	GND	GND			
60	NC	NC	NC			
61	VDD	PWR	VDD			
62	GND	GND	GND			
63	XTAL_IN	I	Xtal in			
64	XTAL_OUT	O	Xtal out			

4.2.2 W7500P Pin Description

Table 8. W7500P Pin Description

PIN No	Symbol	Type	Function				
			Main Function	2nd Function	3rd Function	4th Function	PHY
1	PC_08	AIO	PWM0/CAP0	GPIO3_8	SCL0	NA	
2	PC_09	AIO	PWM1/CAP1	GPIO3_9	SDA0	NA	
3	PC_10	AIO	U_TXD2	GPIO3_10	PWM2/CAP2	NA	
4	PC_11	AIO	U_RXD2	GPIO3_11	PWM3/CAP3	NA	
5	PC_12	AIO	NA	GPIO3_12	SSEL0	NA	
6	PC_13	AIO	NA	GPIO3_13	SCLK0	NA	
7	PC_14	AIO	NA	GPIO3_14	MISO0	NA	
8	PC_15	AIO	NA	GPIO3_15	MOSIO	NA	
9	VSS	GND	VSS				
10	VDD	PWR	VDD				
11	PC_06	IO	GPIO3_6	GPIO3_6	U_TXD2		
12	TEST	IO	TEST				
13	REGIN	PWR	REGIN				
14	LED_0	IO	LED_0				LED_0
15	PB_06/DUP	IO	DUP				DUP
16	VSS	IO	VSS				
17	LED_3	IO	LED_3				LED_3
18	VDD	PWR	VDD_IO				
19	PA_05	IO	SSEL0	GPIO1_5	SCL1	PWM2/CAP2	
20	PA_06	IO	SCLK0	GPIO1_6	SDA1		
21	PA_07	IO	MISO0	GPIO1_7	U_CTS1	PWM4/CAP4	
22	PA_08	IO	MOSIO	GPIO1_8	U_RTS1	PWM5/CAP5	
23	PA_09	IO	SCL0	GPIO1_9	U_TXD1	PWM6/CAP6	
24	PA_10	IO	SDA0	GPIO1_10	U_RXD1	PWM7/CAP7	
25	VSS	IO	VSS_IO				

PIN No	Symbol	Type	Function				
			Main Function	2nd Function	3rd Function	4th Function	PHY
26	RSTN	I	RSTN				
27	PA_00	IO	GPIO1_0	GPIO1_0	PWM6/CAP6		
28	PA_01	IO	GPIO1_1	GPIO1_1	PWM7/CAP7		
29	PA_02	IO	GPIO1_2	GPIO1_2	CLKOUT		
30	PA_03	IO	GPIO1_3	GPIO1_3		PWM0/CAPO	
31	PA_04	IO	GPIO1_4	GPIO1_4			
32	ISET	I	ISET				ISET
33	AGND	GND	AGND				
34	MDI_RN	IO	MDI_RN				MDI_RN
35	MDI_RP	IO	MDI_RP				MDI_RP
36	REGOUT	PWR	REGOUT				
37	MDI_TN	IO	MDI_TN				MDI_TN
38	MDI_TP	IO	MDI_TP				MDI_TP
39	AGND	GND	AGND				
40	AVDD	PWR	AVDD				
41	PA_11	IO	U_CTS0	GPIO1_11	SSEL1		
42	PA_12	IO	U_RTS0	GPIO1_12	SCLK1		
43	PA_13	IO	U_TXD0	GPIO1_13	MISO1		
44	PA_14	IO	U_RXD0	GPIO1_14	MOSI1		
45	PB_00	IO	SSEL1	GPIO2_0	U_CTS0		
46	PB_01	IO	SCLK1	GPIO2_1	U_RTS0		
47	PB_02	IO	MISO1	GPIO2_2	U_TXD0		
48	PB_03	IO	MOSI1	GPIO2_3	U_RXD0		
49	VSS	PWR	VSS_IO				
50	XPHY_IN	I	25MHz xtal in				
51	XPHY_OUT	O	25MHz xtal out				
52	BOOT	IO	BOOT				
53	PC_00	IO	U_CTS1	GPIO3_0	PWM0/CAPO		

PIN No	Symbol	Type	Function				
			Main Function	2nd Function	3rd Function	4th Function	PHY
54	PC_01	IO	U_RTS1	GPIO3_1			
55	PC_02	IO	U_TXD1	GPIO3_2	PWM2/CAP2		
56	PC_03	IO	U_RXD1	GPIO3_3			
57	PC_04	IO	SCL1	GPIO3_4	PWM4/CAP4		
58	PC_05	IO	SDA1	GPIO3_5	PWM5/CAP5		
59	XTAL32_IN	I	32768Hz xtal in				
60	XTAL32_OUT	O	32768Hz xtal out				
61	VDD	PWR	VDD				
62	VSS	GND	VSS				
63	XTAL_IN	I	Xtal in				
64	XTAL_OUT	O	Xtal out				

5 Electrical characteristics

5.1 Absolute maximum ratings

These are stress ratings only and functional operation of the device at these conditions is not implied. Exposure to maximum rating conditions for extended periods may affect device reliability.

5.2 Voltage Characteristics

Table 9 shows the voltage characteristics of W7500x.

Table 9 Voltage characteristics

Symbol	Ratings	Min	Max	Unit
V_{DD-VSS}	Main supply voltage (VDD)	-0.3	3.6	V
V_{IN}	Input voltage on IO pins	VSS - 0.3	3.6	V
S_{VDDH}	I/O Power on slope	3.3V/Sec	1V/uSec	-
ΔV_{DD}	Variations between difference VDD power pins		50	mV
ΔV_{SS}	Variations between different ground pins		50	mV

5.3 Current Characteristics

Table 10 shows the current characteristics of W7500x.

Table 10 Current characteristics

Symbol	Ratings	Max	Unit
I_{VDD_SUM}	Total current into sum of all VDD power lines (source)	100	mA
I_{VDD}	Maximum current into each ADD power pin (source)	90	mA
I_{IO_PAD}	Total output current sunk by sum of all IOs and control pins	75	mA
I_{INJ_PAD}	Single pin input injected current	± 10	mA
I_{INJ_SUM}	Sum of all input injected current	± 50	mA

5.4 Thermal Characteristics

Table 11 shows the thermal characteristics of W7500x.

Table 11 Thermal Characteristics

Symbol	Ratings		Min	Max	Unit
$T_{Storage}$	Storage temperature range		-55	150	°C
T_{Junc}	Maximum junction temperature under bias	W7500	-40	150	
		W7500P	0	125	
T_A	Ambient Operating Temperature	W7500	-40	85	
		W7500P	0	70	

5.5 Operating conditions

5.5.1 General Operating Conditions

Table 12 shows the general operating conditions of W7500x.

Table 12 General operating conditions

Symbol	Parameter	Conditions	Min	Max	Unit
f_{CLK}	Internal CPU clock frequency		0	48	MHz
V_{DD}	Standard operating voltage		2.7	3.6	V
V_{IO}	Input voltage on PIN		$V_{SS}-0.3$	3.6	V

5.6 Supply Current Characteristics

Normal operation

Table 13 shows the Normal operation supply current.

Table 13 Normal operation supply current

Symbol	Parameter	Conditions1	Condition2	Typ	Unit
I _{DD_NOR}	Supply current	Active mode; code While(1) {} Executed from flash memory	System clock = 10MHz	6.14 (52.14) ⁽¹⁾ (22.14) ⁽²⁾	mA
			System clock = 20MHz	8.82 (54.82) ⁽¹⁾ (24.82) ⁽²⁾	mA
			System clock = 40MHz	14.09 (60.09) ⁽¹⁾ (30.09) ⁽²⁾	mA

(1) When PHY Normal mode, W7500P Internal PHY power consumption is 46mA MAX.

(2) When PHY Power down mode, W7500P Internal PHY power consumption is 16mA MAX.

Sleep mode

Table 14 shows the Normal operation supply current.

Table 14 Sleep mode supply current

Symbol	Parameter	Conditions1	Condition2	Typ	Unit
I _{DD_SLP}	Supply current	After enter sleep mode All peripheral clocks ON (same as system clock)	System clock = 10MHz	3.51 (49.51) ⁽¹⁾ (19.51) ⁽²⁾	mA
			System clock = 20MHz	5.65 (51.65) ⁽¹⁾ (21.65) ⁽²⁾	mA
			System clock = 40MHz	9.61 (55.61) ⁽¹⁾ (25.61) ⁽²⁾	mA

(3) When PHY Normal mode, W7500P Internal PHY power consumption is 46mA MAX.

(4) When PHY Power down mode, W7500P Internal PHY power consumption is 16mA MAX.

Deep sleep mode

Table 15 shows the deep sleep mode operation supply current.

Table 15 Deep sleep mode supply current

Symbol	Parameter	Conditions1	Condition2	Typ	Unit
I _{DD_DSLP}	Supply current	After enter deep sleep mode All peripheral clocks OFF	-	2.49 (48.49) ⁽¹⁾ (18.49) ⁽²⁾	mA

(5) When PHY Normal mode, W7500P Internal PHY power consumption is 46mA MAX.

(6) When PHY Power down mode, W7500P Internal PHY power consumption is 16mA MAX.

5.7 I/O PAD Characteristics

DC Specification

Table 16 shows the DC specification of W7500x I/O PAD.

Table 16 DC specification of PAD

Symbol	Parameter	Conditions	Min	Max	Unit
V _{IH}	I/O Input high voltage		2.145		V
V _{IL}	I/O Input low voltage			1.155	V
V _{HYS}	Schmitt trigger hysteresis		0.33		V
I _{IH}	I/O Input high current			1	uA
I _{IL}	I/O Input low current		-1		uA
V _{OH}	I/O Output high voltage	High driving strength Iload = 6mA Low driving strength Iload = 3mA	2.5		V
V _{OL}	I/O Output low voltage	High driving strength Iload = 6mA Low driving strength Iload = 3mA		0.5	V
R _{pup} R _{pdn}	Pull-up /Pull-down resistor		20	100	KOhm

Flash memory

Table 17 shows the flash memory reliability characteristics of W7500x

Table 17 Flash memory Reliability Characteristics

Symbol	Parameter	Min	Unit
N _{END}	Sector Endurance	10,000	Cycles
T _{DR}	Data Retention	10	Years

5.8 Electrical Sensitivity Characteristics

Electrostatic discharge (ESD)

Table 18 shows the ESD information of W7500x

Table 18 Electrostatic discharge (ESD)

Symbol	Parameter	Test Method	Min	Max	Unit
V _{ESD(HBM)}	Electrostatic discharge (Human body model)	AEC-Q100-002	±2000	-	V
V _{ESD(CDM)}	Electrostatic discharge (Charge device model)	AEC-Q100-011	±500	-	V

Static latch-up

Table 19 shows the Static latch-up information of W7500x

Table 19 Static latch-up

Symbol	Parameter	Test Method	Min	Max	Unit
I _{LAT}	Latch up current at 125 °C ambient temperature	AEC-Q100-004	±100	-	V

5.9 Reset & PLL Characteristics

PLL Electrical characteristics

Table 20 shows the PLL characteristics of W7500x

Table 20 PLL electrical characteristics

Symbol	Parameter	Min	Max	Unit
t_d	RSTn to PD delay time	5	-	us
t_{rst}	Reset pulse width	2	-	us
t_{lock}	Lock time	-	0.2	ms

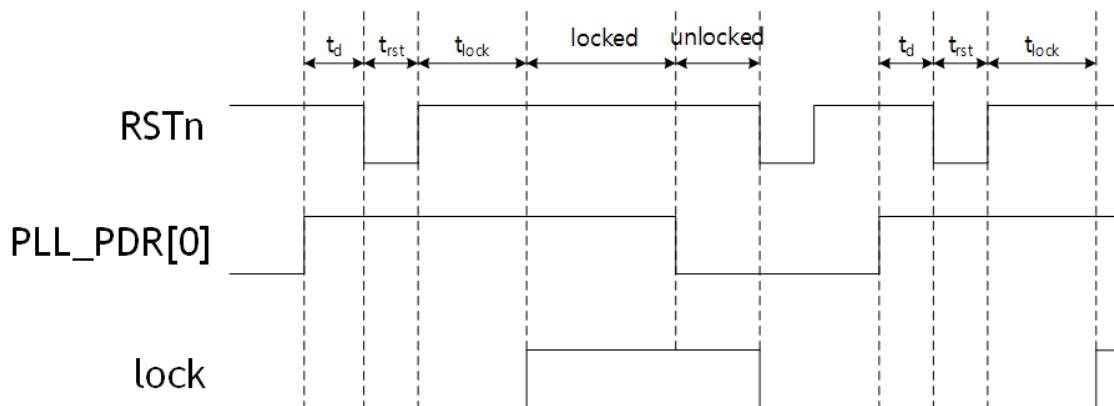

Figure 9 Power Down operation Timing Sequence for PLL

Notice:

PLL_PDR[0] is LSB of PLL_PDR. please refer from Reference Manual.

lock signal is internal signal.

1, t_d is the RSTn to PLL_PDR[0] delay time, which need larger than 5us.

2, t_{rst} is the reset pulse width, which need larger than 2us.

3, t_{lock} is the lock time, which is less than 0.2ms.

4, When PLL_PDR[0] changes from "1" to "0", the lock signal stays in "1" until a reset pulse comes. But the PLL is in unlocked state during this period.

5.10 SSP Interface Characteristics

The maximum SSP speed is 20 Mbit/s in master mode or 4 Mbit/s in slave mode. In slave mode, the maximum SSP clock rate must be 1/12 of the SSP PCLK clock rate.

Table 21 shows the SSP characteristics of W7500x.

Table 21 SSP characteristics

Symbol	Parameter	Min	Nom	Max	Unit
t_{clk_per}	SSPCLK cycle time	2		65024	System clocks
t_{clk_high}	SSPCLK high time	-	0.5		t_{clk_per}
t_{clk_low}	SSPCLK low time	-	0.5		t_{clk_per}
t_{clkrf}	SSPCLK rise/fall time	-	6	10	
t_{DMd}	Data from master valid delay time	0	-	1	System clocks
t_{DMs}	Data from master setup time	1	-	-	System clocks
t_{DMh}	Data from master hold time	2	-	-	System clocks
t_{Dss}	Data from slave setup time	1	-	-	System clocks
t_{Dsh}	Data from slave hold time	2	-	-	System clocks

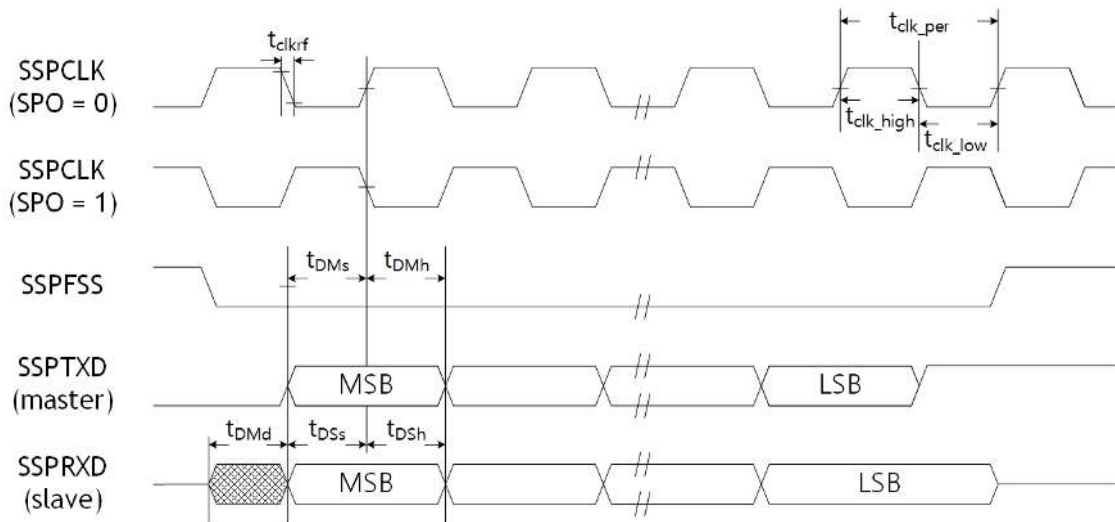

Figure 10. SSP Timing for SPI Frame format, with SPH =1

6 Package Information

6.1 Package dimension information

Figure 11 shows the package dimension information.

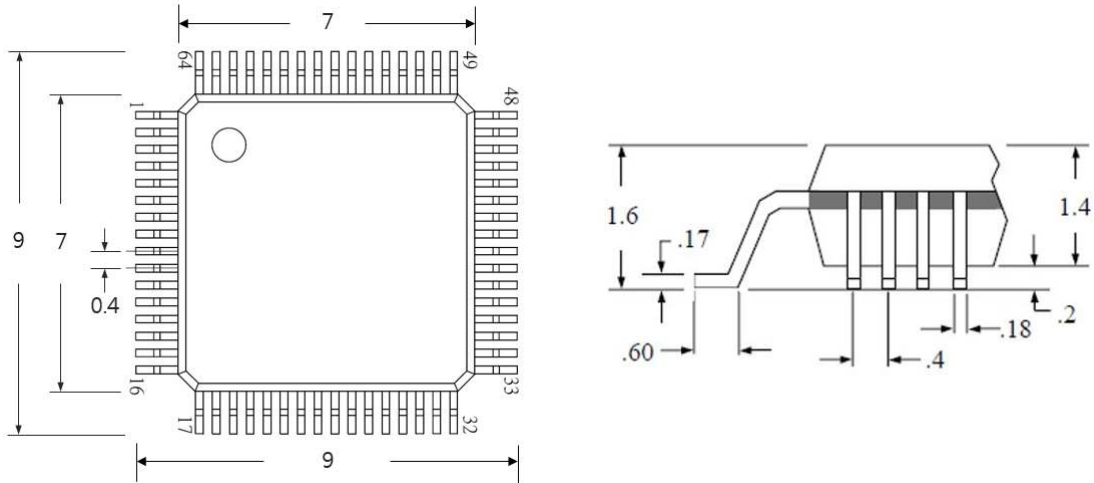

Figure 11. Package Dimension Information

Document History Information

Version	Date	Descriptions
Ver. 1.0.0	18SEP2017	Initial Release
Ver. 1.0.1	26OCT2017	Fixed value Driving Strength condition in PADCON.
Ver. 1.0.2	09NOV2017	Fixed Typo I/O Pad Characteristics VOL description (high -> low)
Ver. 1.0.3	30NOV2017	Fixed figure 8. (W7500P Pin out)
Ver. 1.0.4	18DEC2017	Add Reset & PLL characteristics.
Ver. 1.0.5	30JAN2018	<ol style="list-style-type: none"> 1. Fixed figure 8 (W7500P Pin layout) / Added subhead (4.2.1 W7500, 4.2.2 W7500P) / Fixed table 8(modified Symbol name) 2. Modified SRAM description (2. Description)
Ver. 1.0.6	05FEB2018	Add info about W7500P power consumption.(Current Characteristics)
Ver. 1.0.7	27JUL2018	Fixed figure 2. CRG Diagram (Input Information of WDOGCLK, TIMCLK0, TIMCLK1).
Ver. 1.0.8	17OCT2018	Fixed Power Supply description (271V - 5.5V -> 2.7V - 3.6V)
Ver. 1.0.9	12NOV2019	<p>Fixed 5.2 I/O Power on slope (5V/sec -> 3.3V)</p> <p>The ADC causes the interference between channels. So all explain of ADC are removed</p>
Ver 1.1.0	20DEC2019	Fixed 3.17 UART speed to 460.8 Kbit/s from 3 Mbit/s.

Copyright Notice

Copyright 2017 WIZnet Co., Ltd. All Rights Reserved.

Technical Support: <https://forum.wizwiki.io/>

Sales & Distribution: sales@wiznet.io

For more information, visit our website at <http://www.wiznet.io/>