

PC BOARD VERSIONS		
PRODUCTNR.	PCB THICKNESS	DIM"A"
70229-X01LF		
70229-X11LF		

OBSOLETE 
OBSOLETE 

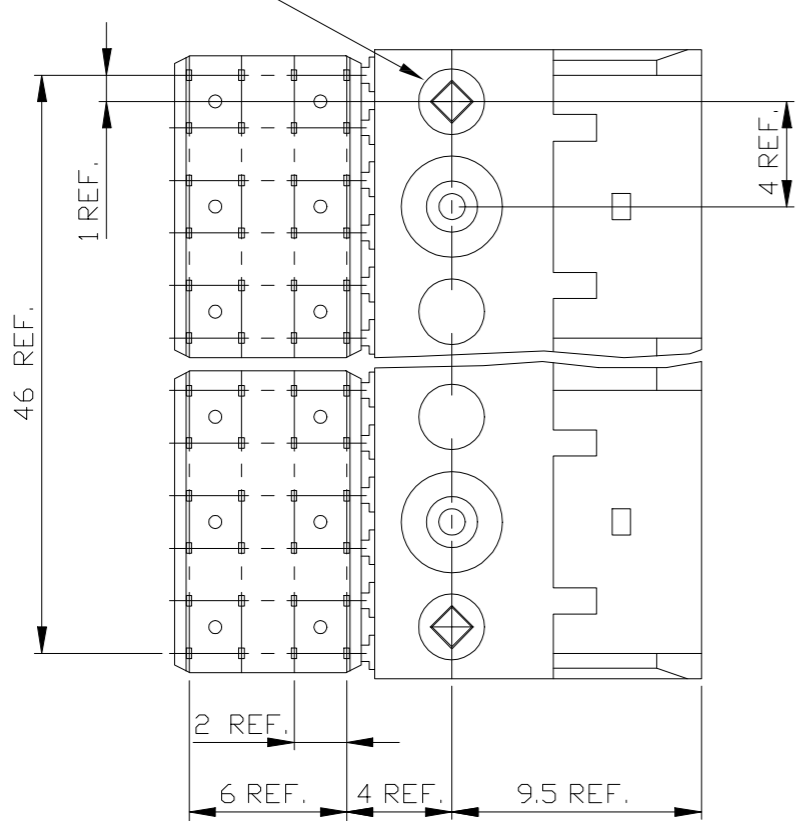

NOTE 6

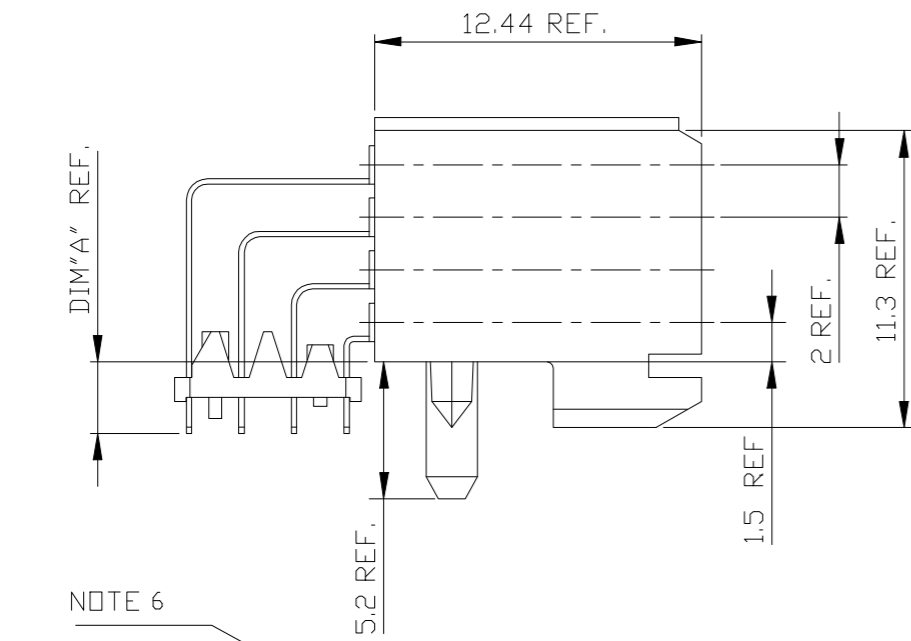
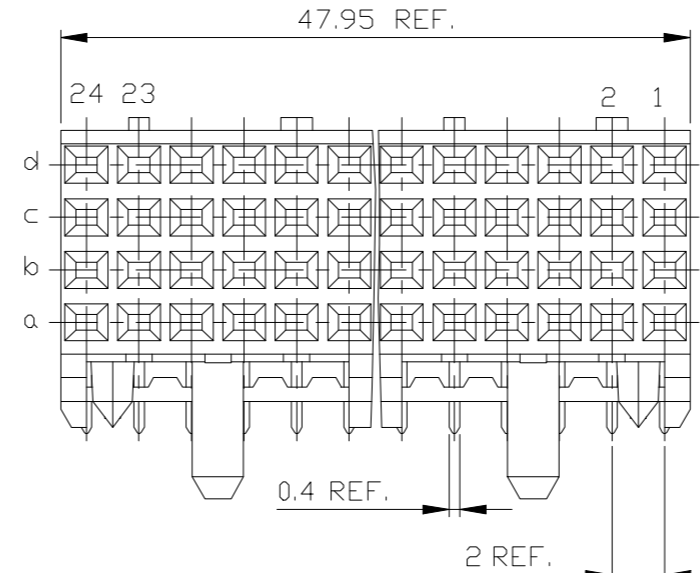

PRODUCT AFTER HOT RIVETTING

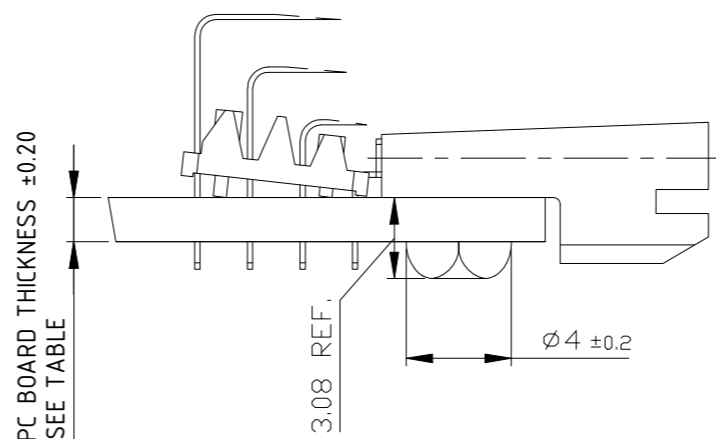

PART NUMBER : 70229-XY1LF

REFER NOTE 2

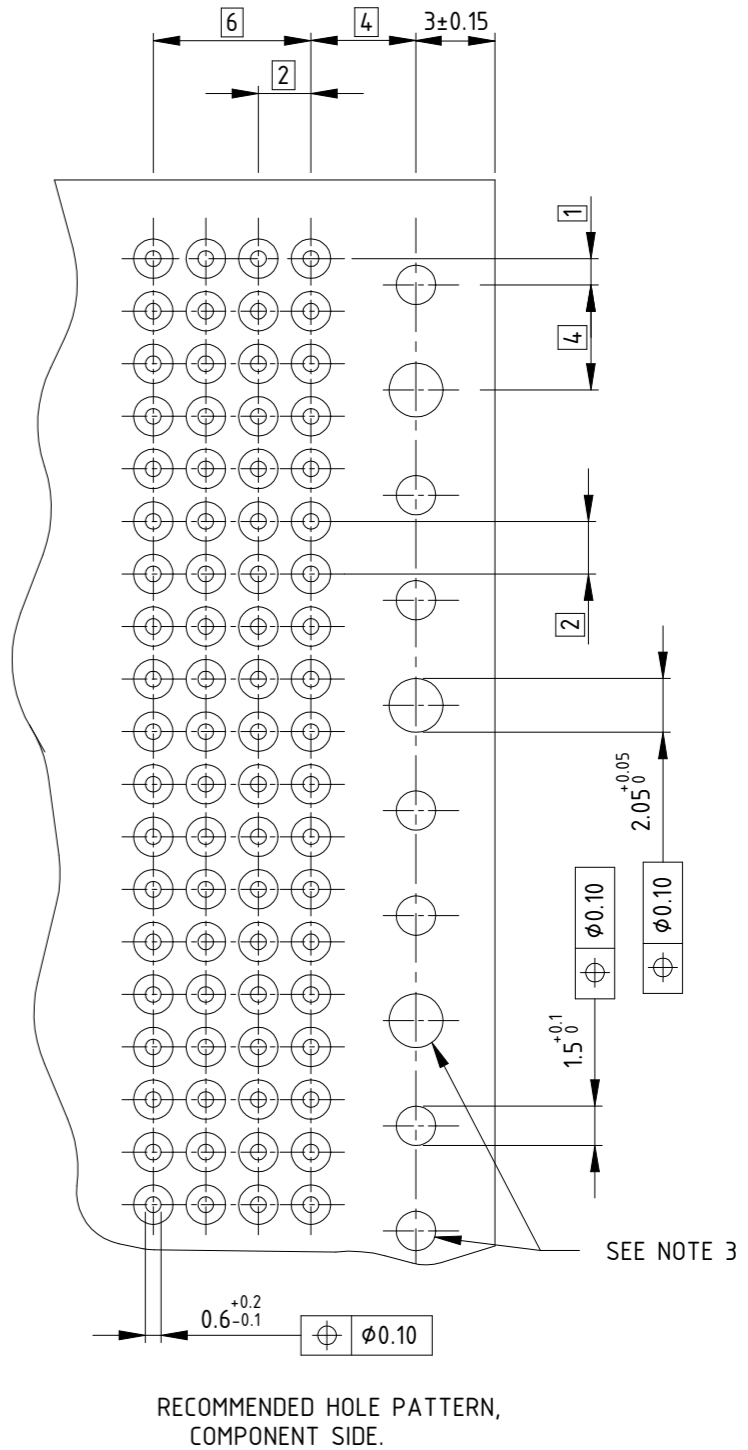

RECOMMENDED HOLE PATTERN, COMPONENT SIDE.

NOTES:

- MATERIAL : BODY : LCP UL94-V0
: CONTACT : COPPER ALLOY.
- FOR PLATING PERFORMANCE REFER DRAWING # 10159408.
- INDICATED HOLES ARE UNPLATED.
- THIS PRODUCT MEETS EUROPEAN UNION DIRECTIVES AND OTHER COUNTRY REGULATIONS AS DESCRIBED IN GS-47-0004.
- THE HOUSING WILL WITHSTAND EXPOSURE TO 260° PEAK TEMPERATURE FOR 10 SECONDS IN A WAVE SOLDER APPLICATION.
- DIAMOND LOCATION PEG ARE ONLY EXISTED ON THE BOTH SIDES OF PRODUCT.
- A  SYMBOL WILL BE NEXT TO ANY DIMENSION, VIEW, OR NOTE WHICH HAS BEEN MODIFIED WITH THE CURRENT DRAWING REVISION.

mat'l. code		surface		tolerance		projection		product family	
		ISO 1302		ISO 406 ISO 1101				METRAL (tm)	
lfr		ecn no		dr		date		title	
K		DG04-0104		CLU		2004-12-21		RA FEMALE SIGNAL	
L		DG06-0477		CENH		2006-11-20		STB 48mm VERSION	
M		DG07-0168		CENH		2007-05-08		dwg no	
N		DG09-0068		CENH		2009-06-06		70229	
P		ELX-I-38935		MINI		2020-11-12		sheet 1 of 3	
R		ELX-I-44054		NIRHAL		2022-03-07		size	
								A2	
sheet index		revision		R		R		type	
1		1		2		3		Product Customer Drawing	

PC BOARD VERSIONS		
PRODUCTNR:	PCB THICKNESS	DIM"A"
70229-X02LF	1.6	2.90
70229-X12LF	2.4	3.53

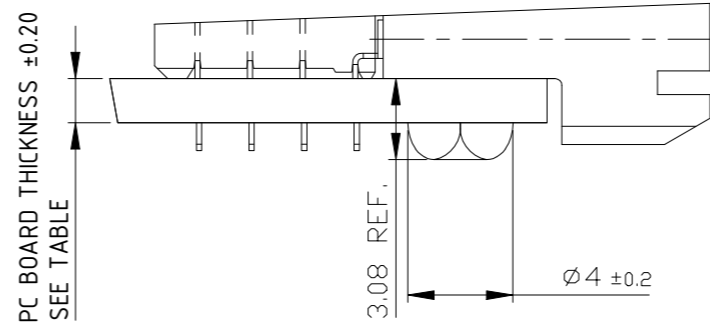
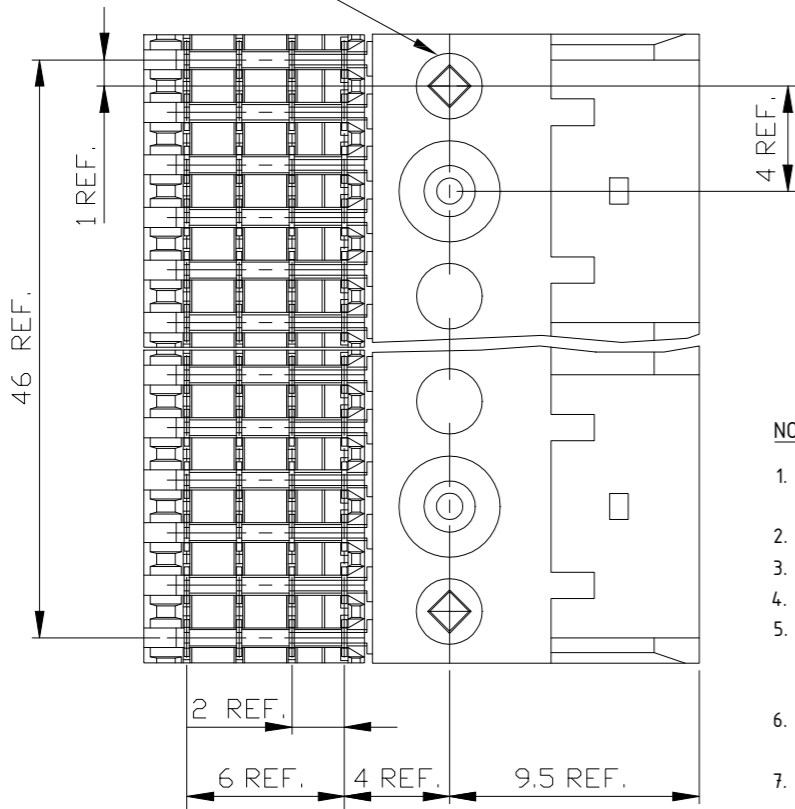
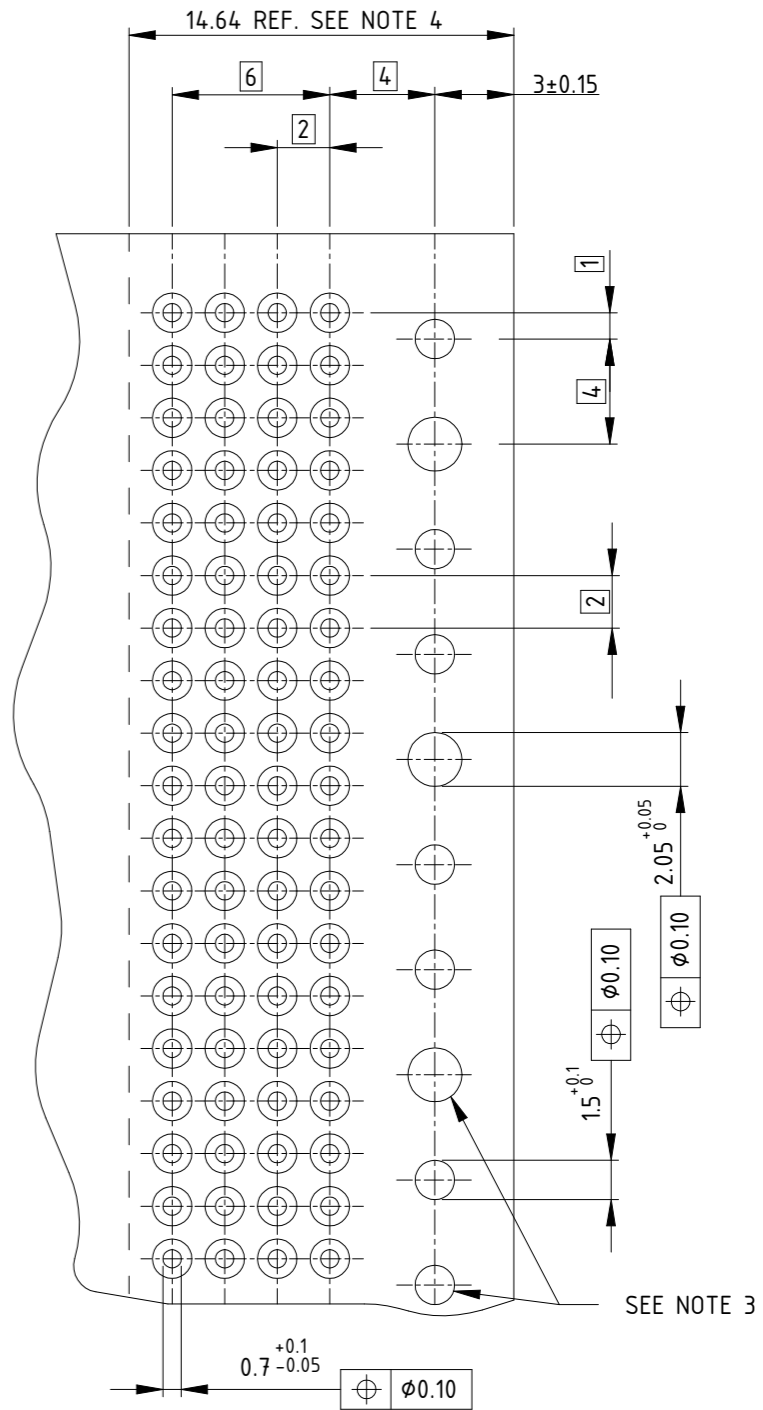
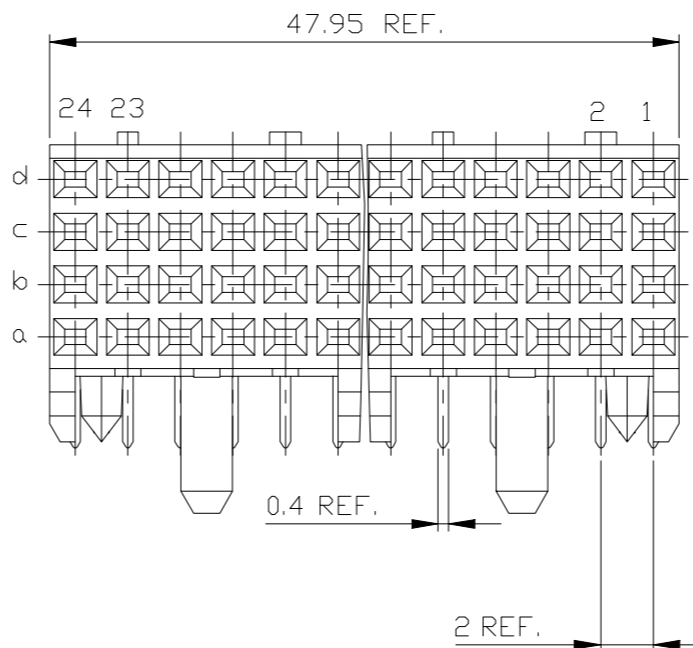
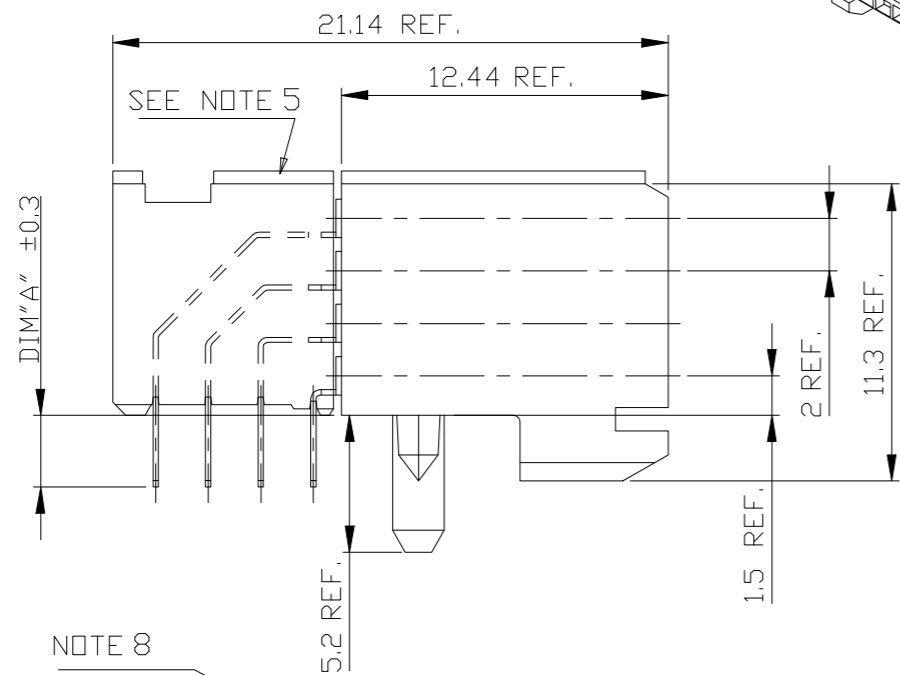
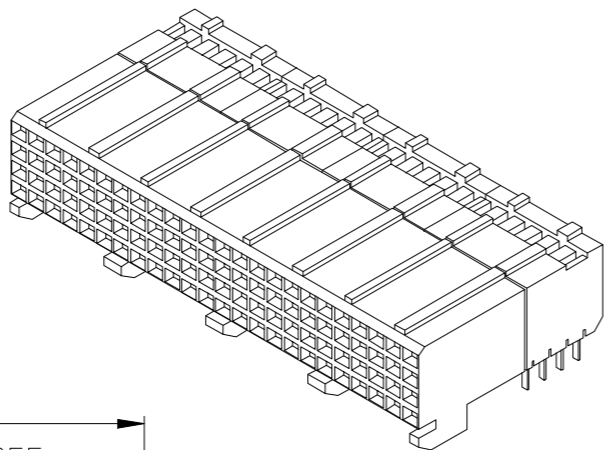

NOTES:

1. MATERIAL : BODY : LCP UL94-V0
: CONTACT : COPPER ALLOY.
2. FOR PLATING PERFORMANCE REFER DRAWING # 10159408
3. INDICATED HOLES ARE UNPLATED
4. SET BACK FOR TAIL BLOCK
5. TOP SURFACE OF PRESS BLOCK MAY EXTEND UP TO 0.4MM HIGHER THAN HOUSING. THIS MAY AFFECT THE TAIL LENGTH BEFORE APPLICATION TO A BOARD.
6. THIS PRODUCT MEETS EUROPEAN UNION DIRECTIVES AND OTHER COUNTRY REGULATIONS AS DESCRIBED IN GS-47- 0004
7. THE HOUSING WILL WITHSTAND EXPOSURE TO 260° PEAK TEMPERATURE FOR 10 SECONDS IN A WAVE SOLDER APPLICATION
8. DIAMOND LOCATION PEG ARE ONLY EXISTED ON THE BOTH SIDES OF PRODUCT.
9. A SYMBOL WILL BE NEXT TO ANY DIMENSION, VIEW, OR NOTE WHICH HAS BEEN MODIFIED WITH THE CURRENT DRAWING REVISION.

PART NUMBER : 70229-XYLFF

REFER NOTE 2

mat'l. code		surface	tolerance	projection	product family
		ISO 1302	ISO 406 ISO 1101		METRAL (tm)
		tolerances unless otherwise specified			title
lfr	ecn no	dr	date	angles	RA FEMALE SIGNAL
K	DG04-0104	CLU	2004-12-21	linear	STB 48mm VERSION
L	DG06-0477	CENH	2006-11-20	0°±2°	dwg no
M	DG07-0168	CENH	2007-05-08		70229
N	DG09-0068	CENH	2009-06-06		sheet 2 of 3
P	ELX-I-38935	MINI	2020-11-12		size
R	ELX-I-44054	NRHAL	2022-03-07		A2
		appd	SANOJ	2020-11-12	type
sheet	revision	R	R	R	Product Customer Drawing
index	sheet	1	2	3	

PC BOARD VERSIONS		
PRODUCTNR:	PCB THICKNESS	DIM "A"
70229-X03LF	1.6	2.90
70229-X13LF	2.4	3.53

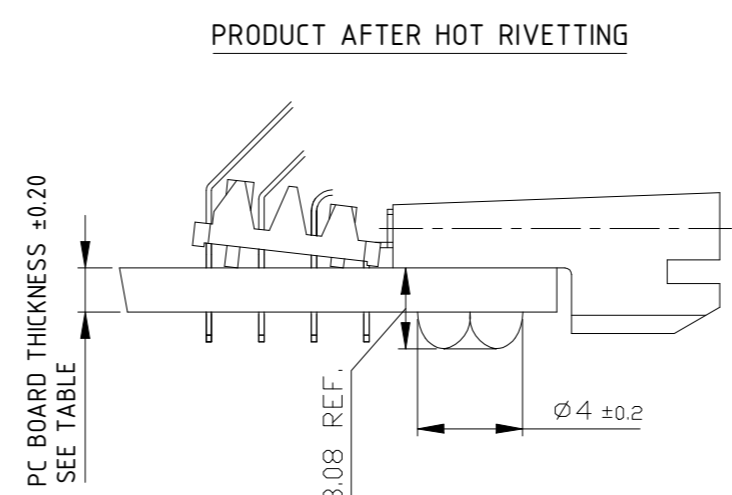
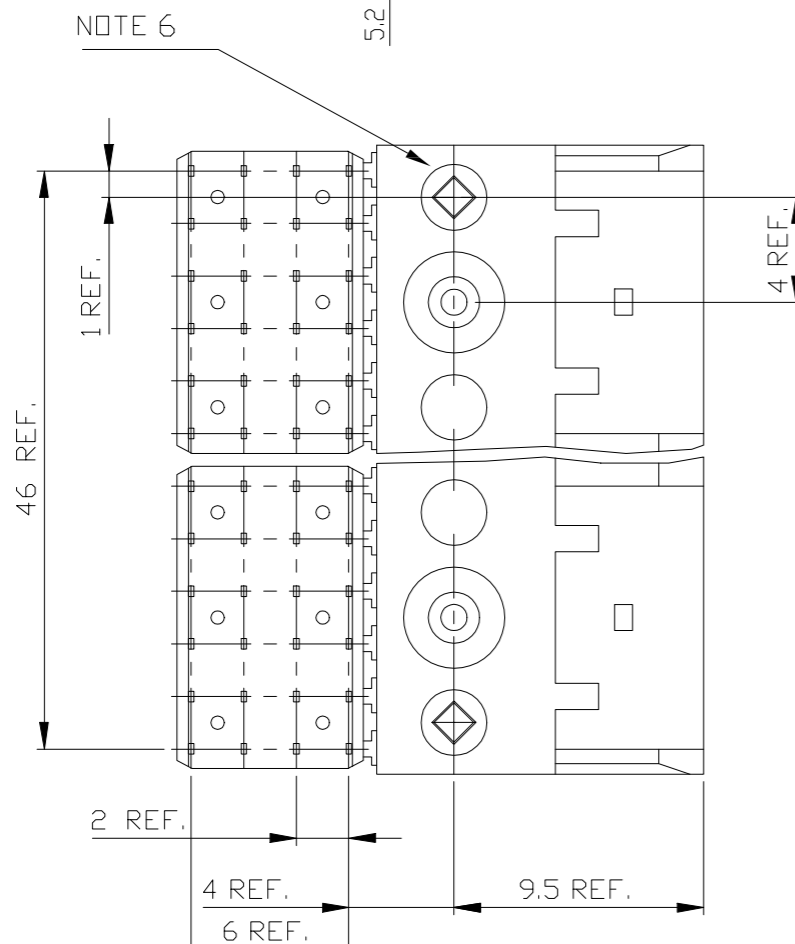
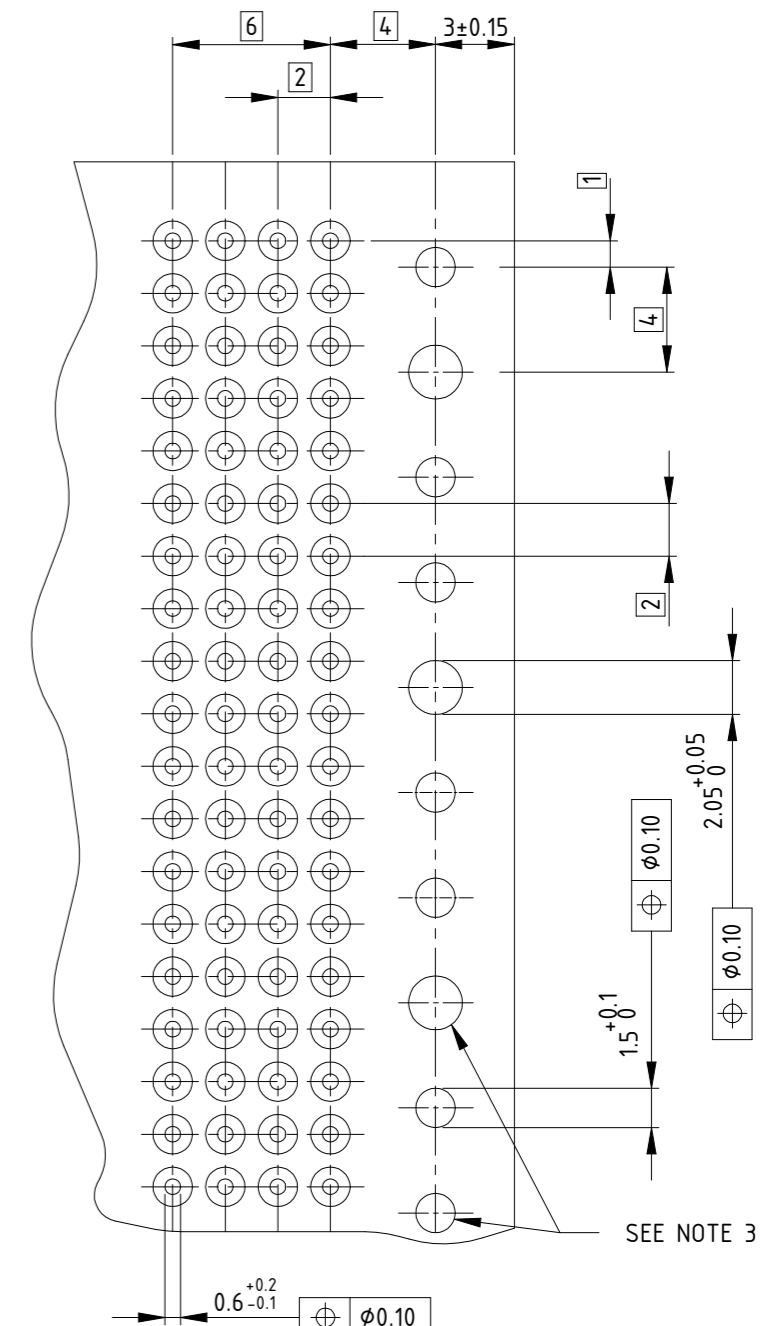
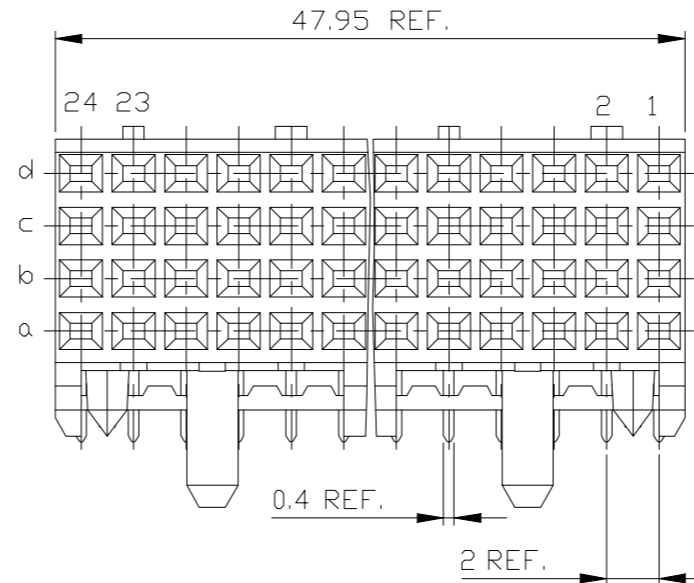
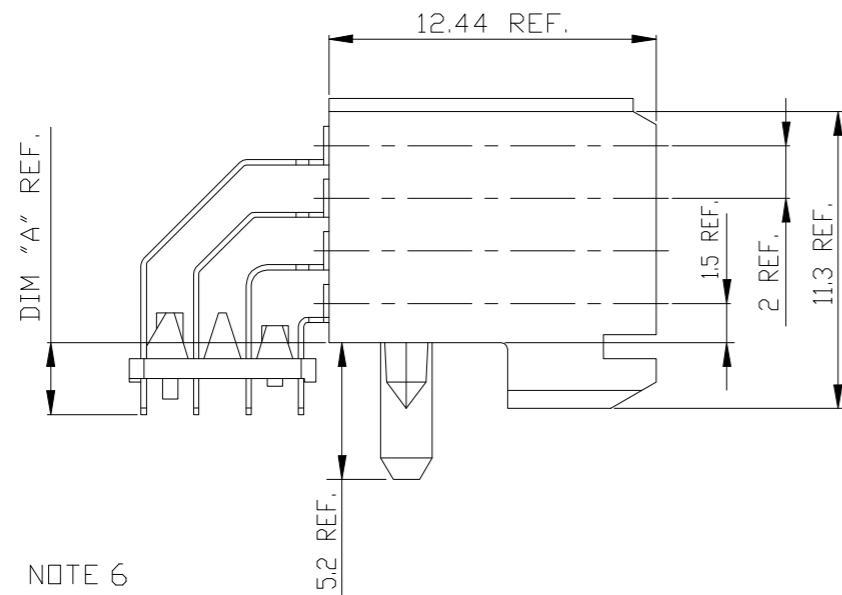

PRODUCT AFTER HOT RIVETTING

RECOMMENDED HOLE PATTERN, COMPONENT SIDE.

NOTES:

- MATERIAL : BODY : LCP UL94-V0
: CONTACT : COPPER ALLOY.
- FOR PLATING PERFORMANCE REFER DRAWING # 10159408.
- INDICATED HOLES ARE UNPLATED.
- THIS PRODUCT MEETS EUROPEAN UNION DIRECTIVES AND OTHER COUNTRY REGULATIONS AS DESCRIBED IN GS-47-0004.
- THE HOUSING WILL WITHSTAND EXPOSURE TO 260° PEAK TEMPERATURE FOR 10 SECONDS IN A WAVE SOLDER APPLICATION.
- DIAMOND LOCATION PEG ARE ONLY EXISTED ON THE BOTH SIDES OF PRODUCT.
- A Δ SYMBOL WILL BE NEXT TO ANY DIMENSION, VIEW, OR NOTE WHICH HAS BEEN MODIFIED WITH THE CURRENT DRAWING REVISION.

REFER NOTE 2
PART NUMBER : 70229-XYLFF

mat'l. code		surface		tolerance		projection		product family	
		ISO 1302		ISO 406 ISO 1101		mm		METRAL (tm)	
lfr		ecn no		date		tolerances unless otherwise specified		title	
K	DG04-0104	CLU	2004-12-21					RA FEMALE SIGNAL	
L	DG06-0477	CENH	2006-11-20					STB 48mm VERSION	
M	DG07-0168	CENH	2007-05-08	0°±2°				dwg no	
N	DG09-0068	CENH	2009-06-06	dr		HEAVEN CEN 1990-09-18		sheet 3 of 3	
P	ELX-I-38935	MINI	2020-11-12	engr		ARUN 2020-11-12		size	
R	ELX-I-44054	NIRHAL	2022-03-07	chr		ALEX 2020-11-12		A2	
sheet index		revision sheet		R R R		1 2 3		type Product Customer Drawing	