



SPECIFICATION FOR APPROVAL

CUSTOMER : _____

PRODUCT TYPE : SMD SEAM SEALING CXO 2.5 × 2.0

NOMINAL FREQ. : 48.000000MHz

TXC P/N : 8W48070009

REVISION : S2

CUSTOMER P/N : _____

PM / SALES : _____

DATE : _____

CUSTOMER CONFIRMATION : _____
 (Singnature)

(Date)

- (1) TXC requires one copy returned with signature and title of authorized individual that signifies acceptance of the attached specifications.
- (2) Orders received and accepted by TXC after return of signed copy of specification will be produced per these specifications.
- (3) Any changes to these specifications must be agreed upon by both parties and new revision of the Product Specification Sheet will be issued.
- (4) Any issuance of purchase order prior to consigning back the Approval page of "Specification Sheets" from customers will be regarded as the agreement on the contents of these specifications.

MSL:Level 1
RoHS Compliant

(for glass crystal only : Pb used in sealing glass material is exempt from EU directive)



PRODUCT SPECIFICATION SHEET

PRODUCT TYPE : SMD SEAM SEALING CXO 2.5 × 2.0

NOMINAL FREQ. : 48.000000MHz

TXC P/N : 8W48070009

REVISION : S2

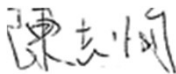
PE/RD	QA	MFG
 Oscar Chen		
2-Jul-21		

NOTE:

- (1) If customer's application involves ultrasonic 、 molding 、 PCBA dicing and manual soldering processes or customer's products are used in automotive system, the applicability should be confirmed with TXC R&D responsible person.
- (2) The green product standard set by TXC is based upon the international standards. Related information is publicly described on the TXC's Website, and updated regularly. The document is compliant with the latest green product quality system directives at the time.
- (3) Revision "Sx" is for engineering samples only. PE/RD's approval required.
- (4) Revision "Ax" is production ready. PE, QA and MFG's approval required.

MSL:Level 1
RoHS Compliant

(for glass crystal only : Pb used in sealing glass material is exempt from EU directive)



<u>Rev</u>	<u>Revise page</u>	<u>Revise contents</u>	<u>Date</u>	<u>Ref.No.</u>	<u>Reviser</u>
S1	N/A	Initial released	9-Jun-21	N/A	Anny Cheng
S2	2	Change supply voltage and phase jitter	2-Jul-21	PNR21062902	Anny Cheng

■ ELECTRICAL SPECIFICATIONS

Standard atmospheric conditions

Unless otherwise specified, the standard range of atmospheric conditions for making measurement and tests are as follow:

Ambient temperature : 25±5°C
 Relative humidity : 40%~70%

If there is any doubt about the results, measurement shall be made within the following limits:

Ambient temperature : 25±3°C
 Relative humidity : 40%~70%

Measure equipment

Electrical characteristics measured by MD 37WX-05M or equivalent.

Crystal cutting type

The crystal is using AT CUT (thickness shear mode).

Unit Weight:

0.015±0.002 g/pcs

	Parameters	Symbol	Electrical Spec.				Notes
			Min.	Typ.	Max.	Units	
1	Nominal Frequency	-	48.000000			MHz	-
2	Frequency Stability	-	±25			ppm	Note 1
3	Operating Temperature	Topr	-40	25	85	°C	-
4	Storage Temperature	Tstg	-55	~	125	°C	-
5	Supply Voltage	VDD	1.62	~	3.63	V	-
6	Input Current	Icc	-	-	15	mA	-
7	Enable Control	-	Yes			-	Pad 1
8	Output Load : CMOS	CL	15			pF	-
9	Output Voltage High	VoH	90%Vdd	-	-	V	-
10	Output Voltage Low	VoL	-	-	10%Vdd	V	-
11	Rise Time	Tr	-	-	5	ns	10%→90%VDD Level
12	Fall Time	Tf	-	-	5	ns	90%→10%VDD Level
13	Symmetry (Duty ratio)	TH/T	45	~	55	%	-
14	Start-up Time	Tosc	-	-	10	ms	-
15	Enable Voltage High	Vhi	70%Vdd	-	-	V	-
16	Disable Voltage Low	Vlo	-	-	30%Vdd	V	-
17	Aging	-	±3			ppm/yr.	1st. Year at 25°C
18	Output Disable Delay Time	T off	-	-	150	µs	-
19	Output Enable Delay Time	T on	-	-	300	µs	-
20	RMS Phase Jitter	-	-	-	0.15	ps	Integrated from 12KHz to 20MHz
22	Phase Noise	Pn	-	-90	-	dBc/Hz	@10Hz
		Pn	-	-125	-	dBc/Hz	@100Hz
		Pn	-	-140	-	dBc/Hz	@1KHz
		Pn	-	-150	-	dBc/Hz	@10KHz
		Pn	-	-165	-	dBc/Hz	@100KHz
		Pn	-	-165	-	dBc/Hz	@1MHz

Note 1 :Inclusive Initial Tolerance @ 25°C, Variation over Temperature, Supply Voltage, Load,Reflow and 10 Year Aging.

■ DIMENSIONS

(Unit:mm)

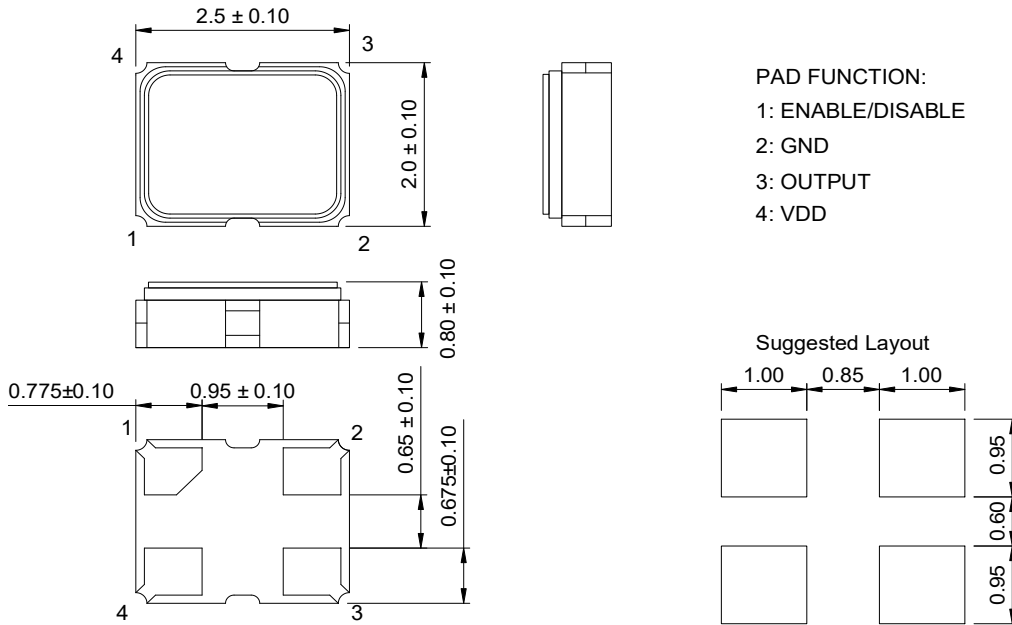

- PAD FUNCTION:
- 1: ENABLE/DISABLE
 - 2: GND
 - 3: OUTPUT
 - 4: VDD

■ MARKING

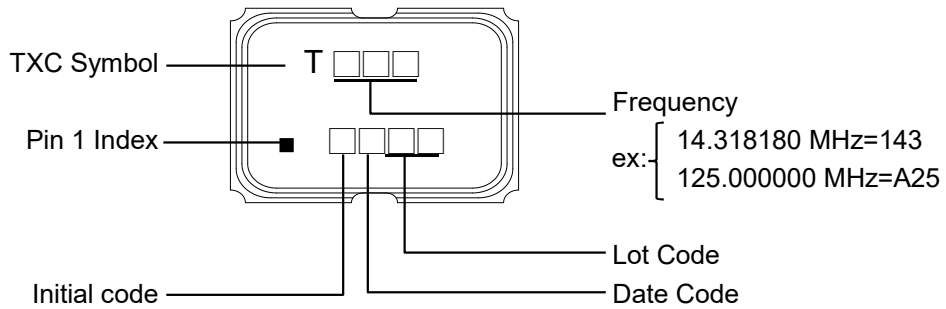

Date Code:

YEAR					MONTH											
					JAN	FEB	MAR	APR	MAY	JUN	JUL	AUG	SEP	OCT	NOV	DEC
2021	2025	2029	2033	2037	A	B	C	D	E	F	G	H	J	K	L	M
2022	2026	2030	2034	2038	N	P	Q	R	S	T	U	V	W	X	Y	Z
2023	2027	2031	2035	2039	a	b	c	d	e	f	g	h	j	k	l	m
2024	2028	2032	2036	2040	n	p	q	r	s	t	u	v	w	x	y	z

*This date code will be cycled every four years

TEST DIAGRAM

Pad 1 : Tri-State control

Pad 1(OE)	Pad 3 (Output)	Oscillator
High (or open)	OSC out	Normal operation
Low	High impedance	Stop oscillation

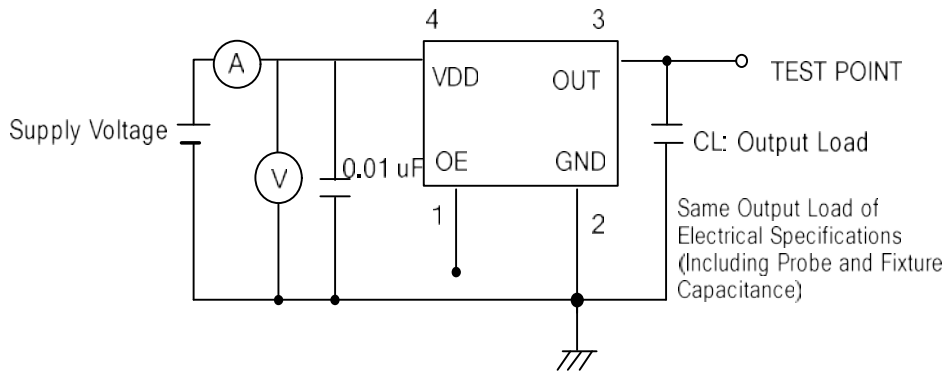

WAVEFORM CONDITIONS

Waveform measurement system should have a min. bandwidth of 5 times the frequency being tested.

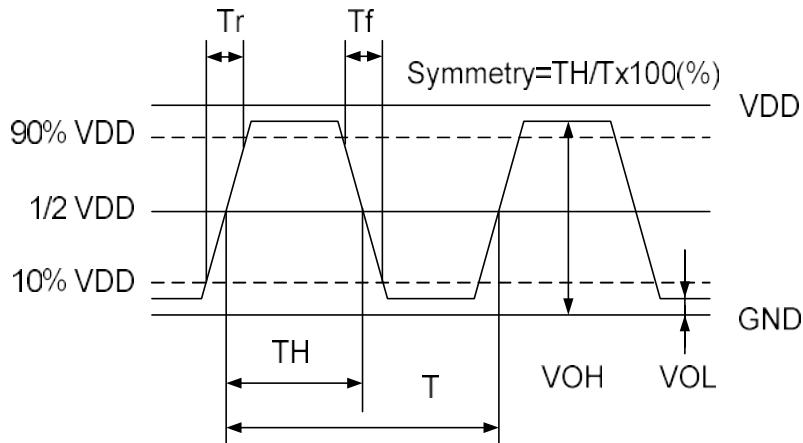

OUTPUT ENABLE / DISABLE DELAY

The following figure shows the oscillator timing during normal operation . Note that when the device is in standby, the oscillator stops. When standby is released, the oscillator starts and stable oscillator output occurs after a short delay.

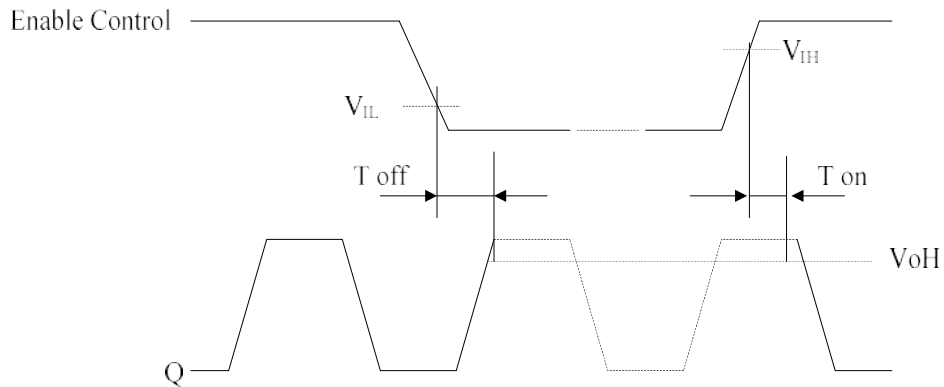

SUGGESTED REFLOW PROFILE

Total time : 600 sec. Max.

Solder melting point :220 °C

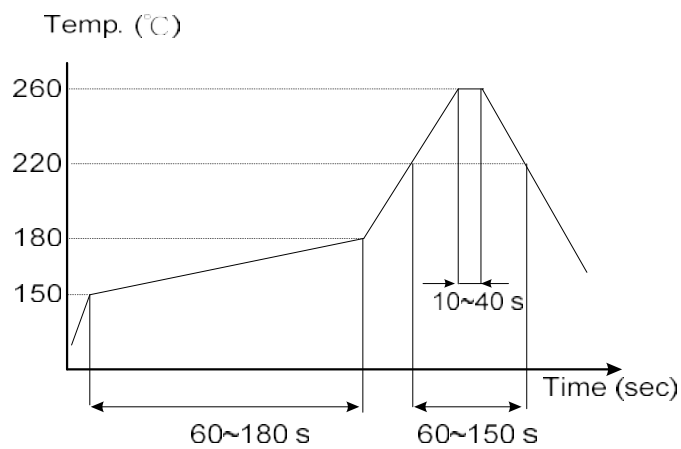

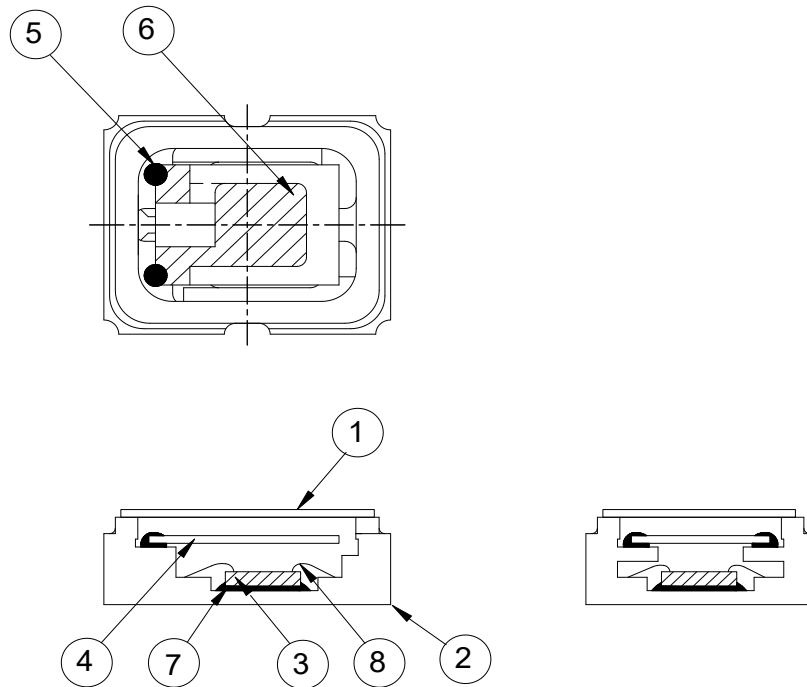
■ STRUCTURE ILLUSTRATION

NO	COMPONENTS	MATERIALS	FINISH/SPECIFICATIONS
1	Lid	Kovar (Fe/Co/Ni)	-
2	Base (Package)	Ceramic (Al ₂ O ₃) + Kovar (Fe/Co/Ni)+Pad(Au)	-
3	IC chip	-	-
4	Crystal blank	SiO ₂	-
5	Conductive adhesive	Ag	Silicon resin
6	Electrode	Noble Metal	-
7	Die attached	Epoxy	-
8	Bonding wire	Au	Pad 1 options : NC is 5 wires , EN is 6 wires.

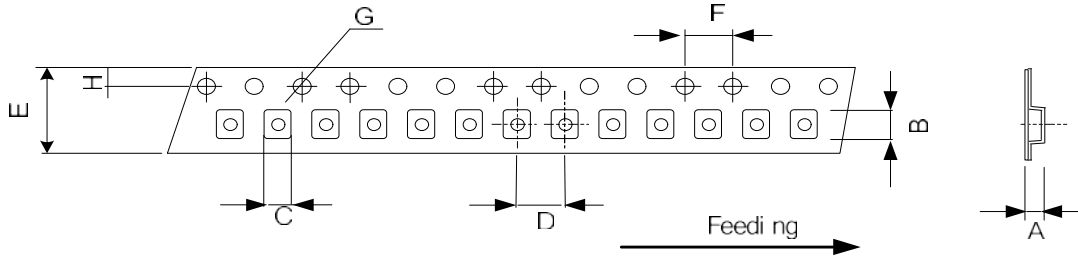
PACKING

DIMENSIONS	A	B	C	D	E	F	G	H	(UNIT:mm)
	1.15 ±0.05	2.70 ±0.05	2.25 ±0.05	4.00 ±0.10	8.00 ±0.20	4.00 ±0.10	1.55 ±0.05	1.75 ±0.10	

REMARK :

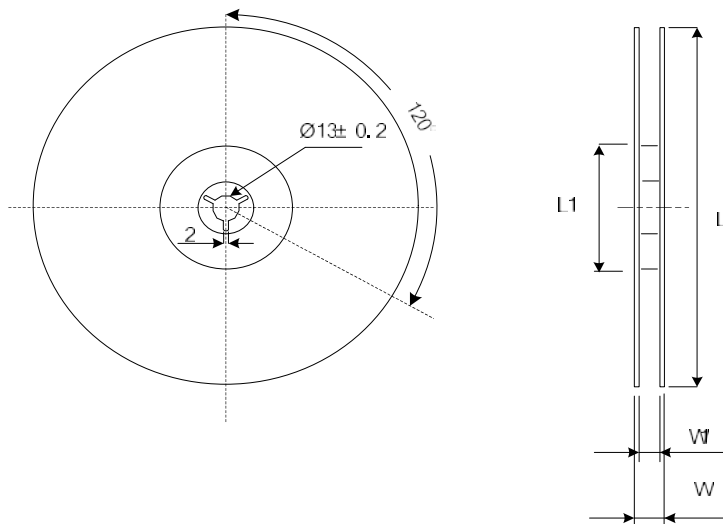
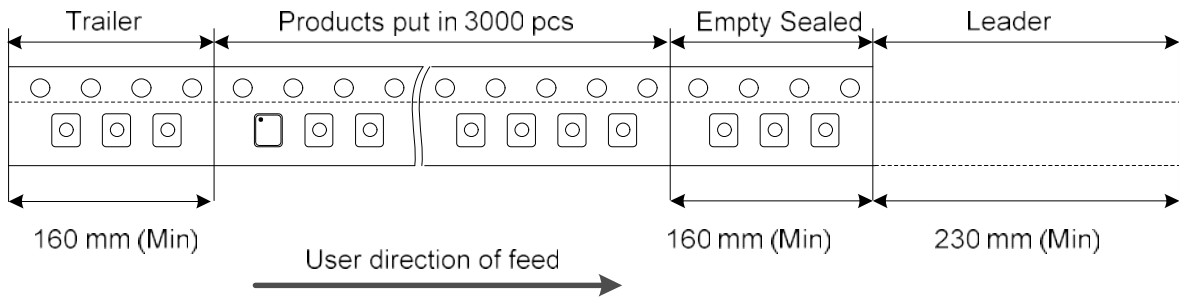

DIMENSIONS	L	L1	W	W1	Standard Reel Quantity is 3,000 pcs per reel (UNIT:mm)
	180 0/-3	60 +1/0	11.4 ±0.1	9 ±0.3	

RELIABILITY SPECIFICATIONS

1. Mechanical Endurance

No.	Test Item	Test Methods	REF. DOC
1.1	Drop Test	75 cm height, 3 times on concrete floor .	JIS C6701
1.2	Mechanical Shock	Device are shocked to half sine wave (1000 G) three mutually perpendicular axis each 3 times. 0.5m sec. duration time	MIL-STD-202
1.3	Vibration	Frequency range 10 ~ 2000 Hz Amplitude 1.52 mm/20G Sweep time 20 minute perpendicular axis each test time 4 Hrs (Total test time 12 Hrs)	MIL-STD-883
1.4	Gross Leak	Standard Sample For Automatic Gross Leak Detector, Test Pressure: 2kg / cm ²	MIL-STD-883
1.5	Fine Leak	Helium Bombing 4.5 kgf / cm ² for 2 Hrs	
1.6	Solderability	Temperature 245 °C ± 5°C Immersing depth 0.5 mm minimum Immersion time 5 ± 1 seconds Flux Rosin resin methyl alcohol solvent (1 : 4)	MIL-STD-883

2. Environmental Endurance

No.	Test Item	Test Methods	REF. DOC
2.1	Resistance To Soldering Heat	Pre-heat temperature 125 °C Pre-heat time 60 ~ 120 sec. Test temperature 260 ± 5 °C Test time 10 ± 1 sec.	MIL-STD-202
2.2	High Temp. Storage	+ 125 °C ± 3 °C for 1000 ± 12 Hrs	MIL-STD-883
2.3	Low Temp. Storage	- 40 °C ± 3 °C for 1000 ± 12 Hrs	
2.4	Thermal Shock	Total 100 cycles of the following temperature cycle 	MIL-STD-883
2.5	High Temp & Humidity	85°C ± 3°C, RH 85% , 1000 Hrs	EIA-JESD22
2.6	Pressure Cooker Storage	121 ± 3°C , RH100% , 2 bar , 240Hrs	EIA-JESD22