

EVAL-M7-D111T user guide

iMOTION™ evaluation board for smart driver

About this document

Scope and purpose

This user guide provides an overview of the evaluation board EVAL-M7-D111T, including its main features, key technical data, pin assignments, and dimensions.

EVAL-M7-D111T is an iMOTION™ application design kit based on Infineon's IMD111T smart driver IC. This board features and demonstrates Infineon's advanced motion control engine (MCE 2.0) technology for driving permanent magnet synchronous motors over the full speed range, combined with the fully integrated 3-phase high-voltage gate driver, and 5 V voltage regulator in a very compact 40-pin QFP package.

The evaluation board EVAL-M7-D111T was developed to help users in the first steps of application development with the running of permanent-magnet motors via sensorless, sinusoidal field-oriented control.

Intended audience

This evaluation board is intended for all technical specialists who are familiar with motor control and power electronics converter systems. It is intended for use under laboratory conditions.

Evaluation board

This board will be used during the design-in phase, for evaluating and measuring characteristics, and verifying data sheet specifications.

Note: PCB and auxiliary circuits are NOT optimized for final customer design.

Important notice

Important notice

“Evaluation Boards and Reference Boards” shall mean products embedded on a printed circuit board (PCB) for demonstration and/or evaluation purposes, which include, without limitation, demonstration, reference and evaluation boards, kits and design (collectively referred to as “Reference Board”).

Environmental conditions have been considered in the design of the Evaluation Boards and Reference Boards provided by Infineon Technologies. The design of the Evaluation Boards and Reference Boards has been tested by Infineon Technologies only as described in this document. The design is not qualified in terms of safety requirements, manufacturing and operation over the entire operating temperature range or lifetime.

The Evaluation Boards and Reference Boards provided by Infineon Technologies are subject to functional testing only under typical load conditions. Evaluation Boards and Reference Boards are not subject to the same procedures as regular products regarding returned material analysis (RMA), process change notification (PCN) and product discontinuation (PD).

Evaluation Boards and Reference Boards are not commercialized products, and are solely intended for evaluation and testing purposes. In particular, they shall not be used for reliability testing or production. The Evaluation Boards and Reference Boards may therefore not comply with CE or similar standards (including but not limited to the EMC Directive 2004/EC/108 and the EMC Act) and may not fulfill other requirements of the country in which they are operated by the customer. The customer shall ensure that all Evaluation Boards and Reference Boards will be handled in a way which is compliant with the relevant requirements and standards of the country in which they are operated.

The Evaluation Boards and Reference Boards as well as the information provided in this document are addressed only to qualified and skilled technical staff, for laboratory usage, and shall be used and managed according to the terms and conditions set forth in this document and in other related documentation supplied with the respective Evaluation Board or Reference Board.

It is the responsibility of the customer’s technical departments to evaluate the suitability of the Evaluation Boards and Reference Boards for the intended application, and to evaluate the completeness and correctness of the information provided in this document with respect to such application.

The customer is obliged to ensure that the use of the Evaluation Boards and Reference Boards does not cause any harm to persons or third party property.

The Evaluation Boards and Reference Boards and any information in this document is provided "as is" and Infineon Technologies disclaims any warranties, express or implied, including but not limited to warranties of non-infringement of third party rights and implied warranties of fitness for any purpose, or for merchantability.

Infineon Technologies shall not be responsible for any damages resulting from the use of the Evaluation Boards and Reference Boards and/or from any information provided in this document. The customer is obliged to defend, indemnify and hold Infineon Technologies harmless from and against any claims or damages arising out of or resulting from any use thereof.

Infineon Technologies reserves the right to modify this document and/or any information provided herein at any time without further notice.

Safety precautions

Safety precautions

Note: Please note the following warnings regarding the hazards associated with development systems.

Table 1 Safety precautions

	<p>Warning: The DC link potential of this board is up to 1000 V_{DC}. When measuring voltage waveforms by oscilloscope, high voltage differential probes must be used. Failure to do so may result in personal injury or death.</p>
	<p>Warning: The evaluation or reference board contains DC bus capacitors which take time to discharge after removal of the main supply. Before working on the drive system, wait five minutes for capacitors to discharge to safe voltage levels. Failure to do so may result in personal injury or death. Darkened display LEDs are not an indication that capacitors have discharged to safe voltage levels.</p>
	<p>Warning: The evaluation or reference board is connected to the grid input during testing. Hence, high-voltage differential probes must be used when measuring voltage waveforms by oscilloscope. Failure to do so may result in personal injury or death. Darkened display LEDs are not an indication that capacitors have discharged to safe voltage levels.</p>
	<p>Warning: Remove or disconnect power from the drive before you disconnect or reconnect wires, or perform maintenance work. Wait five minutes after removing power to discharge the bus capacitors. Do not attempt to service the drive until the bus capacitors have discharged to zero. Failure to do so may result in personal injury or death.</p>
	<p>Caution: The heat sink and device surfaces of the evaluation or reference board may become hot during testing. Hence, necessary precautions are required while handling the board. Failure to comply may cause injury.</p>
	<p>Caution: Only personnel familiar with the drive, power electronics and associated machinery should plan, install, commission and subsequently service the system. Failure to comply may result in personal injury and/or equipment damage.</p>
	<p>Caution: The evaluation or reference board contains parts and assemblies sensitive to electrostatic discharge (ESD). Electrostatic control precautions are required when installing, testing, servicing or repairing the assembly. Component damage may result if ESD control procedures are not followed. If you are not familiar with electrostatic control procedures, refer to the applicable ESD protection handbooks and guidelines.</p>
	<p>Caution: A drive that is incorrectly applied or installed can lead to component damage or reduction in product lifetime. Wiring or application errors such as undersizing the motor, supplying an incorrect or inadequate AC supply, or excessive ambient temperatures may result in system malfunction.</p>
	<p>Caution: The evaluation or reference board is shipped with packing materials that need to be removed prior to installation. Failure to remove all packing materials that are unnecessary for system installation may result in overheating or abnormal operating conditions.</p>

Table of contents

About this document	1
Important notice	2
Safety precautions	3
Table of contents	4
1 The board at a glance	5
1.1 Scope of supply	6
1.2 Block diagram.....	6
1.3 Main features	7
1.4 Board parameters and technical data	7
2 System and functional description	8
2.1 Commissioning.....	8
2.1.1 Setting up the system	8
2.1.2 iMOTION™ development tools and software	9
2.1.2.1 MCEWizard setup overview.....	9
2.1.2.2 MCEDesigner setup overview	11
2.2 Description of the functional blocks.....	12
2.2.1 Eval-M7-D111T pinout assignment and functional groups	12
2.2.2 Current feedback circuitry	15
2.2.2.1 Shunt configuration and current sampling.....	15
2.2.2.2 Offset voltage calculation	16
3 System design	17
3.1 Schematics	17
3.2 Layout	17
3.3 Bill of material	19
4 System performance	20
4.1 Test results	20
5 Ordering details and other information	22
6 References and appendices	23
6.1 References	23
Revision history	23

The board at a glance

1 The board at a glance

The EVAL-M7-D111T evaluation board is an iMOTION™ smart-driver application design kit for small motor drives. It can be used to run M7 connector-compatible power boards, such as Infineon MADK boards, EVAL-M7-HVIGBT-INV, EVAL-M7-HVMOS-INV, and EVAL-M7-LVMOS-INV. Of course, other power boards which are M7 connector-compatible can also be used for different power stages. The board is a complete system-control evaluation board including a 5 V power supply output and 3-phase motor drive PWM output.

The main device on the evaluation board is the iMOTION™ smart driver IC IMD111T. This device is a highly integrated IC for the control of variable speed drives that includes a motor control processor, a high-voltage three-phase gate driver, and a 5 V voltage regulator. The IMD111T is capable of controlling the PMSM/BLDC (permanent magnet synchronous motor/brushless direct current motor) motors using sensorless or sensed rotor angle and speed feedback. The target applications include home appliances, fans, pumps, etc. The system enables a rapid configuration and a quick motor system setup, start-up and tuning by using the iMOTION™ MCEWizard and MCEDesigner software tools. The key features and functionality of this board are described in Chapter 1.3 with the main features of this document (UG-2021-17). The remaining chapters provide information on how to set up and use this evaluation board, and how to copy and/or modify the design according to specific user requirements.

Figure 1 depicts the evaluation board EVAL-M7-D111T. This document describes the features and design of the board and of the smart driver IMD111T.

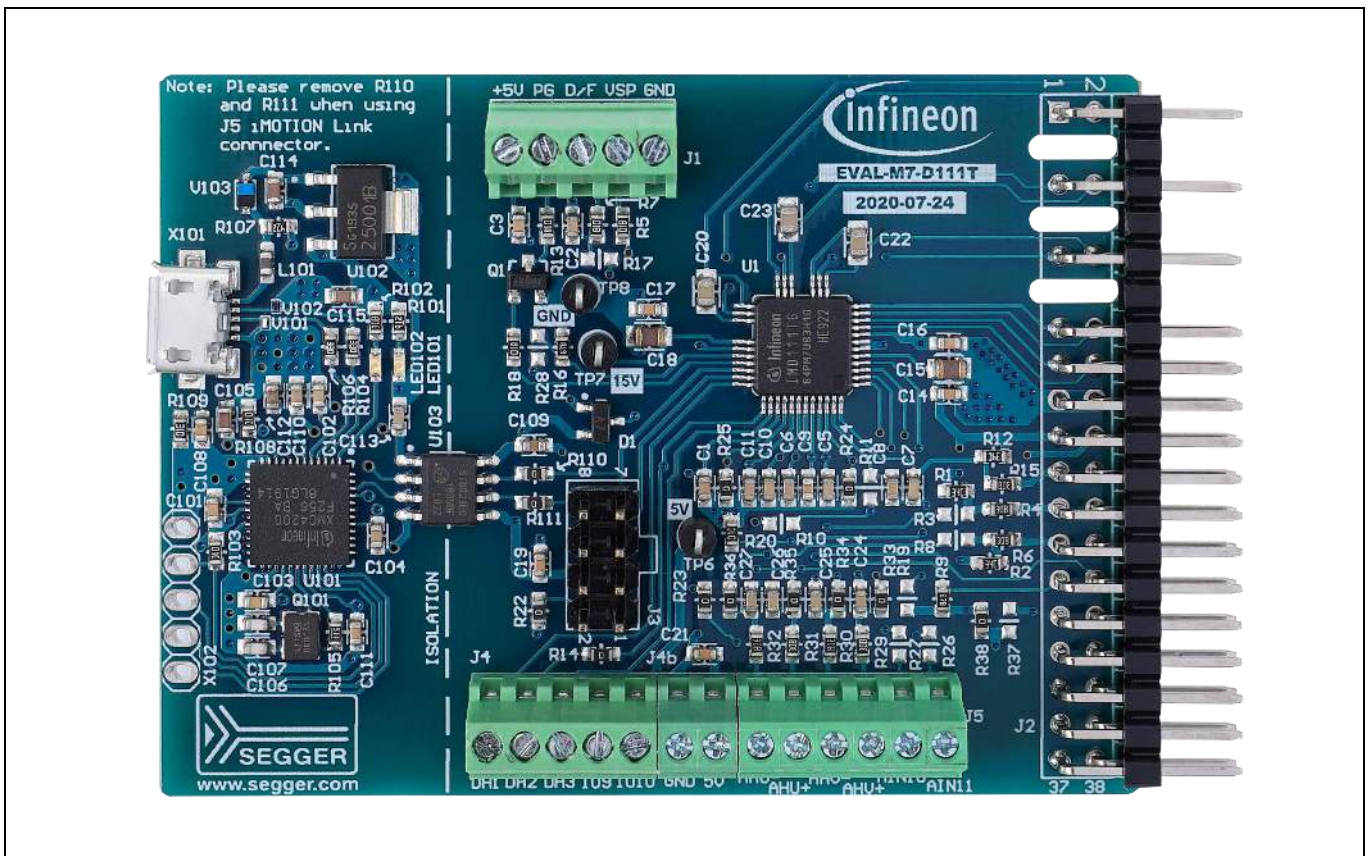

Figure 1 Evaluation board of EVAL-M7-IMD111T

The board at a glance

1.1 Scope of supply

The scope of supply comprises only the board, as shown in Figure 1. The detailed ordering information is indicated in Table 2.

A USB cable, as shown in Figure 3, is mandatory for tuning, but it is not included in the delivery content. The iMOTION™ link connector on the board is an optional tuning method for users who want to tune the board via the iMOTION™ link isolated debug probe. Please order this if you do not have it; ordering information can be found in the following [link](#).

Table 2

Base part number	Package	Standard pack		Orderable part number
		Form	Quantity	
EVAL-M7-D111T		Boxed	1	SP004177776
IMD111T-6F040		Taped		
iMOTION™ link		Boxed	1	SP001780380

1.2 Block diagram

Figure 2 shows the block diagram of EVAL-M7-D111T and connections with the power stage. EVAL-M7-D111T is a control board for motor control with sensorless or rotor angle and speed feedback. IMD111T includes a 3-phase high-voltage gate driver, and a 5 V voltage regulator.

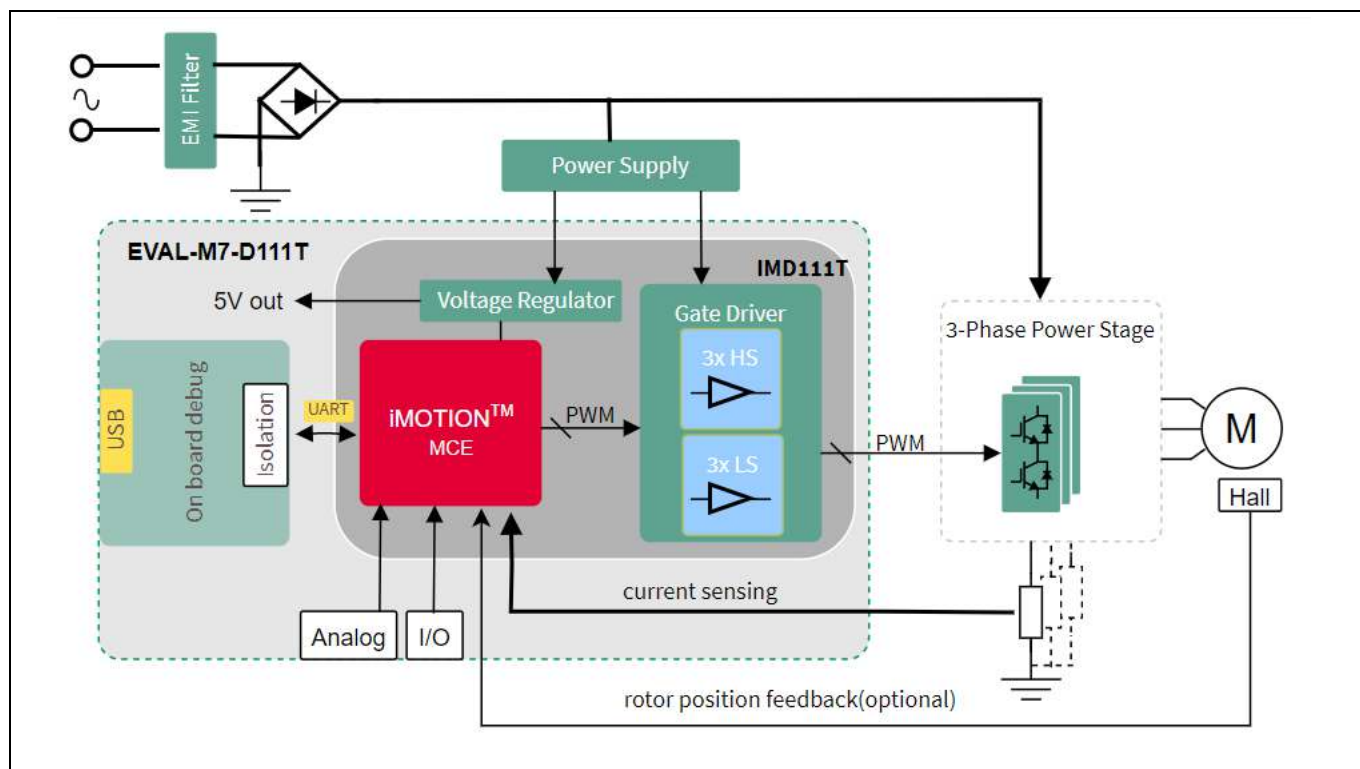

Figure 2 EVAL-M7-IMD111T block diagram

The board at a glance

1.3 Main features

EVAL-M7-D111T is an evaluation board using Infineon’s IMD111T smart driver. This board is suitable for PMSM or BLDC motor control for home appliances, fans, pumps, etc.

The main features of the IMD111T smart driver include:

- Motor controller with integrated high-voltage gate driver and voltage regulator
- Integrated 5 V low dropout linear voltage regulators (LDO) allows single 15 V supply voltage
- Robust 600 V gate driver in thin-film, silicon-on-insulator (SOI) technology
- Gate driver integrated with ultra-fast bootstrap diodes
- Space-saving 40-pin low-profile quad flat package (LQFP) with high-voltage creepage
- Motion control engine (MCE) as ready-to-use solution for variable speed drives
- Sensorless field-oriented control (FOC) for permanent magnet synchronous motor (PMSM)
- Flexible space vector pulse width modulation (PWM), include 3-phase PWM or 2-phase PWM
- Motor current sensing via single or leg shunt
- Optional analog or digital Hall sensor interface
- Flexible host interface options for motor control commands: UART, frequency/duty cycle or Analog VSP
- IEC60335-1/UL60730 Class B safety software certificate

The main features of the EVAL-M7-D111T evaluation board include:

- On-board debug included on the board
- iMOTION™ link connector is an optional communication interface
- Single shunt or leg shunt current feedback configuration are alternatives
- VSP or duty/frequency control is optional
- PCB size is 51 mm x 77 mm, 2 layers, 1 oz copper
- RoHS-compliant

1.4 Board parameters and technical data

Table 3 depicts the evaluation board parameters and technical details.

Table 3 Board specification

Parameter	Symbol	Conditions	Value	Unit
Input 15 V voltage	+15 V	Maximum 60 mA output current	15±5%	V
5 V output voltage	+5 V	Maximum 20 mA output current	5±5%	V
Communication				
Mini USB	X101	On-board debug incorporated	UART1	
iMOTION™ link	J3	iMOTION™ link isolated debug probe must be used	UART1	
PCB characteristics				
Material		1.6 mm thickness, 1 oz copper, 2 layers	FR4	
Dimensions		Length × width × height	77 × 51 × 14	mm
System environment				
Ambient temperature	T _{amb}	Non-condensing, maximum RH 95%	0 ~ 50	°C

2 System and functional description

2.1 Commissioning

2.1.1 Setting up the system

After downloading and installing the iMOTION™ development tools (MCEWizard and MCEDesigner), the following steps need to be executed to run the motor. Refer to Chapters 2.1.2.1 and 2.1.2.2 as well as to the MCEWizard and MCEDesigner user guide for more information.

1. Get the latest “IMD111T Software Package” available on the www.infineon.com/imotion-software website.
2. Connect PC and evaluation board via USB cable or iMOTION™ link.
3. Connect the AC source and target motor.
4. Use MCEWizard to calculate and create a parameter text file. See chapter MCEWizard setup overview of Chapter 2.1.2.1 for more details.
5. Power-on the system and start MCEDesigner tool to open MCEDesigner default configuration file (.irc) for IMD111T smart driver.
6. Program the firmware and calculated parameters into the flash. See chapter on MCEDesigner setup overview of Chapter 2.1.2.2 for more details.
7. After programming successfully, click on the hammer icon to clear the fault signals if there is a red light at the bottom of MCEDesigner. When the entire system is ready, start the motor by clicking the green traffic light. Clicking the red traffic light stops the motor.

Figure 3 is an example of the system setup. The control board is EVAL-M7-D111T and power board is EVAL-M7-HVIGBT-PFCINV.

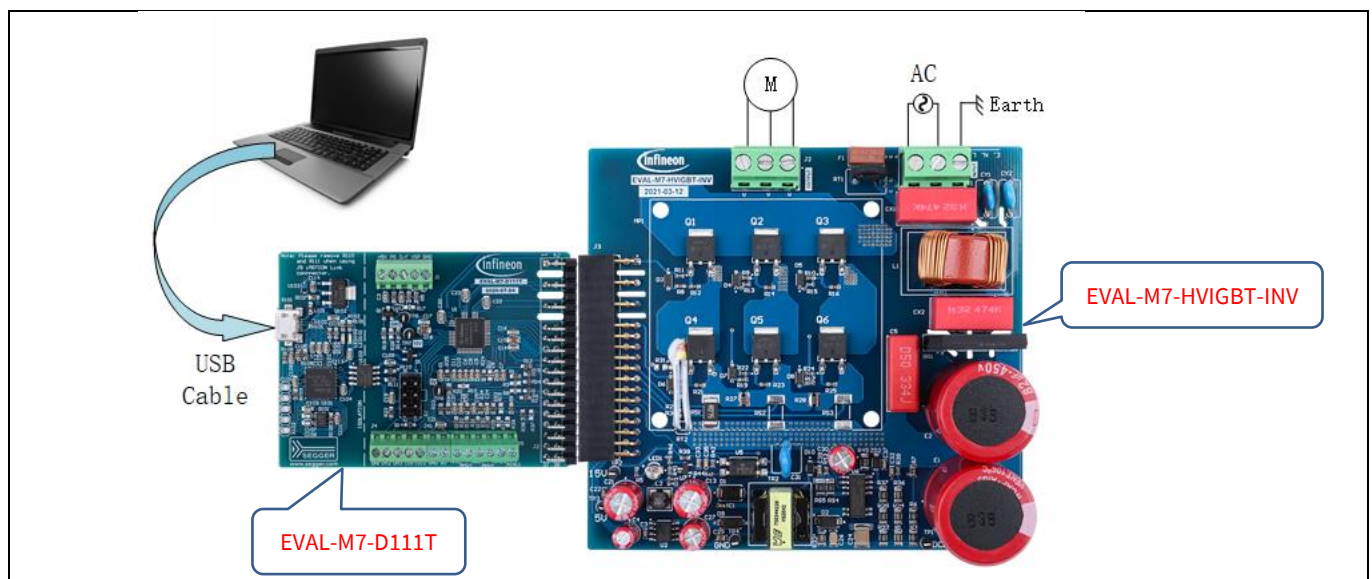

Figure 3 System setup example

2.1.2 iMOTION™ development tools and software

When users want to test and evaluate this board, they need to calculate the variable parameters with their motor via MCEWizard. Then they can use the MCEDesigner to tune the motor. For this, the iMOTION™ development tool has to be installed on the computer. The tool can be downloaded from the Infineon website; the quick link is included [here](#). Users can also find the related firmware IMD111T MCE software package on this webpage. The iMOTION™ development tool includes MCEWizard and MCEDesigner. The MCEWizard calculates the parameters of the firmware needed, and the MCEDesigner programs the parameters into flash, and does the tuning. Two shortcut icons will appear on the Windows desktop after installing is finished.

Note: Please note that the iMOTION™ development tools described here are based on the version V2.3. Some features may vary according to the different versions. Please also refer to the relevant version of the user guide of MCEWizard or MCEDesigner.

2.1.2.1 MCEWizard setup overview

MCEWizard defines control gains, limits and fault levels based on real number inputs, and converts gains and levels to parameter counts based on hardware and control limit settings. MCEWizard also exports parameters and variable scale factors to the MCEDesigner.

- Double-click the MCEWizard shortcut on Windows desktop, the MCEWizard welcome page is shown as in Figure 4.
- If users have the evaluation design kit MCEWizard configuration file, they only need to click the “Open System Configuration File” button and changes the user’s motor parameters under test.
- But if users do not have this evaluation design kit MCEWizard configuration file, they need to click the button “File” and select “Create System Configuration File”. Then follow the pop-up window prompt to complete the configuration step by step.
- For this evaluation board, if users do not have the MCEWizard configuration file, they should click “File” and select “Create System Configuration File”, then select the IMD111T device in the pop-up window. Next, click OK and return to the welcome page, then select “Customized Design for Expert User”. Click the Next button to answer all the questions concerning the hardware design and user test motor specification.

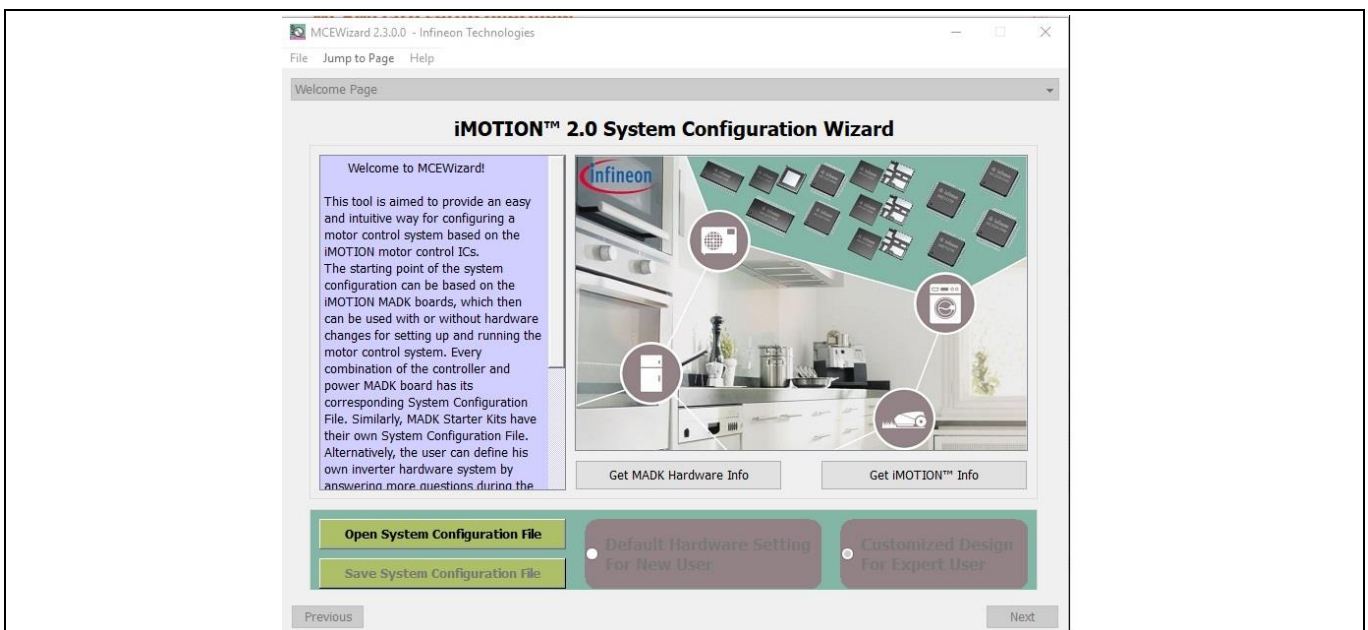

Figure 4 MCEWizard welcome page

System and functional description

Table 4 lists key questions which need to be answered in the MCEWizard in order to set up the system based on the evaluation board. The remaining group of questions also need to be answered (such as OV/UV protection, fault conditions, startup setting, etc.)

Table 4 MCEWizard setup overview table

Parameter	Value	Comment
Motor1 PWM frequency, current sensing configuration and control input on Option page	Fc<20 kHz, UART/VSP/duty/frequency Single/leg-shunt configuration	Key for selecting IC working status
User motor parameters	Depends on the motor under test	Such as rated current, poles Lq, Ld, maximum RPM, etc.
DC bus sensing high resistor	2000 kΩ on board	These resistors are on the power board.
DC bus sensing low resistor	12.7 kΩ on board	The resistor is on the power board.
Motor current input scaling	68.8 mV/A	Depends on hardware design, single-shunt configuration
Current input to ADC offset voltage	274 mV	Depends on hardware design
Overcurrent trip level	1.23 A	Depends on rated current of power board and motor
Catch spin	Enable/disable	

After answering all the questions, users will go to the “Verify & Save Page” (see Figure 5). On that page, users need to click the “Calculate Parameters” button to create the parameters. Then they can click the “Export to MCEDesigner File” button to export and save the parameter text file.

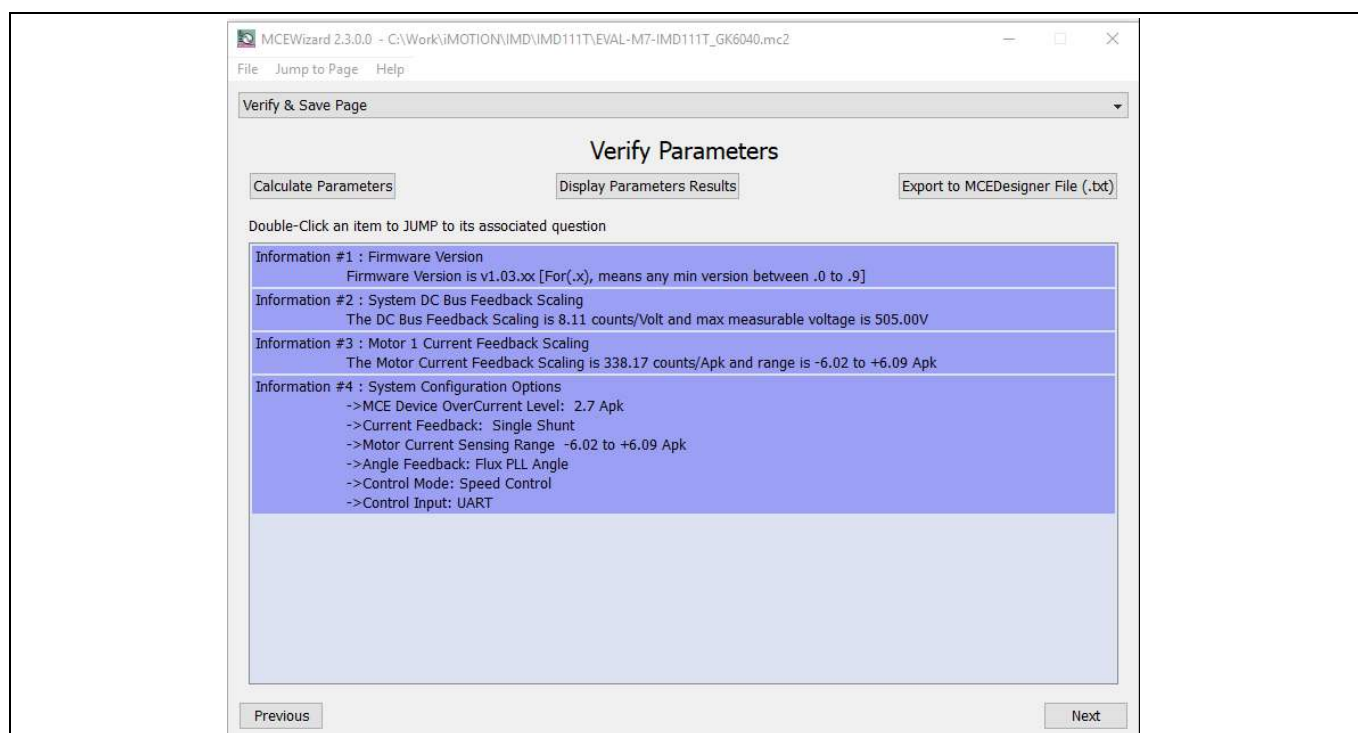

Figure 5 Verify & Save page of MCEWizard

2.1.2.2 MCEDesigner setup overview

MCEDesigner is a tool that can be used for programming code and tuning the evaluation board, including the possibility to read from 16-bit MCE variable registers, and to read/write to MCE parameter registers. MCEDesigner displays both real and counts value for all variable registers, and selects parameter registers. The count value means to convert the real value to digital number. The registers' value format can be selected from “Performance > Tuning Value Format” pop-up window.

After installing the MCEDesigner installer, there will be a shortcut on the Windows desktop. A quick start of MCEDesigner is as following two steps:

- Double-click on the shortcut to open MCEDesigner.
- Open the MCEDesigner default configuration file (.irc) for IMD111T smart driver (IMD111T_V1.03.01.irc included in the firmware zip folder downloaded from the Infineon website).
- Select the available COM port in “Performance > Connection” pop-up window

The MCEDesigner window appears as shown in Figure 6.

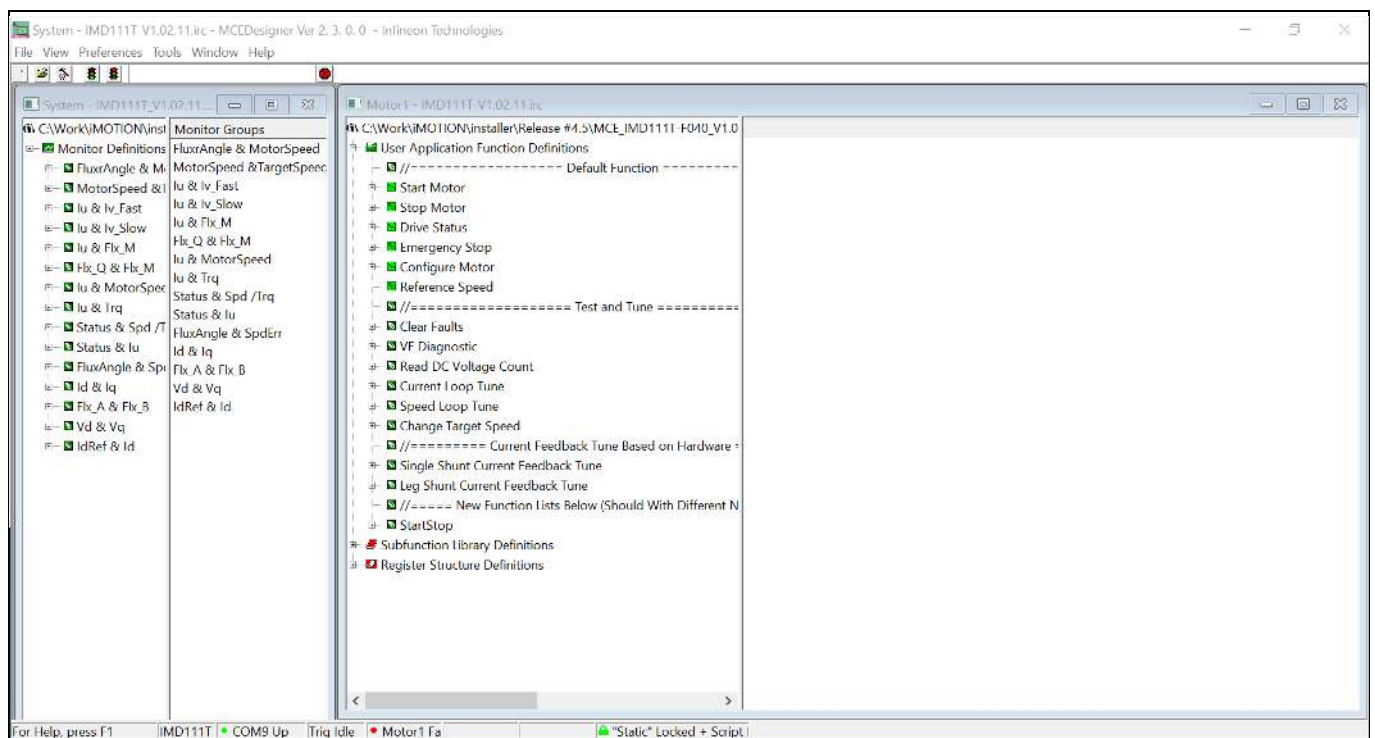

Figure 6 MCEDesigner window page

For the next step, the users need to program the firmware (.ldf file) and parameters (.txt file) into flash.

- Please click on the “Tools” menu in the “System” window and select “Programmer” from the pull-down list.
- Choose the relevant ldf file and text file,
- Then click the Start button to program the ldf and text files.

The ldf file can be downloaded from the Infineon website. The txt file was created by the MCEWizard as described in Chapter 2.1.2.1. The programming window is shown in Figure 7 below.

EVAL-M7-D111T user guide

iMOTION™ evaluation board for smart driver

System and functional description

After firmware and parameters are programmed, the system will be ready to run the motor. Users can click the green traffic light to start the motor or click the red traffic light to stop the motor. Users can now check the waveform of phase current, Flx_M, motor speed, and other registers' values when they double-click the monitor items in the system window.

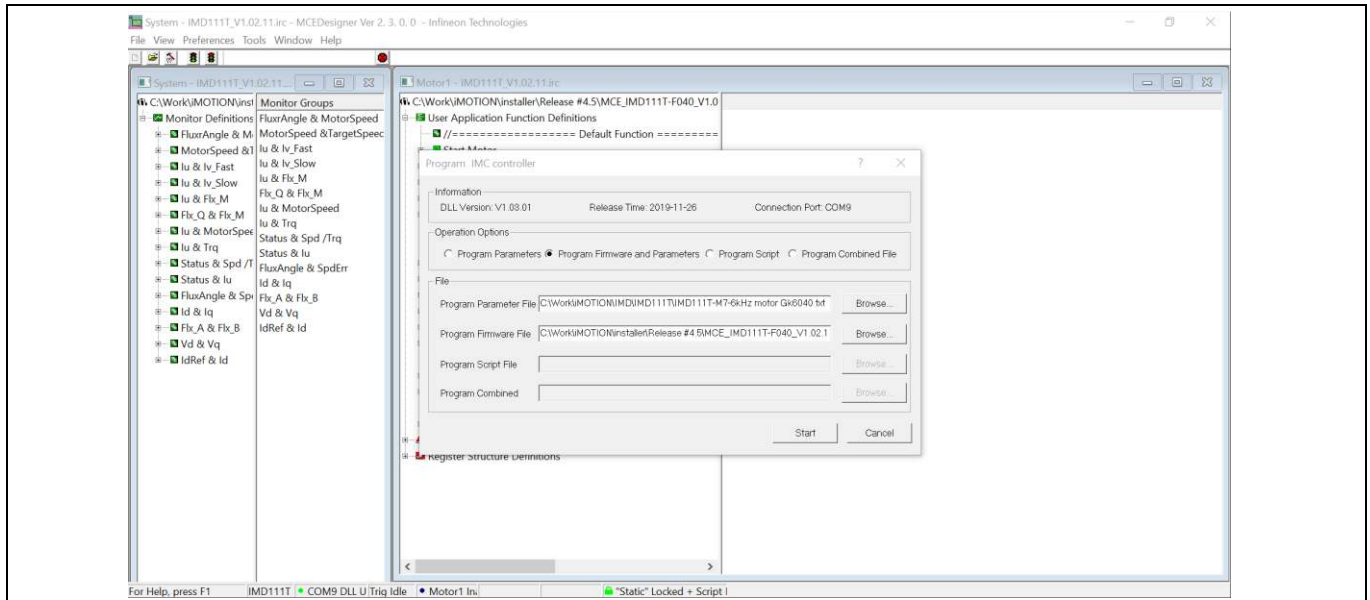

Figure 7 Programming window

2.2 Description of the functional blocks

This chapter covers the hardware design of the EVAL-M7-D111T in more detail. Users can understand some key circuitry in this application. So they can easily use MCEWizard to calculate the parameters. And it is also helpful for users to develop their solution based on the evaluation board design.

2.2.1 Eval-M7-D111T pinout assignment and functional groups

Figure 8 points out the evaluation board of EVAL-M7-D111T pinout assignment and functional group.

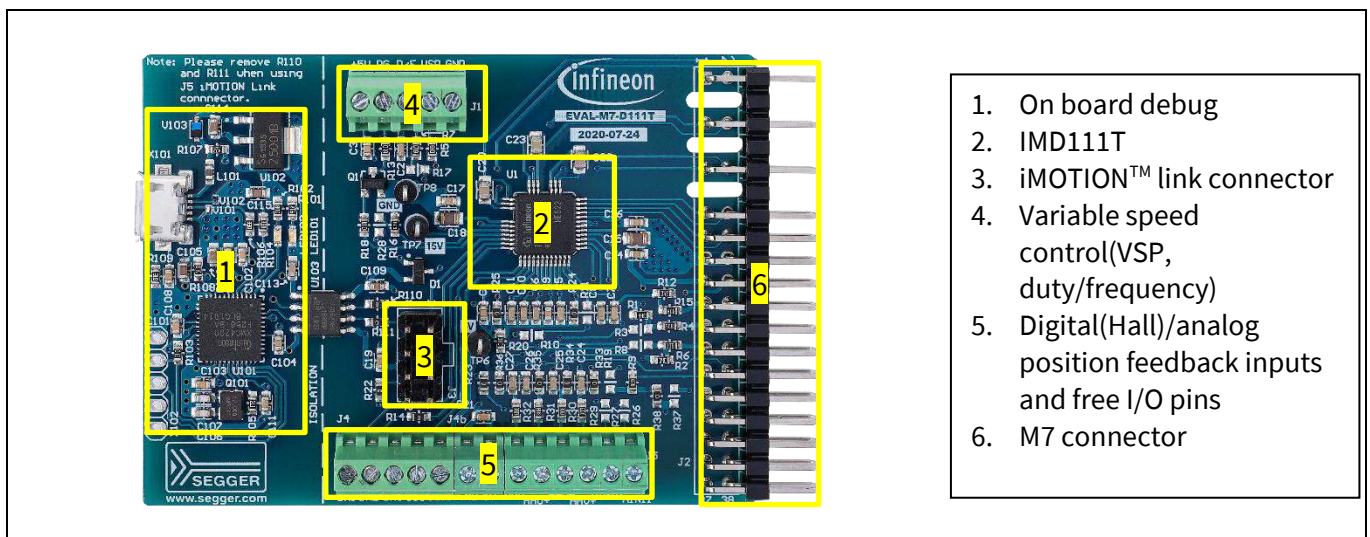

1. On board debug
2. IMD111T
3. iMOTION™ link connector
4. Variable speed control(VSP, duty/frequency)
5. Digital(Hall)/analog position feedback inputs and free I/O pins
6. M7 connector

Figure 8 Pinout assignment and functional groups

System and functional description

The main controller is IMD111T on the board. The IMD111T pinout diagram is described in Figure 9 below. Please refer to IMD111T datasheet for the details.

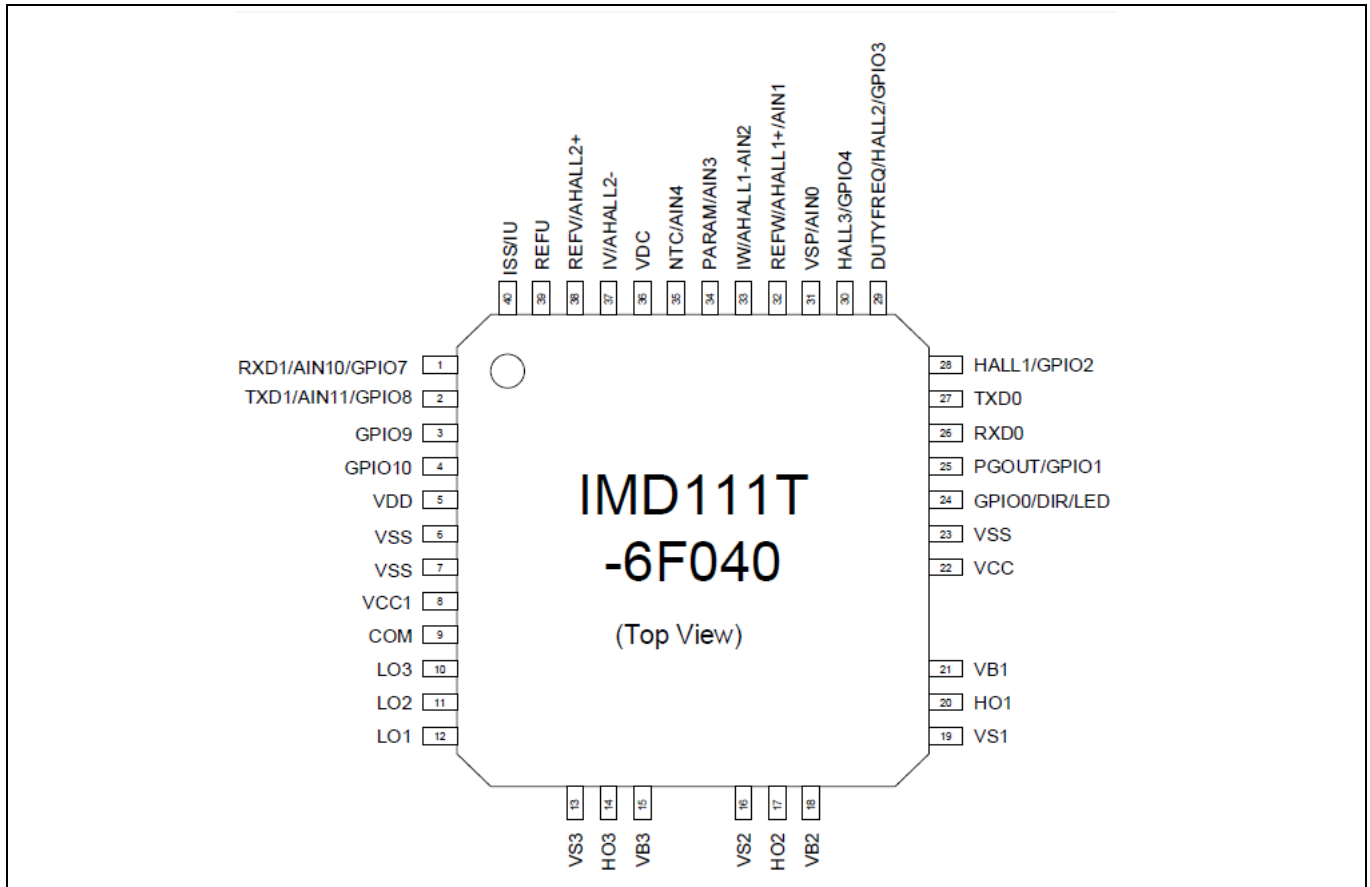

Figure 9 **IMD111T pinout**

There are several connectors on the EVAL-M7-D111T board. All connector pin assignments are described in Table 5~Table 9.

Table 5 **Variable speed control connector-J1**

Pin Number	Symbol	Assignment
1	GND	Signal return
2	VSP	Voltage speed control input
3	D/F	Duty/frequency speed control input
4	PG	Speed feedback output
5	+5V	5 V power supply

Table 6 M7 connector-J2

Pin Number	Symbol	Assignment
1	GUH	U phase high-side gate PWM
2	VSV	U phase high-side floating return
3, 4, 7, 8, 11, 12	-	Not used.
5	GVH	V phase high-side gate PWM
6	VSV	V phase high-side floating return
9	GWH	W phase high-side gate PWM
10	VSW	W phase high-side floating return
13	GUL	U phase low-side gate PWM
14	GVL	V phase low-side gate PWM
15	GWL	W phase low-side gate PWM
16	COM	Gate driver low-side return
17, 18, 32	GND	Ground
19	VDD	Internal LDO output
20	VDD1	External VDD supply voltage
21	IU+	U phase current-sensing signal positive
22	IU-	U phase current-sensing signal negative
23	IV+	V phase current-sensing signal positive
24	IV-	V phase current-sensing signal negative
25	IW+	W phase current-sensing signal positive
26	IW-	W phase current-sensing signal negative
27	VTH	NTC output voltage
28	VDC	V _{bus} voltage sensing
29	GK	inverter gate kill signal
30	VCC	Gate driver supply voltage
31	PFCG0	PFC gate driving PWM 0 (not used for this board)
33	PFCG1	PFC gate driving PWM 1 (not used for this board)
34	PFCGK	PFC gate kill signal (not used for this board)
35	IPFC+	PFC current-sensing positive (not used for this board)
36	IPFC-	PFC current-sensing negative (not used for this board)
37	VAC1	AC voltage-sensing input 1 (not used for this board)
38	VAC2	AC voltage-sensing input 2 (not used for this board)

Table 7 iMOTION™ link connector-J3

Pin Number	Symbol	Assignment
1	TXD1	Serial port 1, transmit output
2	RXD1	Serial port 1, receive input
3	VDD	5 V power supply
4	GND	Ground
5	GND	Ground
6	VDD	5 V power supply
7	RXD0	Serial port 0, receive input
8	TXD0	Serial port 0, transmit output

Table 8 Digital hall feedback & GPIO connector-J4

Pin Number	Symbol	Assignment
1	DH1	Digital hall sensor input 1
2	DH2	Digital hall sensor input 2
3	DH3	Digital hall sensor input 3
4	GPIO9	Digital I/O
5	GPIO10	Digital I/O

Table 9 Analog position feedback & analog signal input connector-J5

Pin Number	Symbol	Assignment
1	AHU+	Analog Hall element input 1 (+)
2	AHU-	Analog Hall element input 1 (-)
3	AHV+	Analog Hall element input 2 (+)
4	AHV-	Analog Hall element input 2 (-)
5	AIN10	Analog signal input
6	AIN11	Analog signal input

2.2.2 Current feedback circuitry

2.2.2.1 Shunt configuration and current sampling

For the IMD111T, there are two options of current feedback circuitry. One is the single-shunt current feedback configuration. The other is the leg-shunt current feedback configuration. Single shunt is the default setting for current feedback on the EVAL-M7-D111T board. If users want to use leg-shunt configuration, please refer to the selection table in the schematics for the details.

Figure 10 depicts the block diagram of the current feedback offset and gain. The current input scaling is a key parameter value that needs to be calculated and entered into MCEWizard. This parameter is the gain of the external current single/leg-shunt measurement circuit. The value is the product of the shunt resistance in milliohms, and the AC gain of the offset and gains circuit. The calculation equation is as follows:

$$\text{Current input scaling} = G_{ext} \times R_s$$

In the example circuit, the gain calculated from the analysis with $R_s \approx 0$, is given by:

$$G_{ext} = \frac{R2}{R1 + R2}$$

So the current input scaling can be calculated as:

$$\text{Current input scaling} = G_{ext} \times R_s = \frac{R2}{R1 + R2} \times R_s$$

For this evaluation board's inverter current feedback circuit, the $R1$ is 2 k Ω , $R2$ is 22.1 k Ω , and the R_s is 75 m Ω . So the inverter current input scaling can be calculated as 68.8 mA/V.

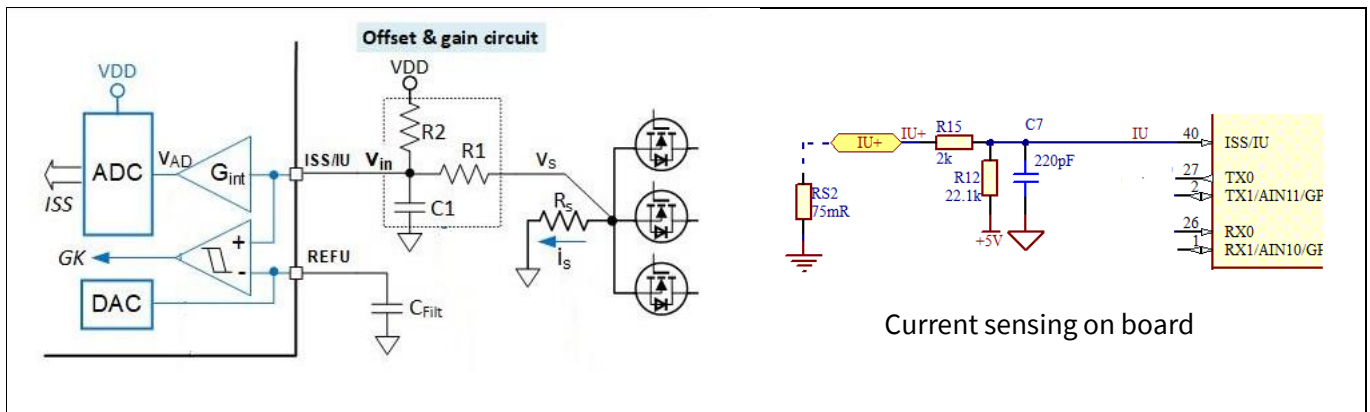

Figure 10 Current feedback offset and gain

2.2.2.2 Offset voltage calculation

We can conclude from Figure 10 that users can also calculate the offset voltage needed to enter into MCEWizard. This parameter is the voltage in mV at the current sense pin when the shunt current is zero. In the evaluation board design example, $R1$ is 2 k Ω and $R2$ is 22.1 k Ω . So the offset voltage is:

$$V_{off} = \frac{R1}{R1 + R2} \times VDD = \frac{2}{2 + 22.1} \times 5 = 0.415 V = 415 mV$$

System design

3 System design

3.1 Schematics

The schematics of the IMD111T control board EVAL-M7-D111T include terminals for digital Hall-feedback inputs and analog position-feedback inputs. There is an on-board debug circuit on the control board that prompts users to tune the board via a USB cable. The on-board debug circuit has an isolation function between computer USB port and IMD111T control board. An optional communication interface on the board is the iMOTION™ link connector (J3). The two resistors R110 and R111 should be removed when using the iMOTION™ link debug tool.

Figure 11 shows the smart driver IMD111T schematics. The complete schematic diagrams are available on the download section of the Infineon homepage. A log-in is required to download this material.

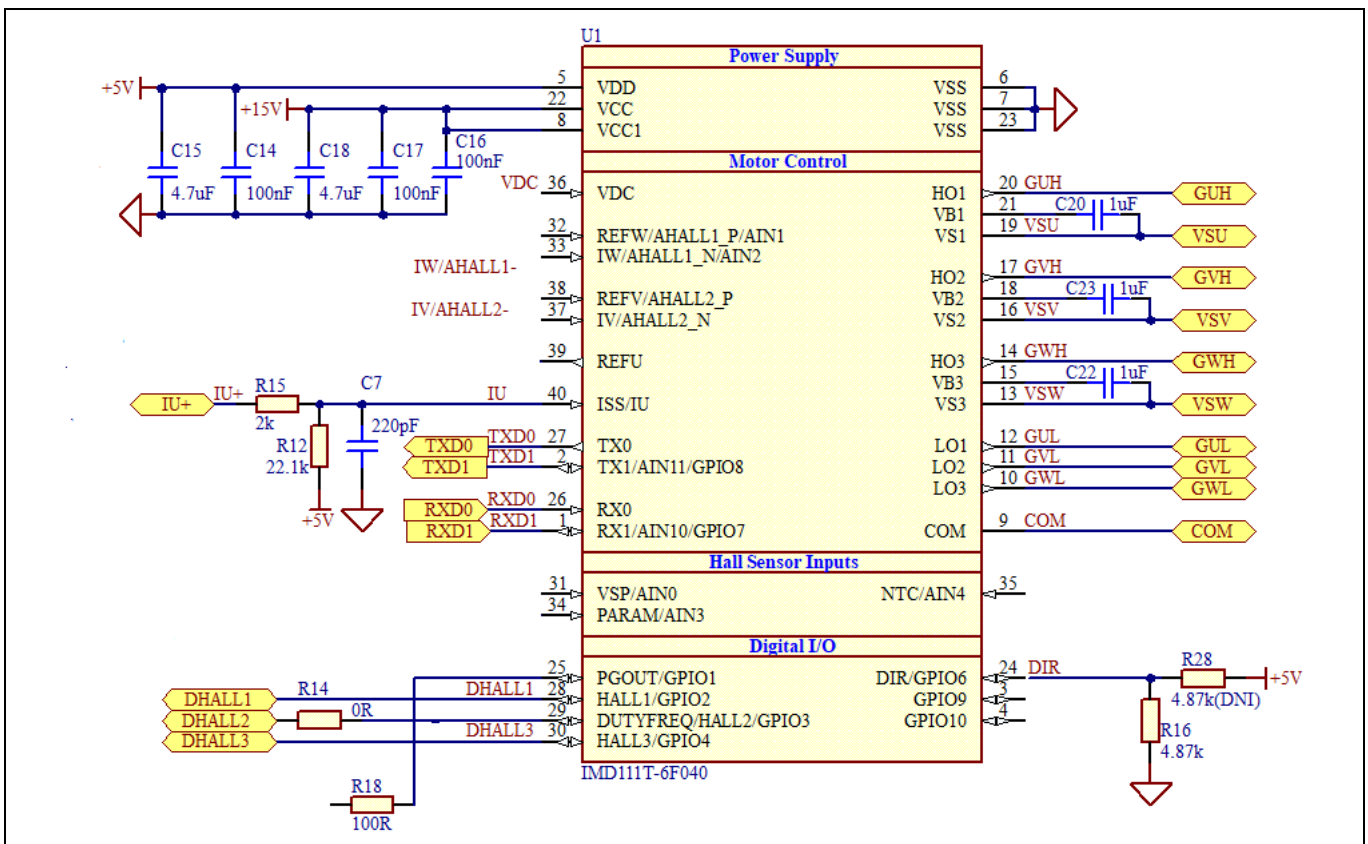

Figure 11 IMD111T schematics

3.2 Layout

The EVAL-M7-D111T board consists of two copper PCB layers. The copper thickness is 35 μm and the board size is 70 mm x 51 mm. The board material is FR4 grade with 1.6 mm thickness. Check Infineon’s website or contact Infineon’s technical support team for more detailed information. The Gerber files are available on the download section of the Infineon homepage. A log-in is required to download this material.

The top layer and bottom layer PCB layout are shown in Figure 12 and Figure 13. For the PCB layout, users should place the decoupling capacitors as close as possible to the input pins, especially for current-feedback sensing and bus-voltage sensing input decoupling capacitors.

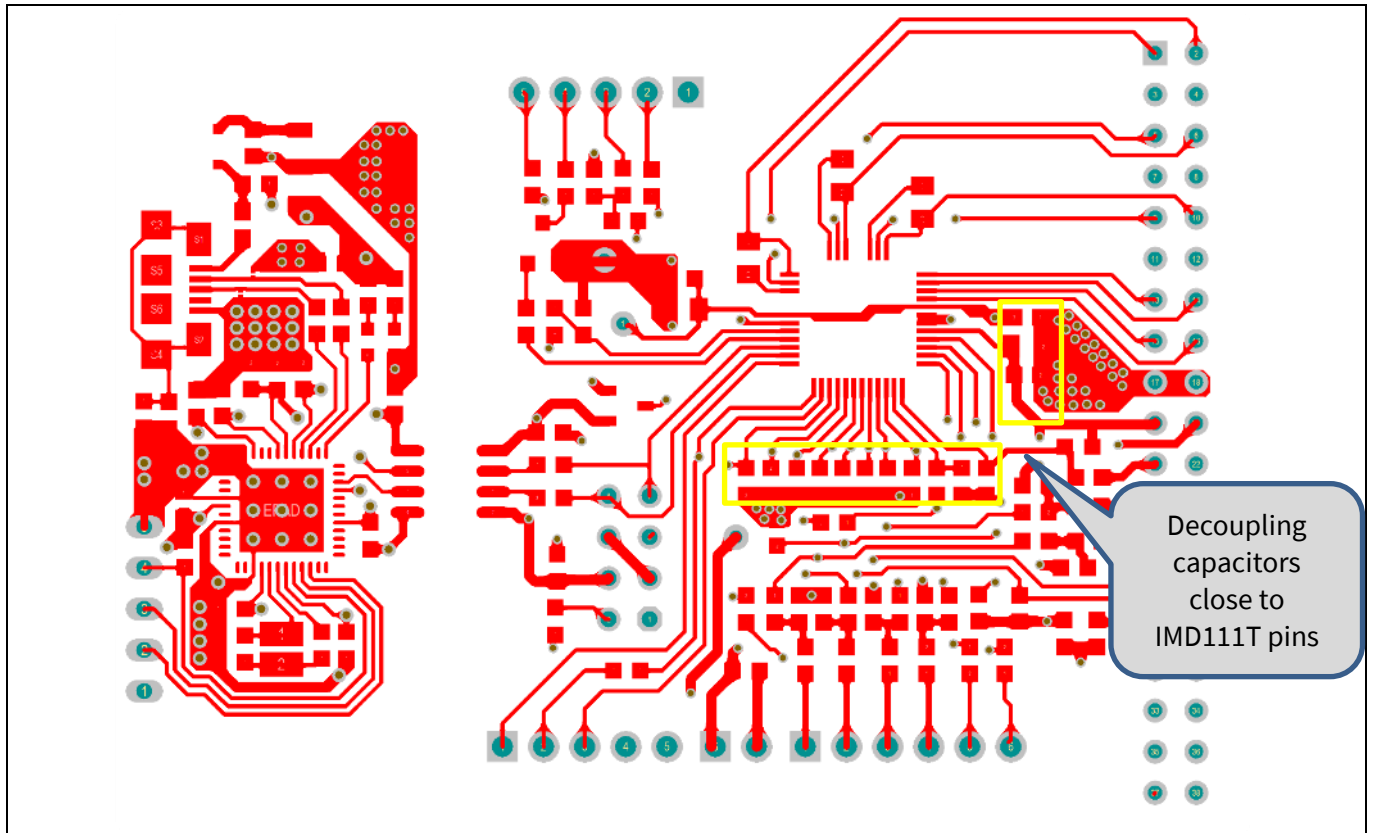

Figure 12 Top layer

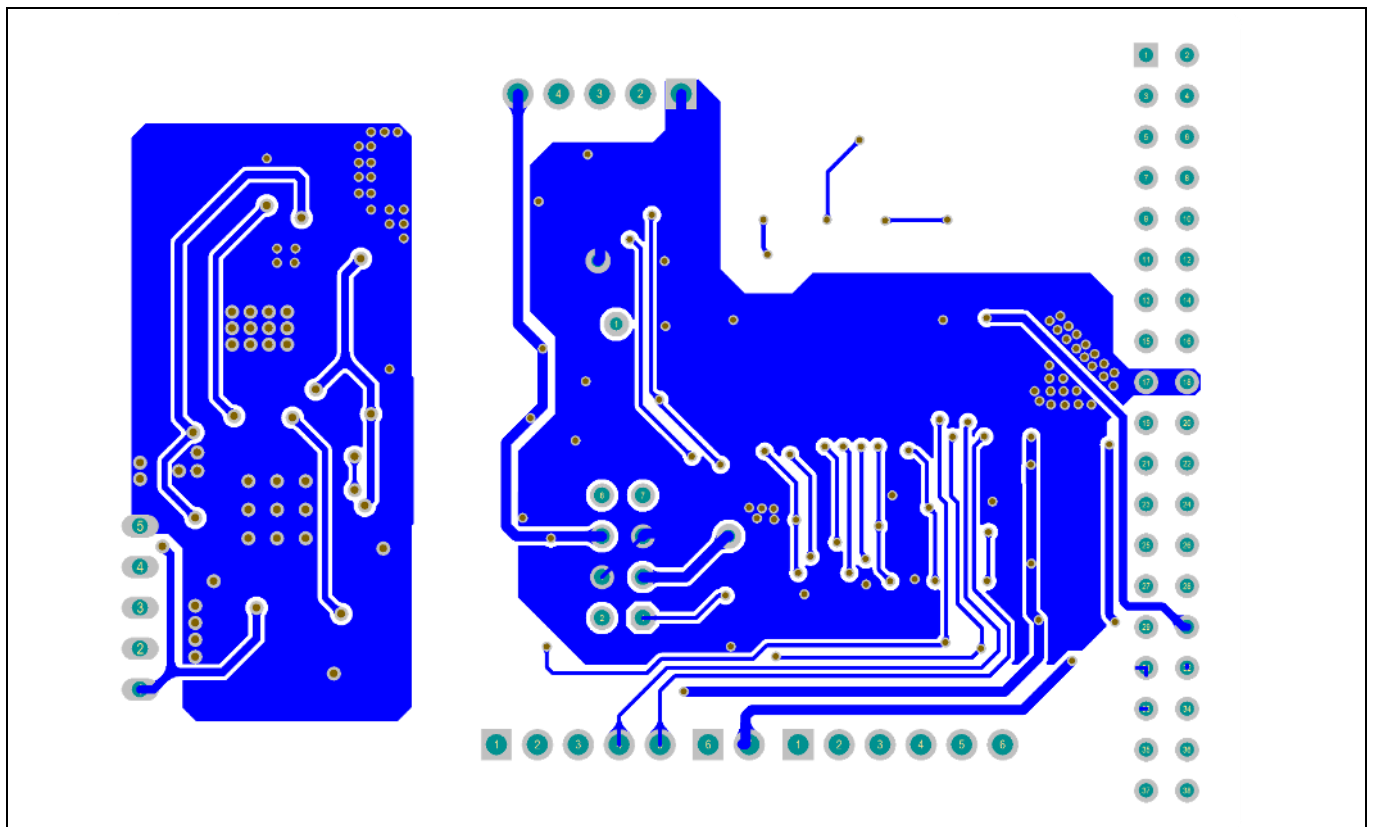

Figure 13 Bottom layer

System design

3.3 Bill of material

The complete bill of material is available in the download section of the Infineon homepage. A log-in is required to download the material. Some key components are shown in Table 10.

Table 10 BOM of the most important parts of the evaluation board EVAL-M7-D111T

S. No.	Ref Designator	Description	Manufacturer	Manufacturer P/N
1	Q1	HEXFET Power MOSFET VDS 30V	Infineon Technologies	IRLML2030TRPbF
2	U1	Motor controller	Infineon Technologies	IMD111T-6F040
3	U101	80 MHz XMC4200 MCU	Infineon Technologies	IFX_XMC4200-Q48F256 BA
4	U102	IC REG LIN 3.3 V 400 mA SOT223-4	Infineon Technologies	IFX25001ME V33
5	V101, V102	Bi-directional TVS Protection Device, 8V, 7pF	Infineon Technologies	ESD237-B1-W0201
6	V103	Medium Power AF Schottky Diode	Infineon Technologies	BAS3010A-03W
7	J1, J3	Terminal Block 5 Pin	Würth Elektronik	691210910005
8	J4	Terminal Block 4 Pin	Würth Elektronik	691210910004
9	LED101	WL-SMCW SMT Mono-color Chip LED Waterclear, Green, 515nm	Würth Elektronik	150060GS75000
10	LED102	WL-SMCW SMT Mono-color Chip LED Waterclear, Blue, 465nm	Würth Elektronik	150060BS75000

System performance

4 System performance

4.1 Test results

This IMD111T control board EVAL-M7-D111T was tested with EVAL-M7- HVIGBT-INV board. Because the EVAL-M7- HVIGBT-INV board is up to 200 W without any external heatsink, the control board was tested up to 200 W due to the limitation. Of course, the EVAL-M7-D111T can drive higher power output when matching with larger power rating boards. Phase current waveforms are shown in Figure 14. Figure 15 shows the inverter-current feedback noise in static condition (less than 10 counts). The static condition means to measure the current feedback when the motor is stopped. A better PCB layout can get lower current feedback noise and improve motor control performance.

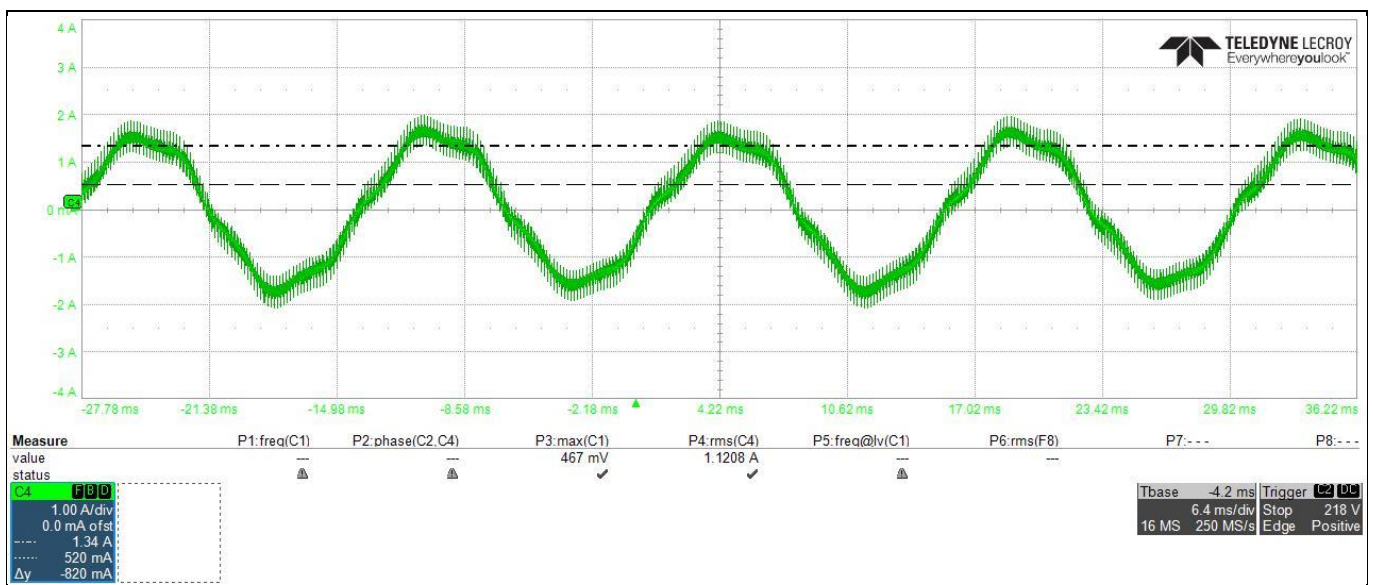

Figure 14 Phase current waveform @ 200 W load



Figure 15 iu & iv @ motor stop, noise <10 cnts

5 Ordering details and other information

The board is now available for customers in small order quantities. Design data are available in the download section of the Infineon homepage. A log-in is required to download the material.

In order to initiate the testing, customers are advised to order this board from the link below:

Buy online: [link](#), or <https://www.infineon.com/madk>

6 References and appendices

6.1 References

- [1] Infineon Technologies AG. Datasheet (2020): iMOTION™ IMD111T/IMD112T - Smart driver for motor control. V1.0 www.infineon.com
- [2] Infineon Technologies AG. User guide (2020): MCEWizard V2.3 user guide. V2.3 www.infineon.com
- Infineon Technologies AG. AppNote (2020): MCEDesigner application guide. V2.3 www.infineon.com

Revision history

Document version	Date of release	Description of changes
V1.0	2021-03-26	First release

Trademarks

All referenced product or service names and trademarks are the property of their respective owners.

Edition 2021-04-15

Published by

Infineon Technologies AG

81726 Munich, Germany

© 2021 Infineon Technologies AG.

All Rights Reserved.

Do you have a question about this document?

Email: erratum@infineon.com

Document reference

UG-2021-17

For further information on the product, technology, delivery terms and conditions and prices please contact your nearest Infineon Technologies office (www.infineon.com).

WARNINGS

Due to technical requirements products may contain dangerous substances. For information on the types in question please contact your nearest Infineon Technologies office.

Except as otherwise explicitly approved by Infineon Technologies in a written document signed by authorized representatives of Infineon Technologies, Infineon Technologies' products may not be used in any applications where a failure of the product or any consequences of the use thereof can reasonably be expected to result in personal injury.