

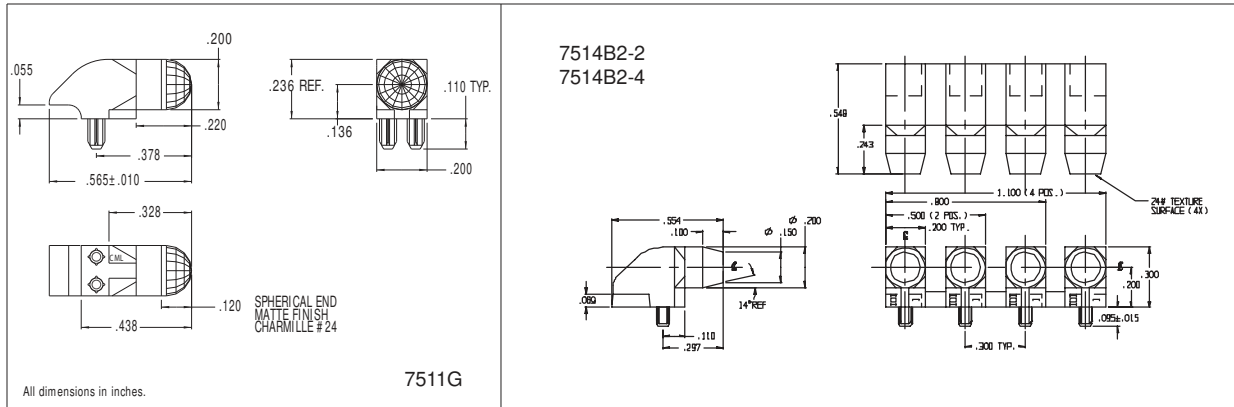

7514B/7511G Series Bright★ Pipes™ Optical Lightpipes
DESCRIPTION AND FEATURES



- Precision engineered with *ray tracing* for bright, optically precise even indication and attractive appearance.
- ESD protection from circuitry for exceptional reliability.
- High contrast and wide viewing angle for greater visibility.
- Available in a variety of colors for added contrast and aesthetics.
- Parts inserted after reflow to permit LED pad inspection before assembly.
- Compliance to UL94V-0
- Low profile for height constrained applications.
- Large lens provides high visibility.
- 7511H2 designed for use with 7012X SMT LED.

MODEL	OUTPUT COLOR
7511G2	DIFFUSED TRANSLUCENT
7511G1	CLEAR RED TINT
7511G5	CLEAR GREEN TINT
7511G7	CLEAR YELLOW

Mounting hole pattern on page 1-X4.