



SG901-1098 Miniature Wi-Fi Radio

Overview

The SG901-1098 WiFi module is a shielded and FCC module certified version of the SG901-1091 Radio Module. It is optimized to simplify successful integration into systems requiring the latest performance with small size. This certified module is a highly integrated single chip based 802.11b/g/n WLAN radio for embedded, low-power and extremely small form factor mobile applications. The product conforms to the IEEE 802.11b, g, and n protocols operating in the 2.45GHz ISM frequency band supporting 802.11g/n modulations from 6 to 65Mbps, and 802.11b modulations.

The SG901-1098 is a fully integrated wireless radio including RF Synthesizer/VCO, high-speed data converters, digital baseband processor, onboard MAC and PHY processors, Power Management, and Power Amplifier.

On-chip auto-calibration eliminates unit specific and customer calibration.

An on-board crystal and filter simplify system integration. The addition of 2.3 to 4.8V and 1.8V supplies, Antenna, and host communication provides a complete WiFi solution.

Host control is provided by either an SDIO or SPI interface at 1.8V.

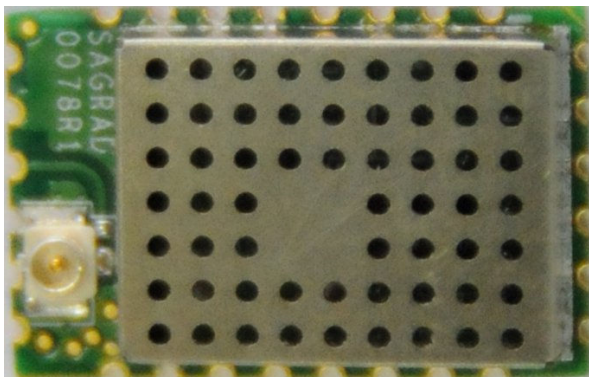

Features

- FCC Module Certified, FCC ID VRA-SG901 1098
- Ultra Low Current Consumption
- Supports SPI Interface and SDIO Interfaces
- Small Footprint (13.5x21.25mm)
- RF connector
- Self Calibrated
- RoHs Compliant
- Fully Integrated 802.11 System Solution
- Fully Compliant with the IEEE 802.11 WLAN Standards
- Support for 802.11g/n Modulations up to 65Mbps, and Mandatory 802.11b Modulations
- Intelligent Power Control, Including 802.11 Power Save Mode
- Factory Support for Linux /Android
- Source Code Available for porting to RTOS or Custom OS
- Available under either:
 - Industrial Temperature -40 to +85C
 - Commercial Temperature 0 to +70C

Applications

- Hand-held Devices
- Embedded Systems
- Portable Systems
- Point of Sale terminals
- Personal Digital Assistants (PDA)
- Cameras
- Cable Replacement

Ordering Information

Packaging	Temp Range	Part Number
Tape and Reel	Industrial	SG901-1098-ET-TR
Bulk	Industrial	SG901-1098-ET-BLK
Tape and Reel	Commercial	SG901-1098-CT-TR
Bulk	Commercial	SG901-1098-CT-BLK

Evaluation Kit Available

This EVK supports embedded software development.

EVK for 1098	SG923-0010
--------------	------------



Block Diagram

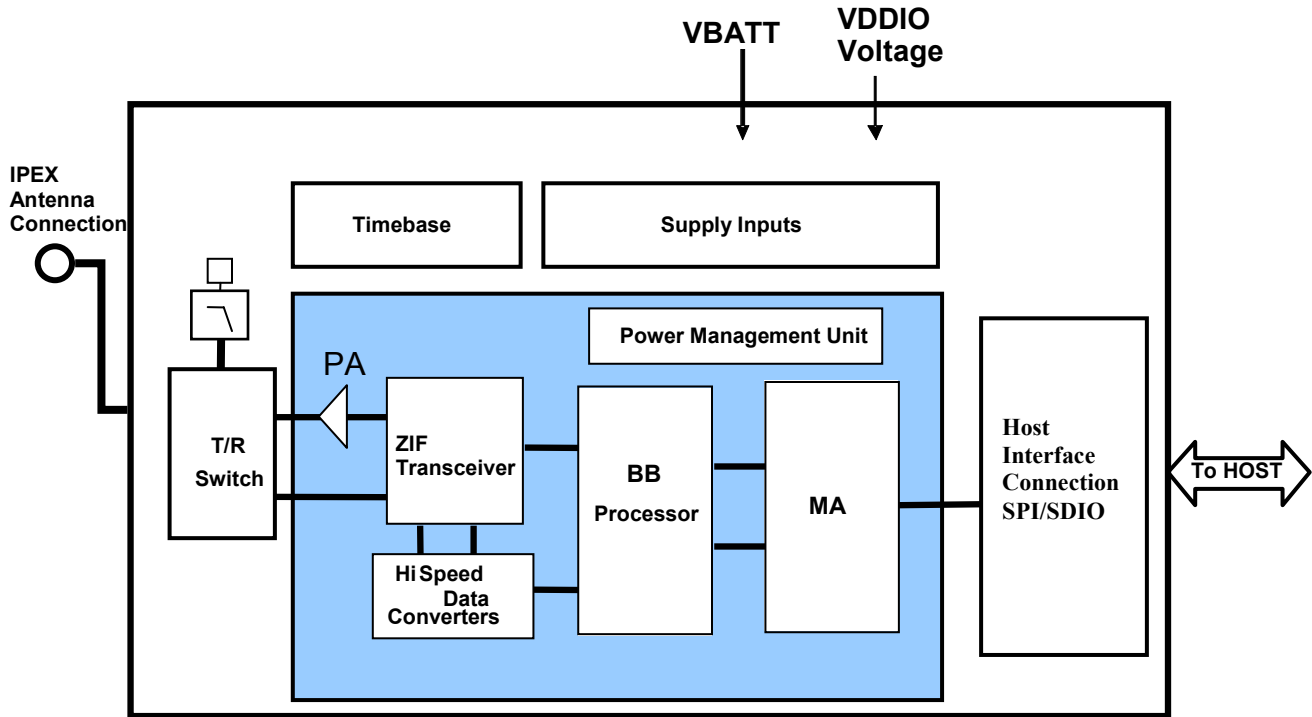

Standards Performance

Target Regulatory Domains	
US – FCC	Yes
Canada – IC	Planned
EU – ETSI	In Progress
Japan – TELEC	Optional
Standards Support	
Modulations	b/g/n Modulations
Power Save	802.11e/WMM/WMM-PS
Encryption	802.11i/WEP/WPA/WPA2
Resources	802.11k
Regulatory Support	802.11d
Fast BSS Transition	802.11r
Protected Frames	802.11w
Direct Connect	Wi-Fi Direct



General Electrical Specifications

Parameter	Test Condition / Comment	Min.	Typ.	Max.	Units	
Absolute Maximum Ratings						
3.3V Supply		2.3	3.3	3.6	V	
VHIO Supply		1.65	1.8	1.95	V	
Operating Conditions and Input Power Specifications						
Operating Temperature Range		-40		85	°C	
3.3V Supply	Input Supply Voltage	2.3	3.3	3.6	V	
	Sleep Mode Current		80		uA	
	Power Save Mode Current	DTIM = 1	0.87		mA	
	Peak TX Current	14.5dBm		294	mA	
	Peak RX Current	Processing OFDM		75	mA	
VHIO Supply	Input Supply Voltage	VHIO input supply determines Host CMOS logic levels	1.65	1.8	1.95	V
	Input Supply Current	RX Active, processing OFDM		0.87	mA	
	Sleep Mode Current			25	uA	
Input Voltage Levels	VIL			0.35VHIO	V	
	VIH		0.625VHIO		V	
Output Voltage Levels	VOL	IOL = 100uA		0.2	V	
	VOH	IOH = -100uA	VHIO-0.2	VHIO	V	

RF Characteristics

Parameter	Test Condition / Comment	Min.	Typ.	Max.	Units
Antenna Port Impedance			50		Ohms
Antenna Input Return Loss	CH1 to CH14		-11		dB
RX Sensitivity	11b, 1Mbps		-96		dBm
	11b, 2 Mbps		-93		dBm
	11b, 5.5 Mbps		-91		dBm
	11b, 11 Mbps		-87		dBm
	11g, 9Mbps		-89.5		dBm
	11g, 18Mbps		-86		dBm
	11g, 36Mbps		-80		dBm
	11g, 54Mbps		-74.5		dBm
	11n, MCS1, 13Mbps		-86.5		dBm
	11n, MCS3, 26Mbps		-81.5		dBm
	11n, MCS5, 52Mbps		-74		dBm
11n, MCS7, 65Mbps		-71		dBm	
Channel to Channel De-sensitivity	CH1 to 14	11g, 54Mbps 10% PER	1		dB
Maximum Input Signal	CH7	11g, 54Mbps	-20		dBm



RF Characteristics cont,

Parameter	Test Condition / Comment		Min.	Typ.	Max.	Units
Adjacent Channel Rejection	11Mbps			38		dBc
	9Mbps			20		dBc
	54Mbps			4		dBc
	MCS1			24		dBc
	MCS7			3		dBc
TX Output Power	11b, 1Mbps	@802.11b spectral mask		18.3		dBm
	11b, 11Mbps			18.3		dBm
	11g, 9Mbps	@802.11g spectral mask		18.3		dBm
	11g, 54Mbps	EVM = -27dB, 4.5%		13.7		dBm
	802.11n MCS1	@802.11n spectral mask		18.3		dBm
	802.11n MCS7	EVM = -27dB		13.5		dBm

Pinout List

SIGNAL NAME	PIN NUMBER	DESCRIPTION		NOTES
RF Pins				
2G4_RF	U.FL Connector		Hirose Electrical PN U.FL-R-SMT(10)	
2G4_RF	11	Optional PAD, Factory enabled only		Careful Layout for this RF Pad and nearby ground
Serial Interface Pins (VHIO Domain, logic levels compatible with the VHIO (Pin 26) input voltage)				
SDCMD	21	SPI MOSI (input)	SDIO CMD	VHIO Domain
SDCLK	22	SPI Clock Input	SDIO CLK	VHIO Domain
SDD0	20	SPI MISO (output)	SDIO Data 0	VHIO Domain
SDD1	19	SPI: Interrupt Output	SDIO Data 1	VHIO Domain, Push Pull. Indicated an interrupt on going rising edge
SDD2	18		SDIO Data 2	VHIO Domain- at reset, low selects SPI, high SDIO
SDD3	17	SPI Chip Select Input	SDIO Data 3	VHIO Domain
Control Pins				
POWERUP	4	Power Up Enable (from Host)		VLDO Domain with internal pull up High = operating, Low = off
RSTn	25	Reset Input		VHIO Domain – Active Low reset, At power up, RSTn must be held LOW until 2 cycles of the CLK32K have been initiated
CLK32K	27	32.768 kHz Sleep Clock Input		VHIO Domain, Required for proper operation
Power and Ground Pins				
VHIO	26	Supply Voltage for I/O's		1.65 to 1.95V, Internally decoupled with a 0.1uF capacitor
3.3V	8	RF PA supply		2.7 to 3.6V, Internally decoupled with a 10uF capacitor
GND	1,2,3,5,6,7,10,12,13,14,15,16,23,24,28,Paddle	Ground Connections		
SPI functions in MODE 3. Clock data in and out at the rising edge. SDCLK is idle at HIGH.				



SG901-1098 SPI/SDIO Interfaces

The SPI/SDIO interface for the SG901-1098 is a 5-wire low voltage interface depicted in figure 1. SDD2 pin High/Active or grounded defines the interface type.

Figure 1: Host Interfacing Block Diagram

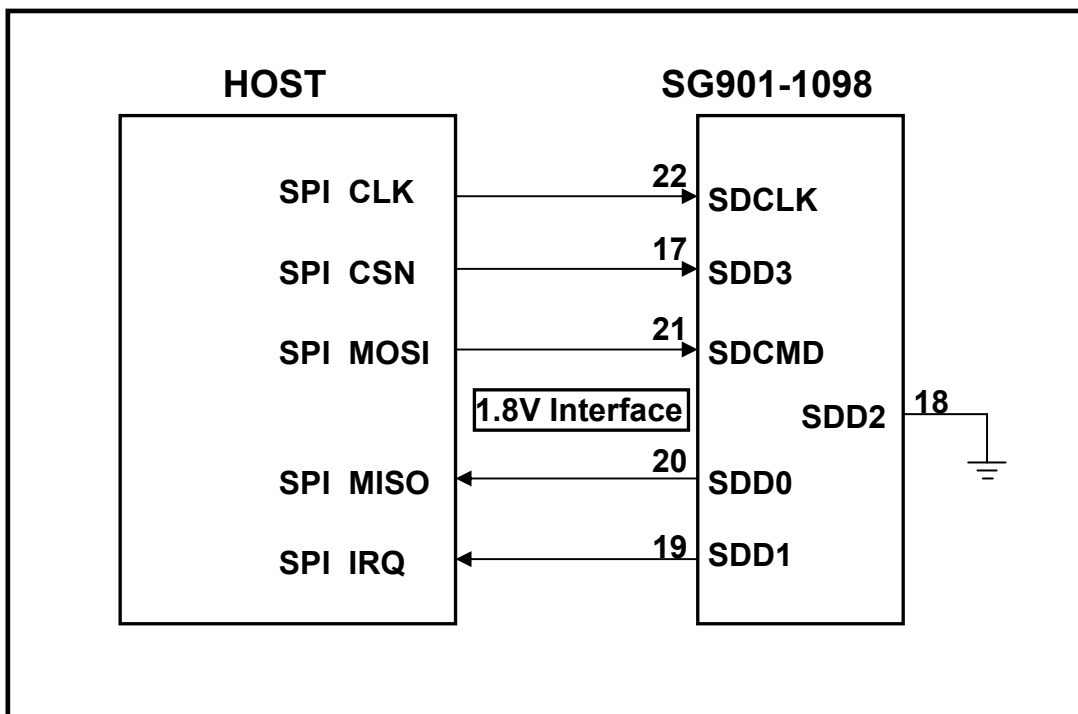

SPI Interface

The five signals of the SG901-1098 SPI interface are as follows:

- SDD3: Device select allows the use of multiple slaves from a Host. (1 device select per slave). This signal is active low. Signal is mandatory, even with only one slave because the Host must drive this signal to indicate SPI frames.
- SDCLK: Clock signal, active for multiple data length cycles during a SPI transfer (SDD3) active). The clock is allowed to be active when SDD3 is not active, in order to serve other possible slaves.
- SDD0: Data transfer from SG1098 to Host. Data is generated on the negative edge of SDCLK by the SG1098 and sampled on the positive edge of SDCLK. When SDD3 is inactive, SDD0 is in Tri-state mode.
- SDCMD: Data transfer from Host to SG1098. Data is generated on the negative edge of SDCLK by the Host and sampled on the positive edge of SDCLK
- SDD1: Interrupt from the SG1098, used to request a SPI transfer to the Host. This signal is active High (Host input must be level sensitive).



The SG901-1098 SPI interface has the following characteristics:

- Maximum operating frequency of 52MHz.
- The SPI interface operates in Half Duplex Mode.
- Host is the Master and the SG1098 is the slave
- The SPI data length, endianness and flow control are configurable. The Host can change the configuration by writing in the SPI configuration register
- 16 and 32 bits word lengths are supported including the following configurable modes, where [bn] is the bit transmission order from left to right:
 - 32-bit Mode0:[b15-b8], [b7-b0], [b31-b24], [b23-b17]
 - 32-bit Mode1:[b31-b24], [b23-b17], [b15-b8], [b7-b0]
 - 32-bit Mode2:[b7-b0], [b15-b8], [b23-b17], [b31-b24]
 - 16-bit Mode0:[b15-b8], [b7-b0]
 - 16-bit Mode1:[b7-b0], [b15-b8]
- The rising clock edge is used for sampling. Active clock edge for shifting is configurable (rise/fall)
- Supports automatic indirect addressing of device internal memory via fixed address SPI register to facilitate bulk DMA transfer
- Support Host wake up of the WLAN block by SPI register access
- The default WLAN configuration is: (refer to figures 2 and 3)
 - 32 bit data length
 - Most significant byte First, default is little Endian
 - Most significant bit First
 - Flow control on SDD0 and in a register

Figure 2: Default SPI transfer from Host to the SG901-1098

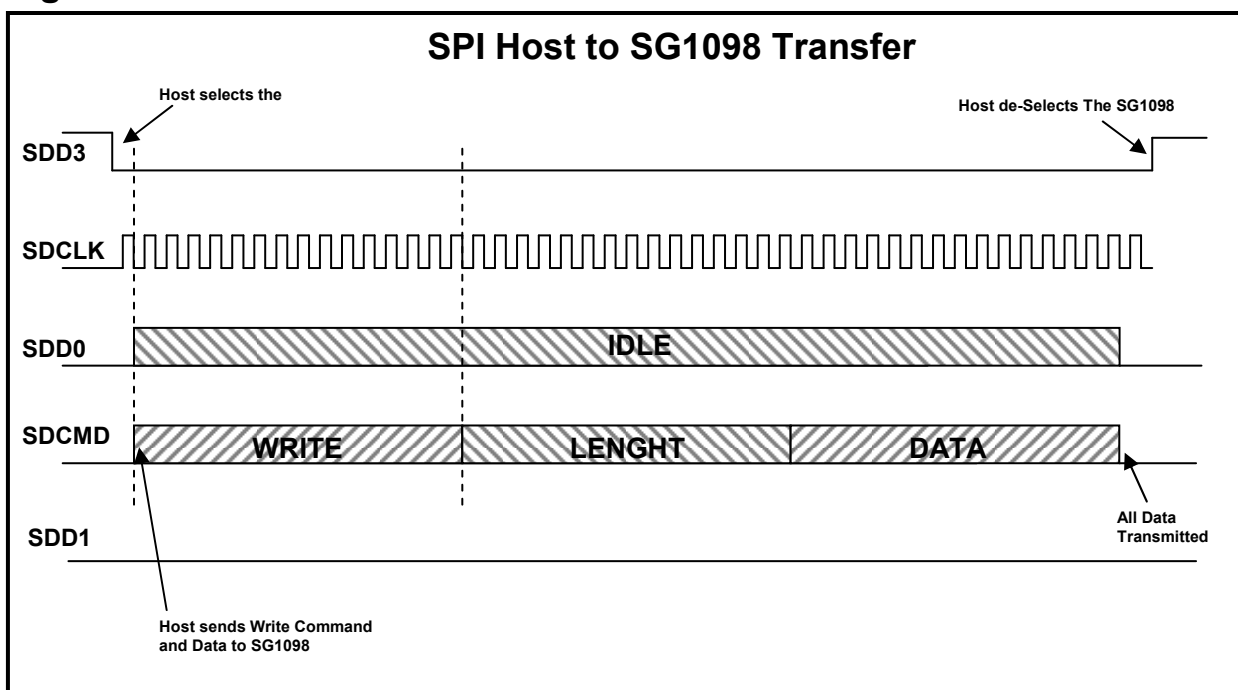
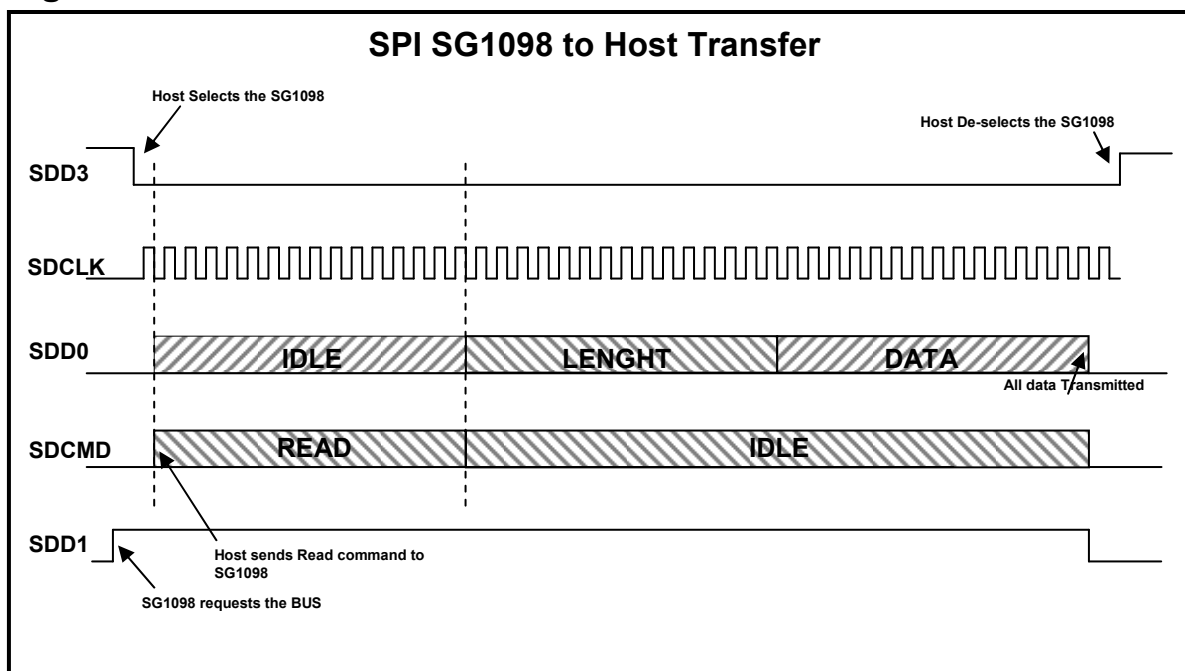



Figure 3: Default SPI data transfer form the SG901-1098 to the Host



SPI Timing Parameters. Refer to figure 4

Symbol	Description	Min.	Typ.	Max.	Units
T1	Clock Period	19.23			ns
T2, T3	Clock High and Low duration	$(0.45 \cdot T1) - T4$		$(.55 \cdot T1) - T4$	ns
T4, T5	Clock rise and fall time (10 TO 90%)	1		2.5	ns
T6	Input Set Up time (SDCMD TO SDCLK active edge)	5		-	ns
T7	Input Hold time (SDCLK active edge to SDCMD Invalid)	5			ns
T8	Output Set Up time (SDCLK active edge to SDD0 Valid)			14.23	ns
T9	Output Hold time (SDCLK active edge to SDD0 Invalid)	5			ns
T10	SDD3 to SDCLK (SDD3 fall to 1 st SDCLK rising edge)	5			ns
T11	SDCLK to SDD3 (Last falling edge of SDCLK to SDD3 rising edge)	1			ns



Figure 4: SPI Timing diagrams

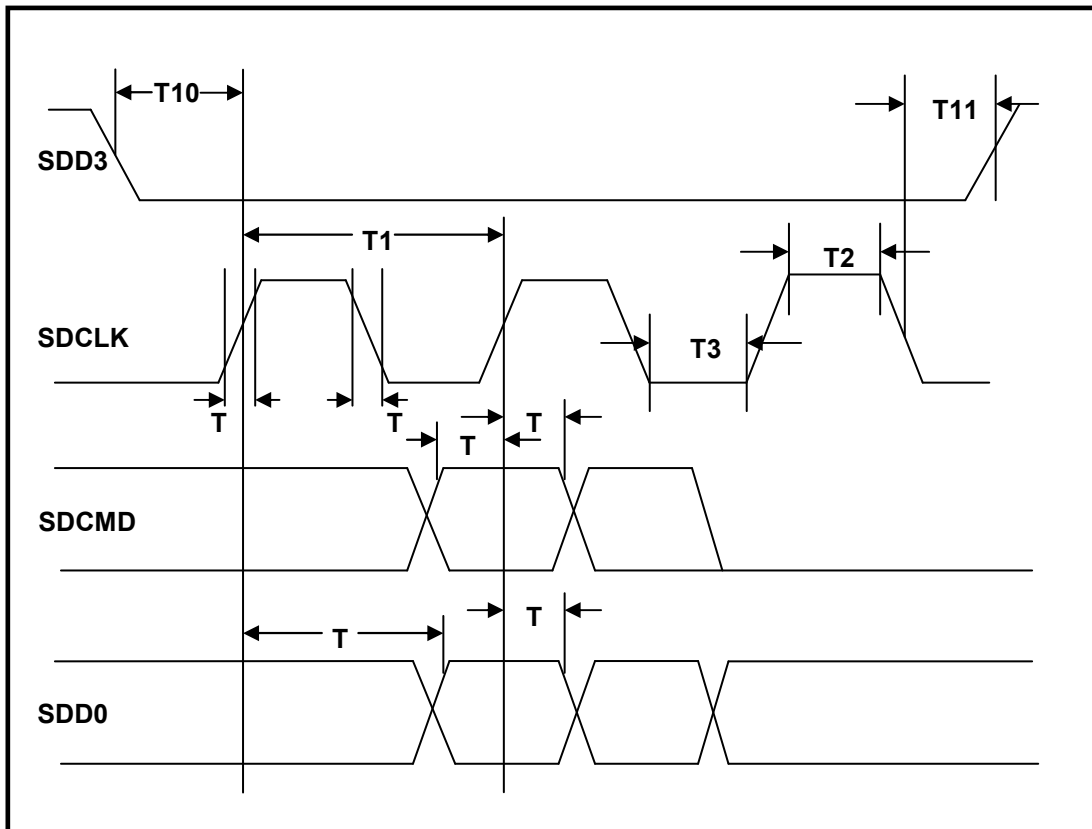

SDIO Interface

The SG901-1098 SDIO interface has the following characteristics:

- Maximum operating frequency of 26MHz.
- The SDIO interface is a 4 to 6 wire data interface
- Compatible with the SDIO specification Version 1.10, except that the voltage range is not SD compatible, but is compatible with the standard I/O levels defined in this data sheet
- Interrupt may be generated to the host in 4 bit SDIO mode even without the SDIO clock.
- The SDIO is master at the Host side and Slave at the 1098 side
- Operation in SD mode from 1 to 4 data bits
- The 6 signals are as follows:

SDCLK: clock signal

SDCMD: Bidirectional SDIO command line

SDD0: Bidirectional data line

SDD1: Bidirectional data line. When no data is present on this line, it is used as an interrupt from the 1098, used to request an SDIO transfer from the 1098 to the host

SDD2: Optional Bidirectional data line

SDD3: Optional Bidirectional data line



Figure 5: SDIO Timing Diagram

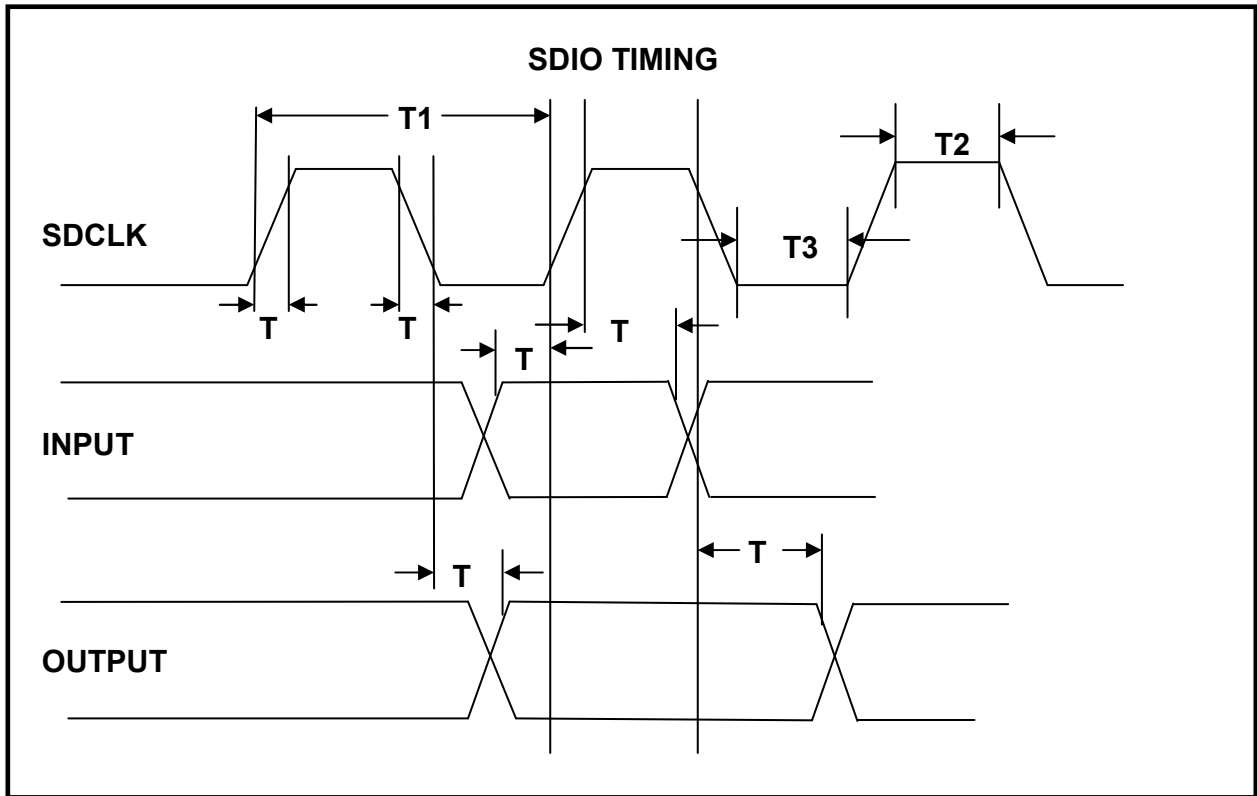

SDIO Interface timing. Refer to figure 5

Symbol	Description	Min.	Typ.	Max.	Units
T1	Clock Period	38.46			ns
T4, T5	Clock Rise and Fall Time (10 to 90%)			9	ns
T2, T3	Clock High and Low Time	10			ns
T6, T7	Input Set Up and Hold Time (SDCMD TO SDCLK active edge)	5		-	ns
T8, T9	Output Delay Time during data transfer mode			14	ns

WLAN Power Up/Down Sequence

The 1098 Power up sequencing is as follows:

- VHIO is applied
- CLK32K (low power clock) is stable
- RSTn pin is released after at least two CLK32K cycles
- POWERUP is asserted. Internal supplies stabilize within 20ms
- The Host must wait 30ms after RSTn release for all internal supplies to stabilize
- The device is then in sleep mode
- The Host shall then wake the module by writing over the Host interface, SPI or SDIO the WUP bit



- The module requests the reference clock already running
- The module will assert the RDY bit and assert the interrupt request to the Host
- The Host can now download the firmware and release the by further SPI/SDIO write
- The Host will wait for the Module to initialize and can clear the WUP bit
- Once initialized including a series of messages between the Host and the module, the Module may not have anything further to do and will enter the sleep state.

The 1098 power down has no constraints. It is recommended that the Host activates the RSTn at least 2 cycles of the CLK32K before powering off the supplies.

Figures 6 depicts the power up and down timing diagrams.

Figure 6. Power On and Off sequence diagrams

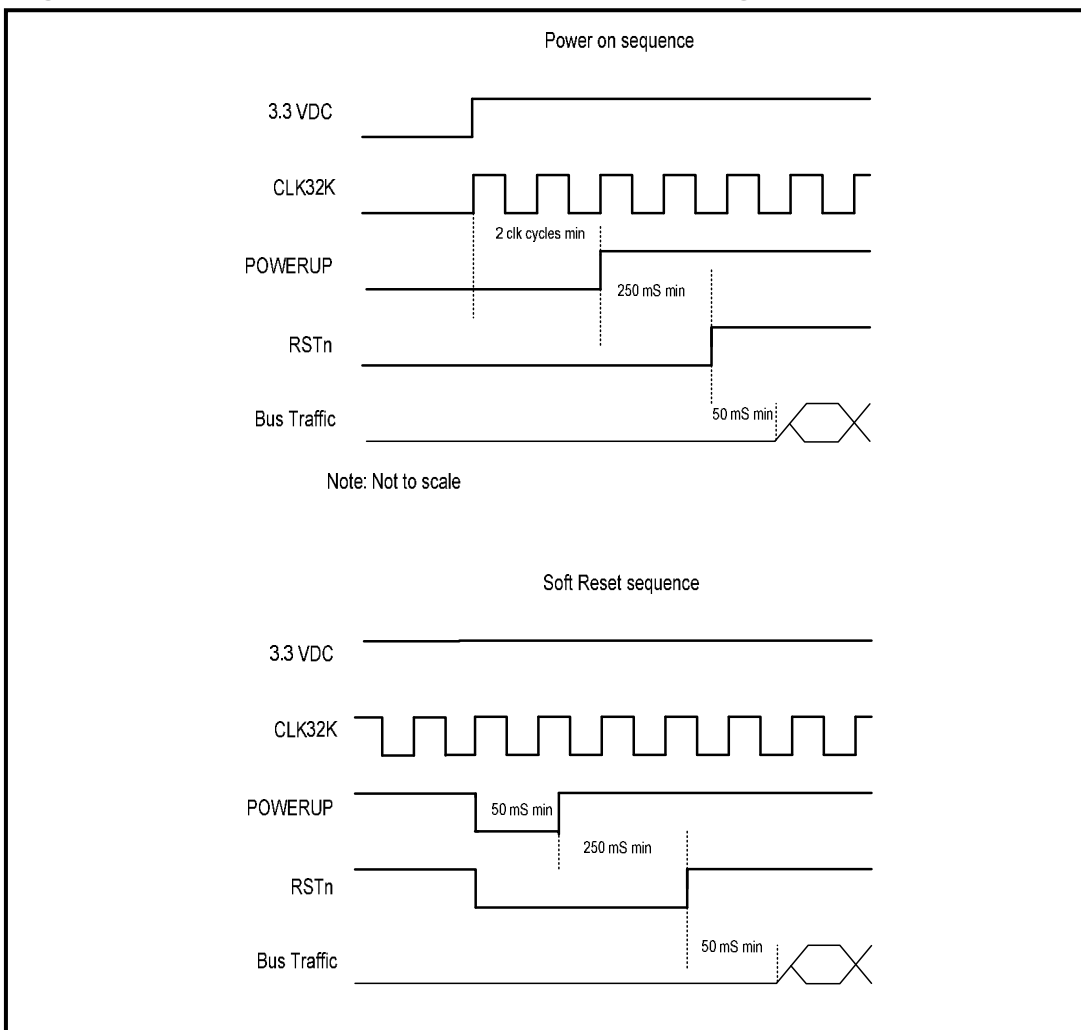



Software Support

The Wi-Fi module is supported via two different software stacks: 1) a Linux device driver (GPL License) that integrates with the Linux mac80211 layer and existing usermode tools, and 2) a phone-handset-oriented chipset-vendor supplied software stack that is available for customers with non-GPL requirements.

In both cases a license is required to distribute the chipset MAC firmware binary.

Linux Stack Features:

- Client mode
- Mini-AP mode (max 5 clients)
- Security: All standard modes (note: all packet encryption handled in MAC hardware)
 - Open System,
 - WEP,
 - WPA (TKIP) PSK and Enterprise, and
 - WPA2 (AES) PSK and Enterprise
- QoS
- OS Support: Linux v2.6 and 3.0, Android
- License: GPL

Vendor Stack Features:

- Client mode
- Mini-AP mode (max 5 clients)
- Security: All standard modes (note: all packet encryption handled in MAC hardware)
 - Open System,
 - WEP,
 - WPA (TKIP) PSK and Enterprise, and
 - WPA2 (AES) PSK and Enterprise
- QoS
- OS Support: Linux v2.6, Android, portable codebase
- License: chipset-vendor SLA

The complete 802.11 stack requires about 350KB of space for the implementation of the entire specification. Extremely small versions can be created by knowledgeable customers but is a considerable task and requires detailed understanding of 802.11.

As a service to customers, Sagrad offers extended technical support on a fee basis.



Mechanical

- Maximum Peak Reflow Temperature: 240°C
- Recommended Reflow Profile:

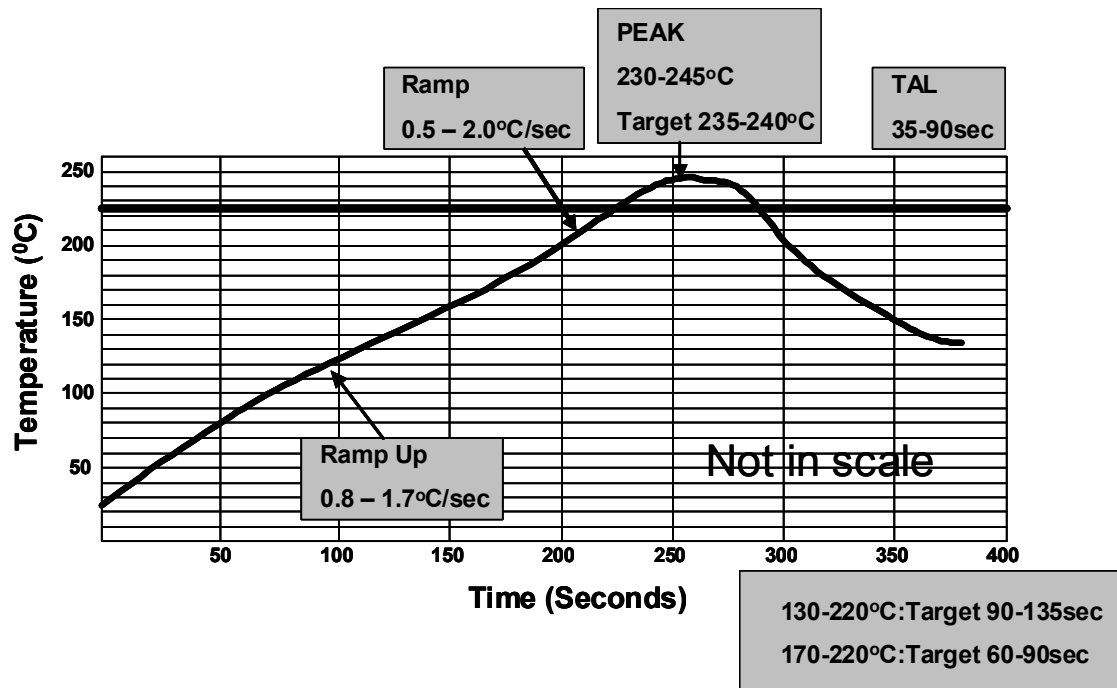

Moisture Level Sensitivity: 1



Mechanical (Bottom view)

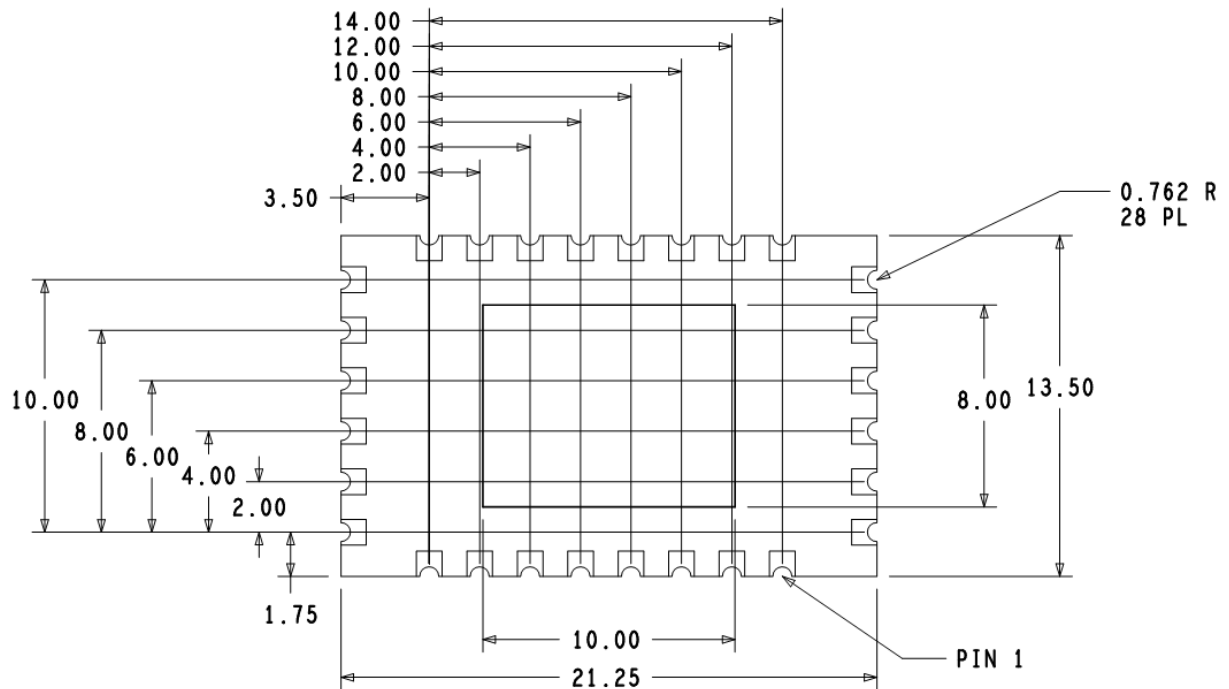

Pin numbering proceeds clockwise in the drawing above.

The nominal size of the part is 13.5x21.25mm with a height of 2.5mm.



Recommended Layout

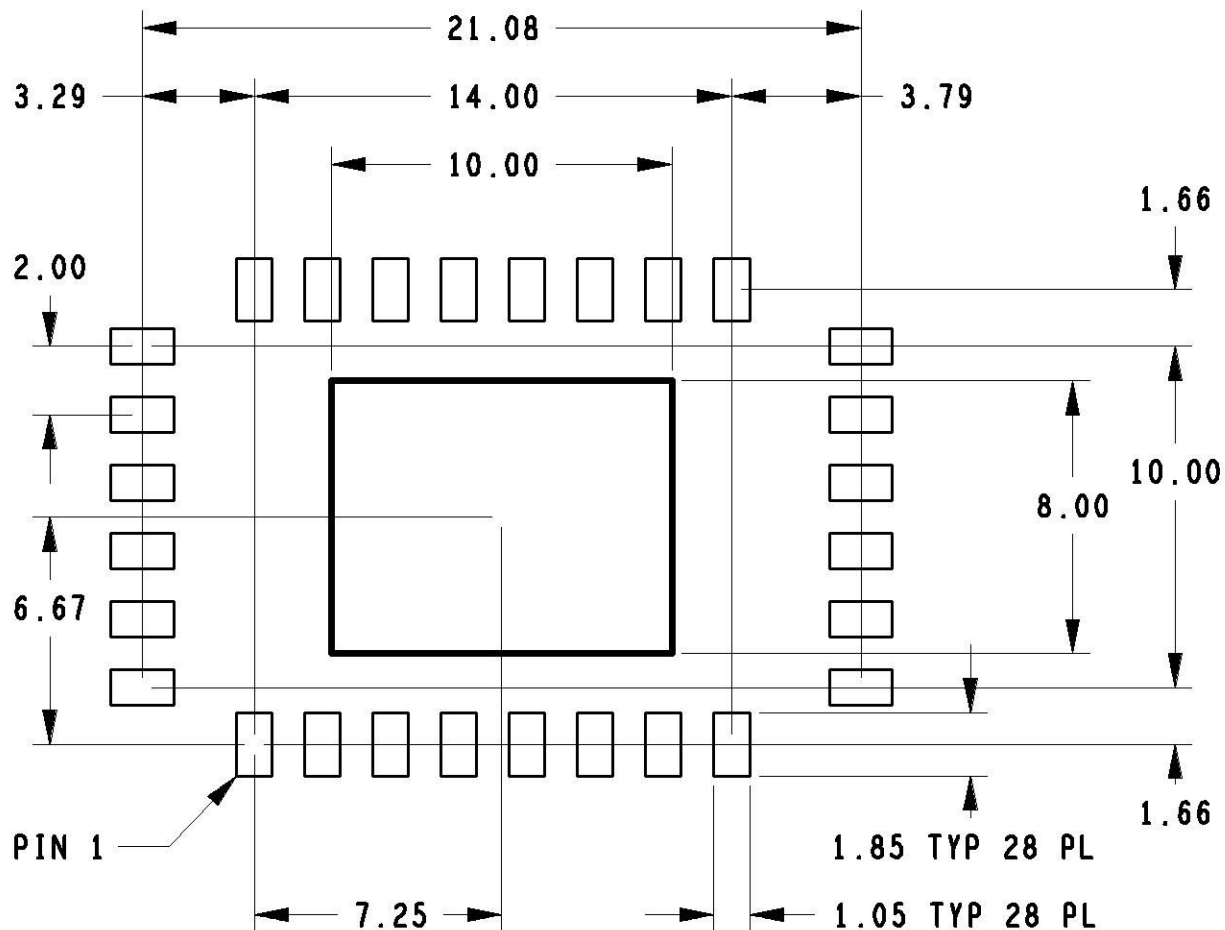

PCB design requires detailed review of center exposed pad. This pad requires good thermal conductivity. Soldering coverage should be maximized and checked via x-ray for proper design. There is a trade off in providing enough soldering for conductivity and too much which allows the module to "float" on the paddle creating reliability issues. Sagrad recommends two approaches, a large center via that allows excess soldering to flow down into the host PCB with smaller vias around it. Or many smaller vias with just enough space for the viscosity of the chosen solder/flux to allow some solder to flow into the smaller vias. Each of these approaches need to result in 60% or more full contact solder coverage on the paddle after reflow. Sagrad strongly encourages PCB layout teams to work with their EMS providers to ensure vias and solder paste designs will result in satisfactory performance.

Note: Pin 1 is on the bottom left of this diagram.

This view is viewed from the top.

Packaging

The part comes packaged in Tape and Reel or Bulk.