

- ALL PARTS ASSEMBLED BY TYCO ELECTRONICS CORP.
- STANDOFFS: POSN 12 (9) STANDOFFS AS SHOWN.
 POSN 16 (12) STANDOFFS, 3 PER DIAGONAL ROW.
 POSN 20 (15) STANDOFFS, 3 PER DIAGONAL ROW.
 POSN 24 (18) STANDOFFS, 3 PER DIAGONAL ROW.
 POSN 28 (21) STANDOFFS, 3 PER DIAGONAL ROW.
 POSN 32 (24) STANDOFFS, 3 PER DIAGONAL ROW.
 POSN 36 (27) STANDOFFS, 3 PER DIAGONAL ROW.
 POSN 40 (30) STANDOFFS, 3 PER DIAGONAL ROW.
 POSN 44 (33) STANDOFFS, 3 PER DIAGONAL ROW.
 POSN 48 (36) STANDOFFS, 3 PER DIAGONAL ROW.
 POSN 52 (39) STANDOFFS, 3 PER DIAGONAL ROW.
 POSN 56 (42) STANDOFFS, 3 PER DIAGONAL ROW.
 POSN 60 (45) STANDOFFS, 3 PER DIAGONAL ROW.

- FLAME RETARDANT, 94 V-0 RATED, GLASS FILLED, NYLON OR POLYESTER, COLOR: BLACK.
- FINISH: BRIGHT TIN-LEAD .000100-.000200 THK OVER NICKEL .000050 MIN THK.
- FINISH: BRIGHT TIN .000100-.000200 THK OVER NICKEL .000050 MIN THK.

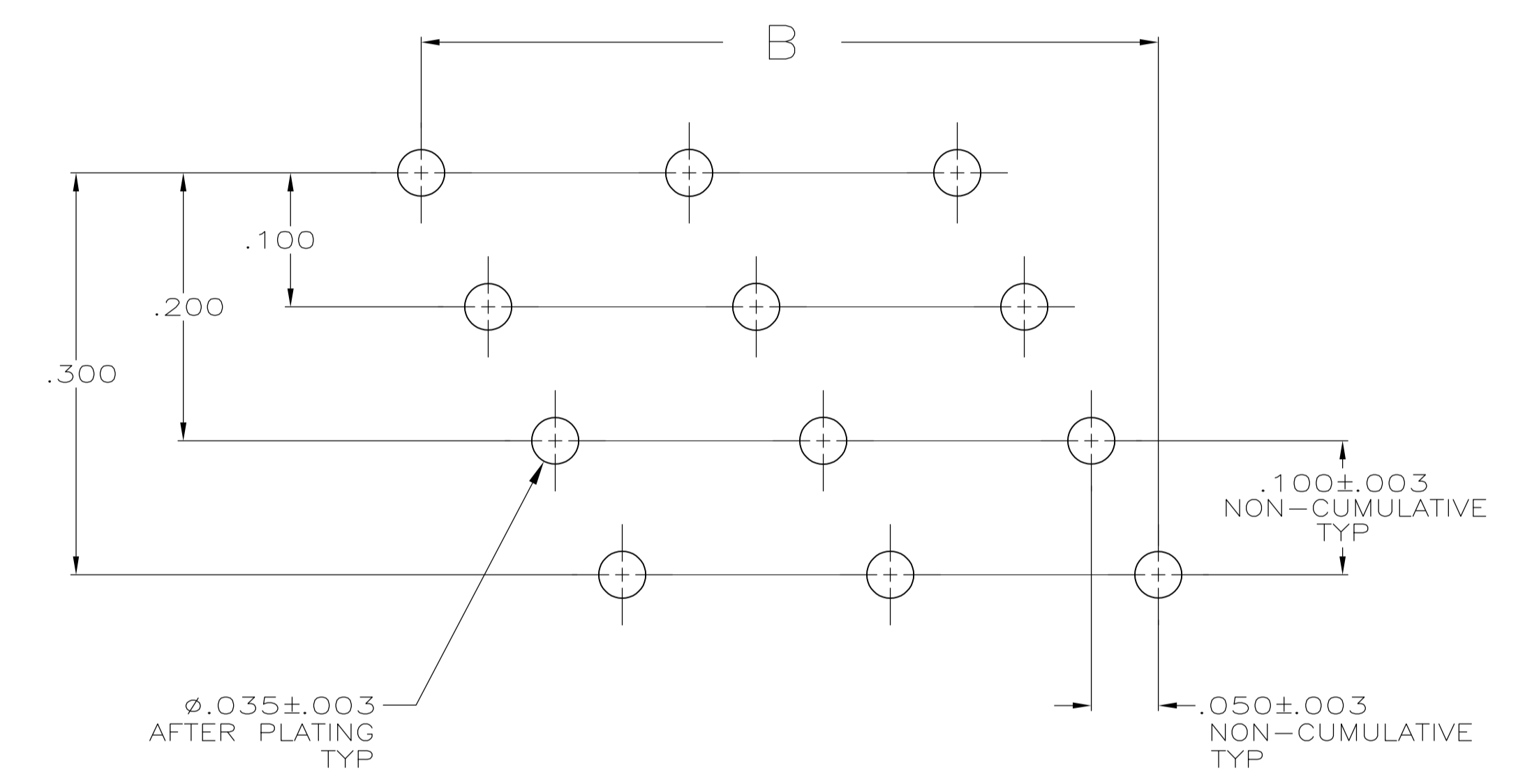

RECOMMENDED HOLE LAYOUT

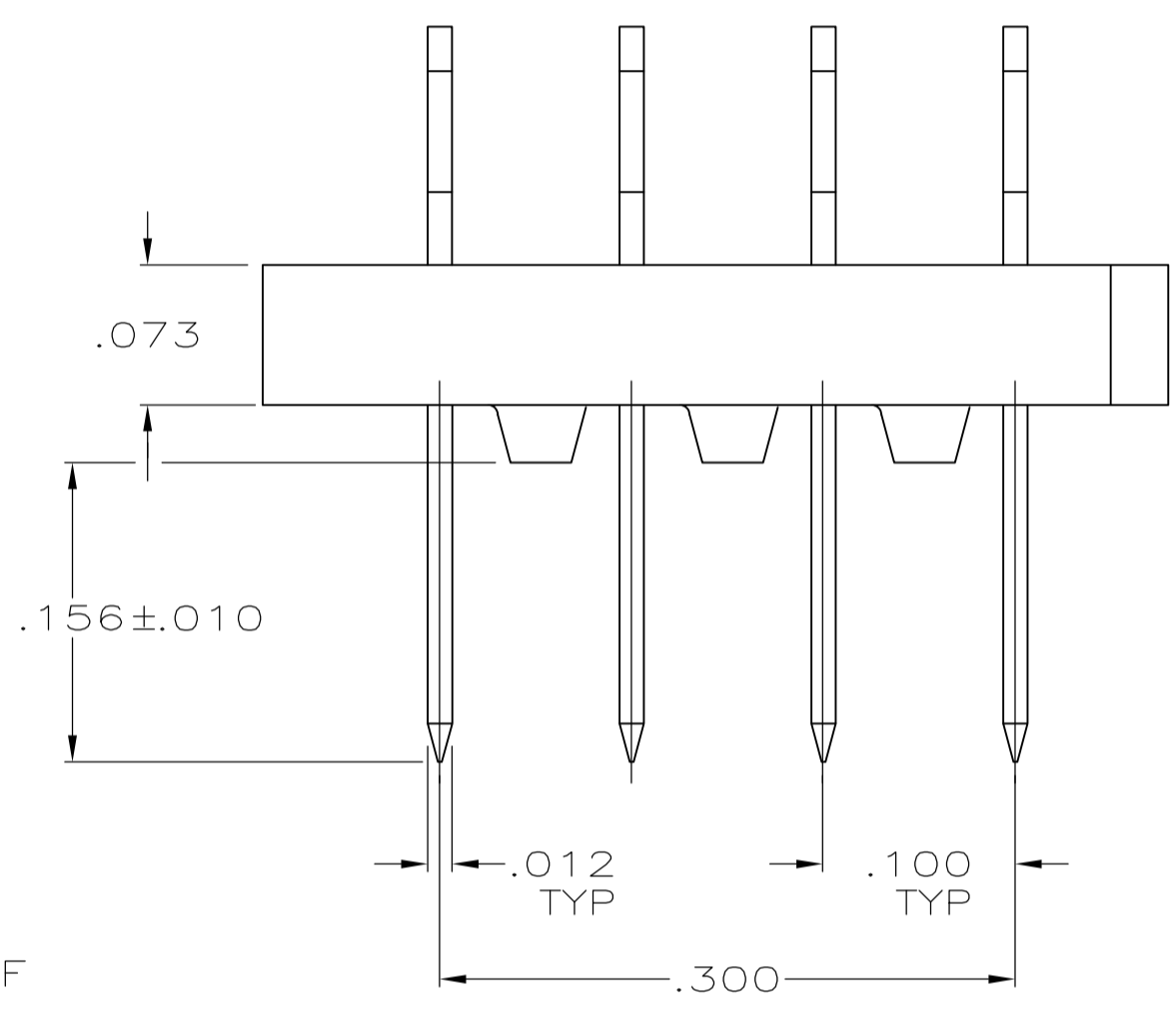
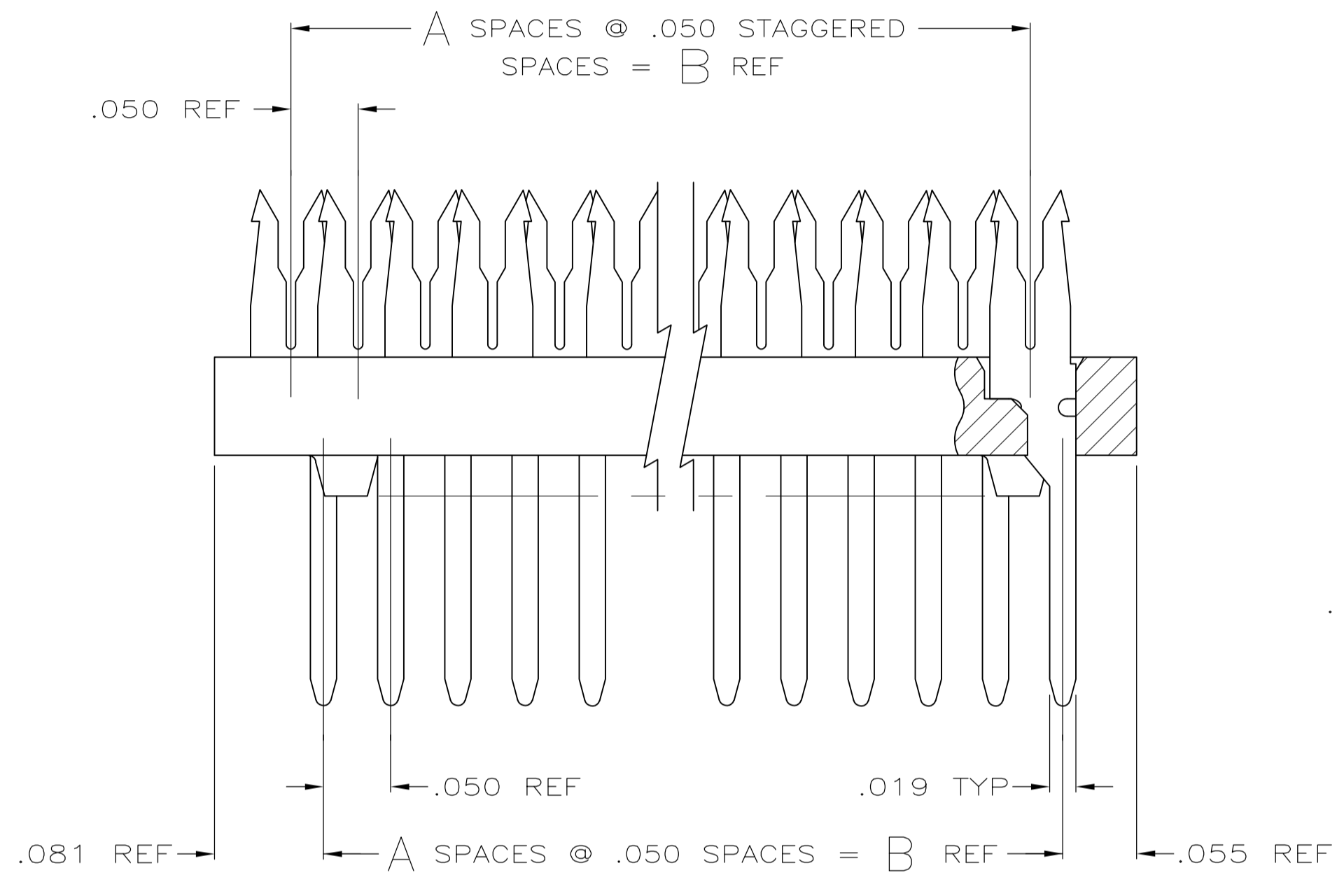
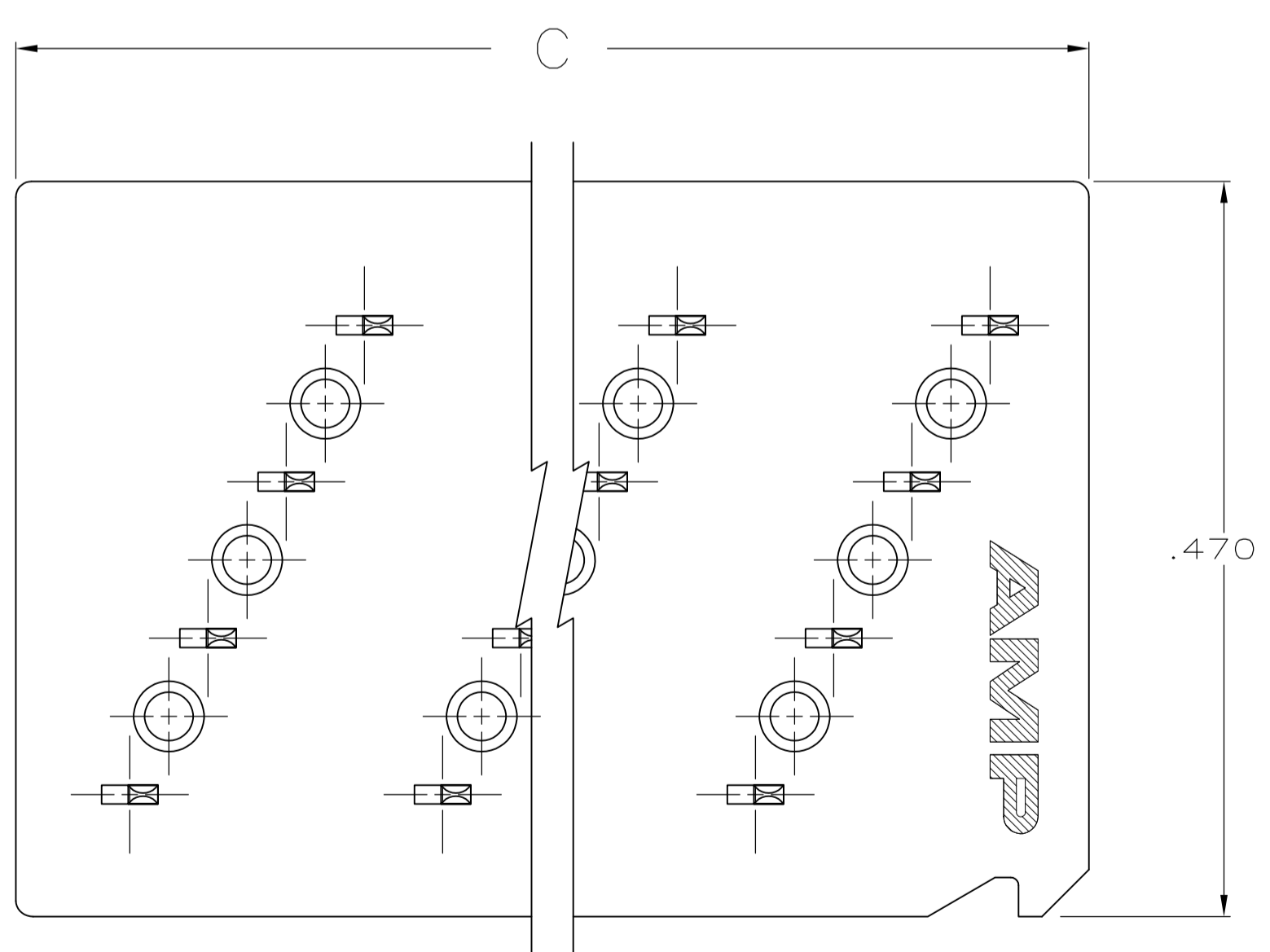

	5	2.086	1.950	39	40	5-111357-8
OBSOLETE	4	3.086	2.950	59	60	1-111357-3
OBSOLETE	4	2.886	2.750	55	56	1-111357-2
OBSOLETE	4	2.686	2.550	51	52	1-111357-1
OBSOLETE	4	2.486	2.350	47	48	1-111357-0
OBSOLETE	4	2.286	2.150	43	44	111357-9
	4	2.086	1.950	39	40	111357-8
OBSOLETE	4	1.886	1.750	35	36	111357-7
OBSOLETE	4	1.686	1.550	31	32	111357-6
OBSOLETE	4	1.486	1.350	27	28	111357-5
OBSOLETE	4	1.286	1.150	23	24	111357-4
OBSOLETE	4	1.086	.950	19	20	111357-3
OBSOLETE	4	.886	.750	15	16	111357-2
OBSOLETE	4	.686	.550	11	12	111357-1
	FINISH	C	B	A	NO OF POSN	PART NUMBER

THIS DRAWING IS A CONTROLLED DOCUMENT.

APPROVED: M. VISELLI, 24-FEB-86

DESIGNED: W. LENKER, 23-FEB-86

DRAWN: S. WELDON, 23-FEB-86

NAME: ASSEMBLY, PADDLEBOARD, FULL ROW .156 LONG POSTS, FULL TIN PLATED CONTACTS AMP-LATCH

SIZE: A1, CAGE CODE: 00779, DRAWING NO: 111357

SCALE: 10:1, SHEET: 1 OF 1, REV: H

STE TE Connectivity