

MAX4987AE

Overvoltage-Protection Controller with USB ESD Protection

General Description

The MAX4987AE are overvoltage protection devices with built-in ESD protection for USB data lines. These devices feature a low 100m Ω (typ) R_{ON} internal nFET switch and protect low-voltage systems against voltage faults up to +28V. When the input voltage exceeds the overvoltage threshold or decreases below the undervoltage threshold, the internal nFET switch is turned off to prevent damage to the protected components.

All switches feature a minimum 1.5A current-limit protection. During a short-circuit occurrence, the switch operates in an autoretry mode where the internal nFET switch is turned on to check if the fault has been removed. The autoretry interval is 30ms, and if the fault is removed, the nFET switch remains on.

The MAX4987AE feature low-capacitance (3pF) ESD protection for USB data lines that allow transmission of high-speed USB 2.0 signals.

The overvoltage threshold (OVLO) is preset to 6.15V. The undervoltage thresholds (UVLO) are preset to 2.55V (MAX4987AE). When the input voltage drops below the undervoltage (UVLO) threshold, the devices enter a low-current standby mode.

All devices are offered in a small 2mm x 3mm, 8-pin TDFN package and operate over the -40°C to +85°C extended temperature range.

Applications

- Cell Phones
- Media Players

Features

- Input Voltage Protection Up to +28V
- Integrated Low R_{ON} (100m Ω) nFET Switch
- Internal Overcurrent Protection 1.5A (min)
- Overcurrent Protection (Autoretry)
- Enable Input
- Internal 30ms Startup Delay
- Low-Capacitance USB High-Speed Data Line ESD Protection (3pF)
 - ± 15 kV Human Body Model
 - ± 15 kV IEC61000-4-2 Air Gap
 - ± 6 kV IEC61000-4-2 Contact
- Thermal-Shutdown Protection
- 2mm x 3mm, 8-Pin TDFN Package

[Ordering Information](#) and [Typical Operating Circuit](#) appears at end of data sheet.

Absolute Maximum Ratings

(All voltages referenced to GND.)

IN 0.3V to +30V
 OUT -0.3V to +(IN + 0.3V)
 V_{CC}, \overline{EN} , \overline{ACOK} , CD+, CD- -0.3V to +6V
 Continuous Power Dissipation (T_A = +70°C) for multilayer board:
 8-Pin TDFN (derate 16.7mW/°C above +70°C) 1333mW

Operating Temperature Range -40°C to +85°C
 Junction Temperature +150°C
 Storage Temperature Range -65°C to +150°C
 Lead Temperature (soldering) +300°C

Stresses beyond those listed under "Absolute Maximum Ratings" may cause permanent damage to the device. These are stress ratings only, and functional operation of the device at these or any other conditions beyond those indicated in the operational sections of the specifications is not implied. Exposure to absolute maximum rating conditions for extended periods may affect device reliability.

Package Information

PACKAGE TYPE: 8 TDFN	
Package Code	T823-1
Outline Number	21-0174
THERMAL RESISTANCE, FOUR-LAYER BOARD	
Junction to Ambient (θ _{JA})	60.0°C/W
Junction to Case (θ _{JC})	10.8°C/W

Package thermal resistances were obtained using the method described in JEDEC specification JESD51-7, using a four-layer board. For detailed information on package thermal considerations, refer to www.maximintegrated.com/thermal-tutorial.

For the latest package outline information and land patterns (footprints), go to www.maximintegrated.com/packages. Note that a "+", "#", or "-" in the package code indicates RoHS status only. Package drawings may show a different suffix character, but the drawing pertains to the package regardless of RoHS status.

Electrical Characteristics

(V_{IN} = +2.2V to +28V, T_A = -40°C to +85°C, unless otherwise noted. Typical values are at V_{IN} = +5V and T_A = +25°C.)

PARAMETER	SYMBOL	CONDITIONS	MIN	TYP	MAX	UNITS	
ANALOG SWITCH							
Input-Voltage Range	V _{IN}		2.2		28	V	
V _{CC} Input Voltage	V _{CC}				5.5	V	
Input Supply Current	I _{IN}	$\overline{EN} = 0V, V_{IN} > V_{UVLO}$		60	150	μA	
		$\overline{EN} = 5V, V_{IN} > V_{UVLO}$		50	100		
UVLO Supply Current	I _{UVLO}	V _{IN} < V _{UVLO}			40	μA	
IN Undervoltage Lockout	V _{UVLO}	(V _{IN} falling)		2.3		V	
		(V _{IN} rising)	MAX4987AE	2.35	2.55		2.75
IN Undervoltage Lockout Hysteresis				1		%	
Overvoltage Trip Level	V _{OVLO}	(V _{IN} rising)		5.55	6.15	6.45	V
		(V _{IN} falling)		5.5			
IN Overvoltage Lockout Hysteresis				1		%	
Switch On-Resistance	R _{ON}	V _{IN} = 5V, I _{OUT} = 500mA		100	200	mΩ	
Overcurrent Protection Threshold	I _{LIM}		1.5		4.2	A	
Maximum Output Capacitance		V _{IN} = 5V, no overcurrent shutdown		1000		μF	
CD+ and CD- Leakage Current	I _{LKG CD}	V _{CC} = 5.5V, V _{CD} = 0V, 3.3V	-300		+300	nA	
CD+ and CD- Capacitance	C _{CD}	f = 1MHz, V _{CD} = 0.5p-p		3		pF	

Electrical Characteristics (continued)

($V_{IN} = +2.2V$ to $+28V$, $T_A = -40^{\circ}C$ to $+85^{\circ}C$, unless otherwise noted. Typical values are at $V_{IN} = +5V$ and $T_A = +25^{\circ}C$.)

PARAMETER	SYMBOL	CONDITIONS	MIN	TYP	MAX	UNITS
DIGITAL SIGNALS						
ACOK Output Low Voltage	V_{OL}	$I_{SINK} = 1mA$			0.4	V
ACOK High-Leakage Current		$V_{ACOK} = 5.5V$, flag deasserted			1	μA
EN Input-Voltage High	V_{IH}		1.4			V
EN Input-Voltage Low	V_{IL}				0.4	V
EN Input-Leakage Current	I_{LEAK}	$V_{EN} = 5.5V$	-1		+1	μA
TIMING CHARACTERISTICS (Note 1)						
Debounce Time	t_{INDBC}	Time from $V_{UVLO} < V_{IN} < V_{OVLO}$ to charge-pump enable		30		ms
ACOK Assertion Time	t_{ACOK}	$V_{UVLO} < V_{IN} < V_{OVLO}$, to ACOK low		30		ms
Switch Turn-On Time	t_{ON}	$V_{UVLO} < V_{IN} < V_{OVLO}$, $R_{LOAD} = 100\Omega$, from 10% to 90% of V_{OUT}		3		ms
Switch Turn-Off Time	t_{OFF}	$V_{IN} < V_{UVLO}$ or $V_{IN} > V_{OVLO}$ to internal switch off, $R_{LOAD} = 100\Omega$			10	μs
Current-Limit Turn-Off Time	t_{BLANK}	Overcurrent fault to internal switch off		10		μs
Autoretry Time	t_{RETRY}	From overcurrent fault to internal switch turn-on		30		ms
THERMAL PROTECTION						
Thermal Shutdown	T_{SHDN}			150		$^{\circ}C$
Thermal-Shutdown Hysteresis				40		$^{\circ}C$
ESD PROTECTION						
CD+ and CD-		Human Body Model		± 15		kV
		IEC61000-4-2 Air Gap		± 15		
		IEC61000-4-2 Contact		± 6		
All Other Pins		Human Body Model		± 12		kV

Note 1: All timing is specified using 20% and 80% levels, unless otherwise noted.

Typical Operating Characteristics

($T_A = +25^{\circ}C$, unless otherwise noted.)

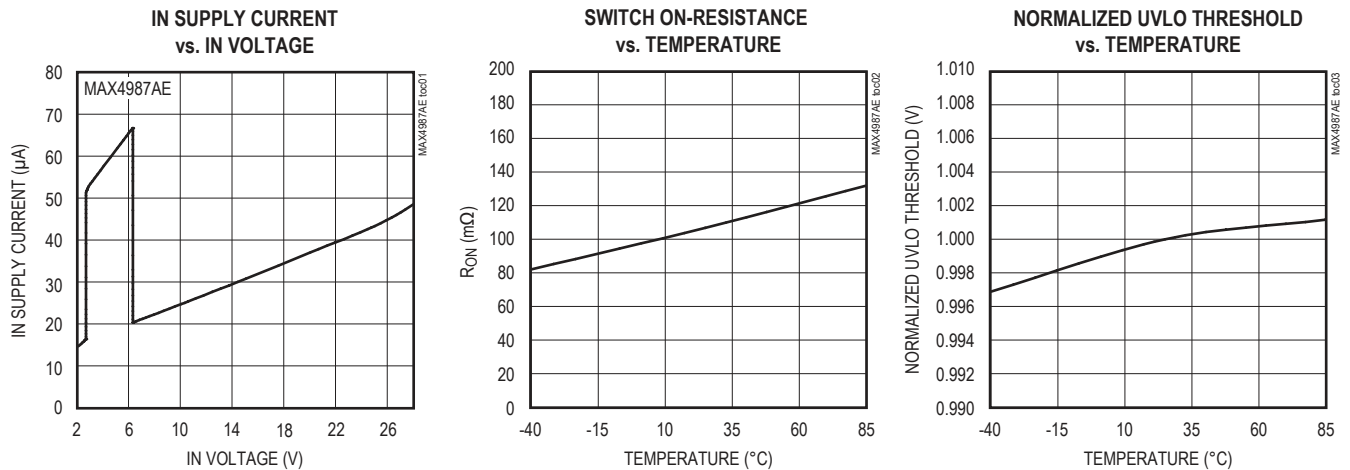

Typical Operating Characteristics (continued)

($T_A = +25^\circ\text{C}$, unless otherwise noted.)

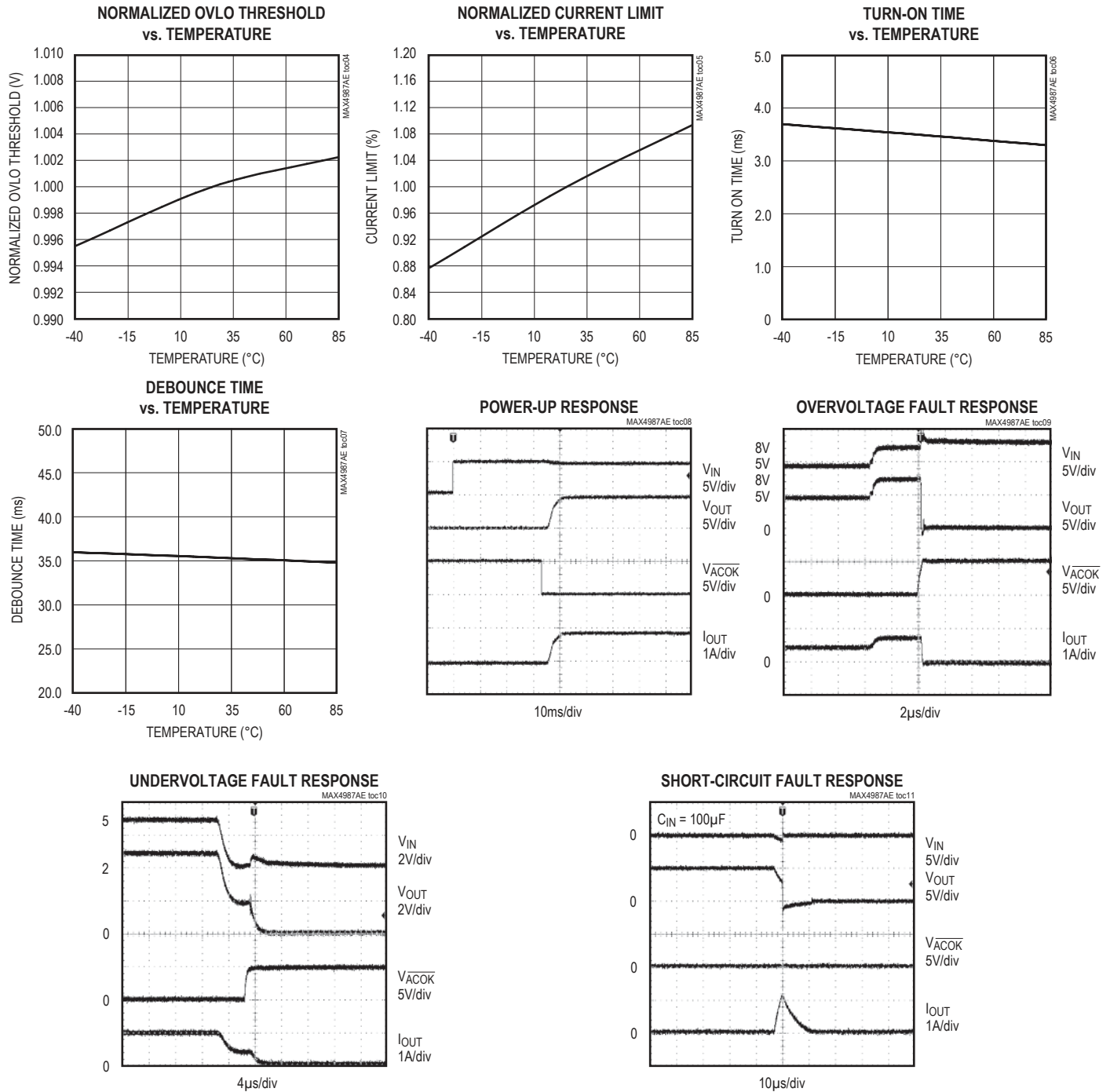

Pin Configuration

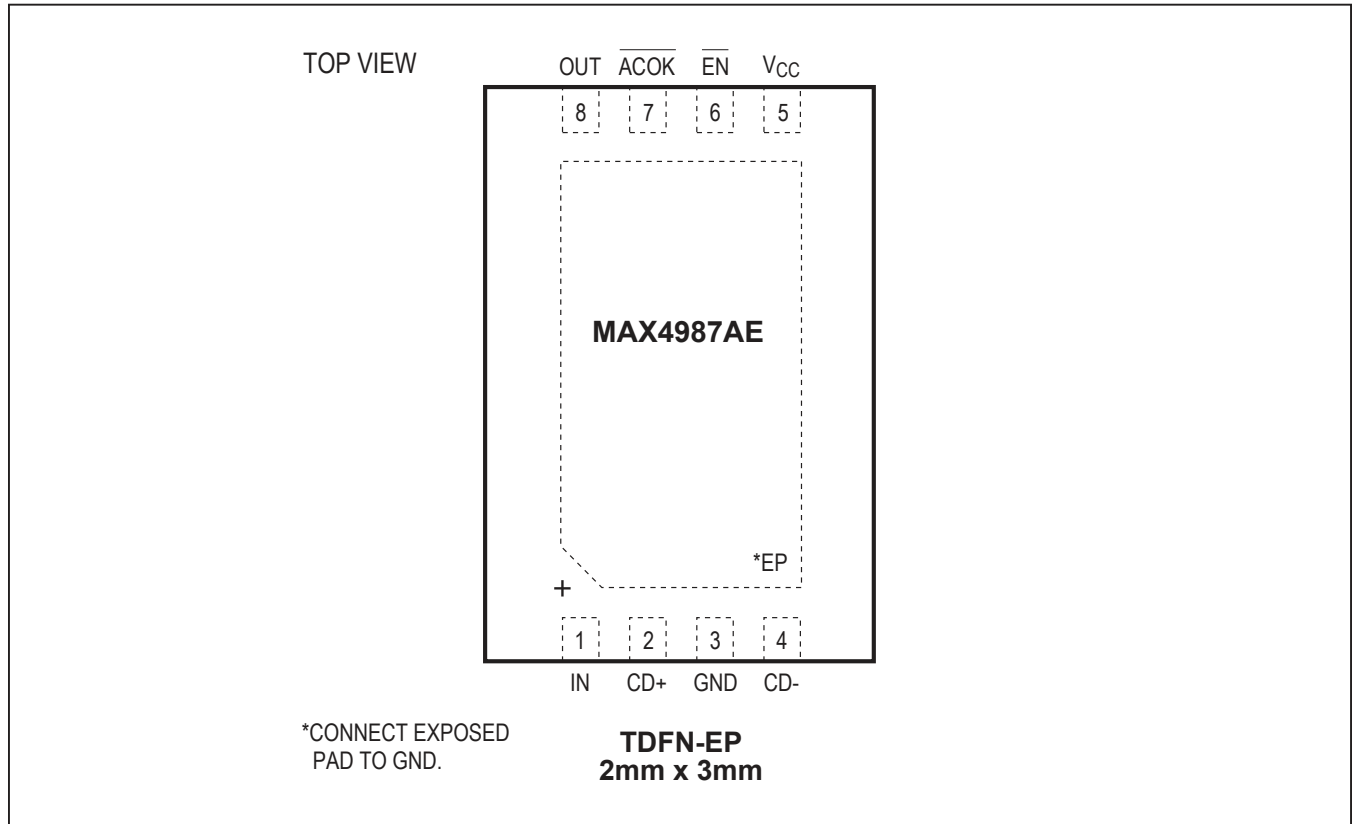

Pin Description

PIN	NAME	FUNCTION
1	IN	Voltage Input. Bypass IN with a 1µF ceramic capacitor as close to the device as possible to obtain ±15kV HBM ESD protection. No capacitor required to obtain ±2kV HBM ESD protection.
2	CD+	USB Data Line
3	GND	Ground
4	CD-	USB Data Line
5	V _{CC}	Positive Supply-Voltage Input. V _{CC} is required only when USB signals are present.
6	$\overline{\text{EN}}$	Enable Active-Low Input. Drive $\overline{\text{EN}}$ low to enable the switch. Drive $\overline{\text{EN}}$ high to disable the switch.
7	$\overline{\text{ACOK}}$	Open-Drain Adapter-Voltage Indicator Output. $\overline{\text{ACOK}}$ is driven low after the V _{IN} voltage is stable between UVLO and OVLO for 30ms (typ). Connect a pullup resistor from ACOK to the logic I/O voltage of the host system.
8	OUT	Output Voltage. Output of internal switch.
EP	EP	Exposed Pad. Connect exposed pad to ground. Do not use EP as a sole ground connection.

Functional Diagram

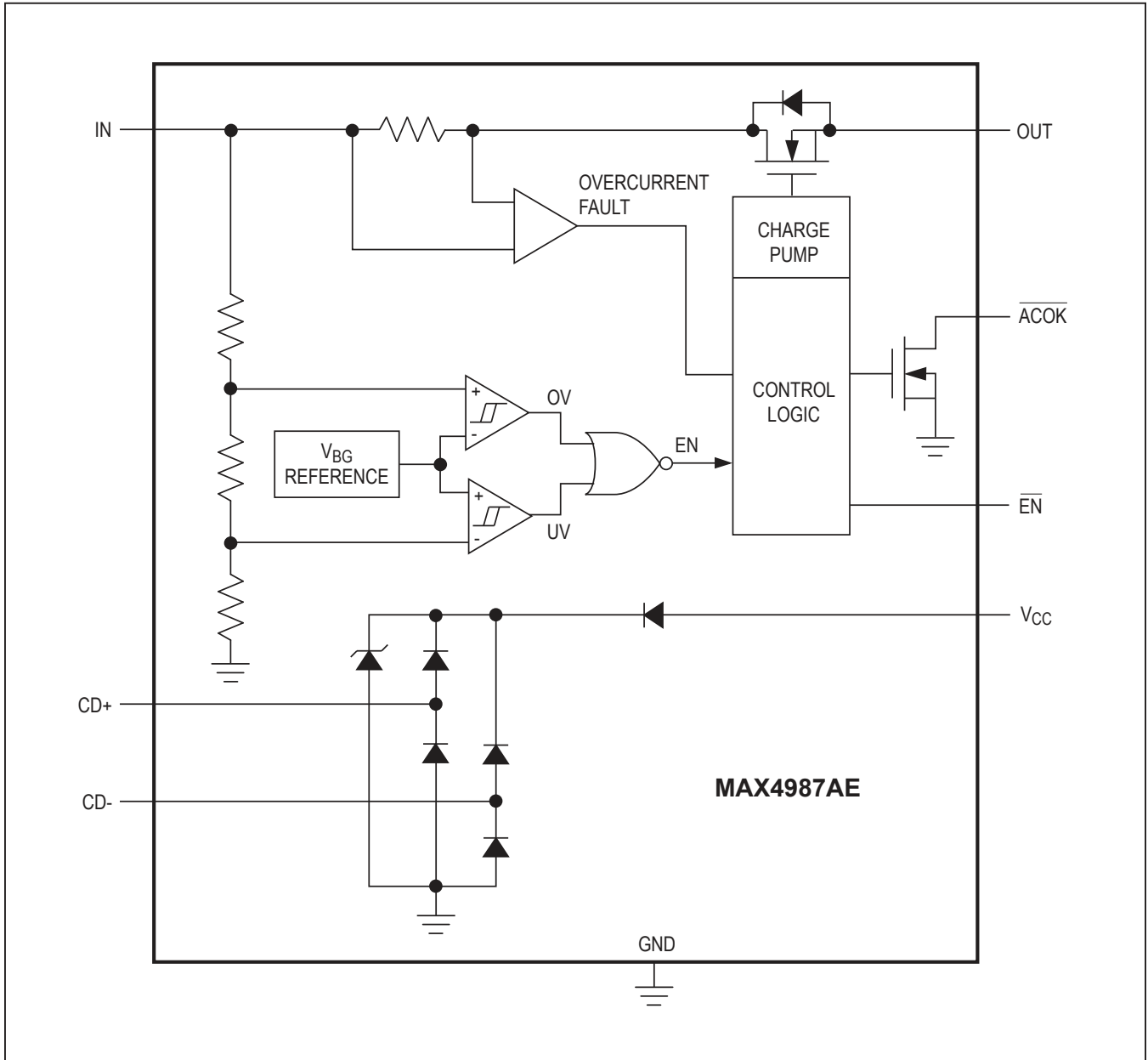

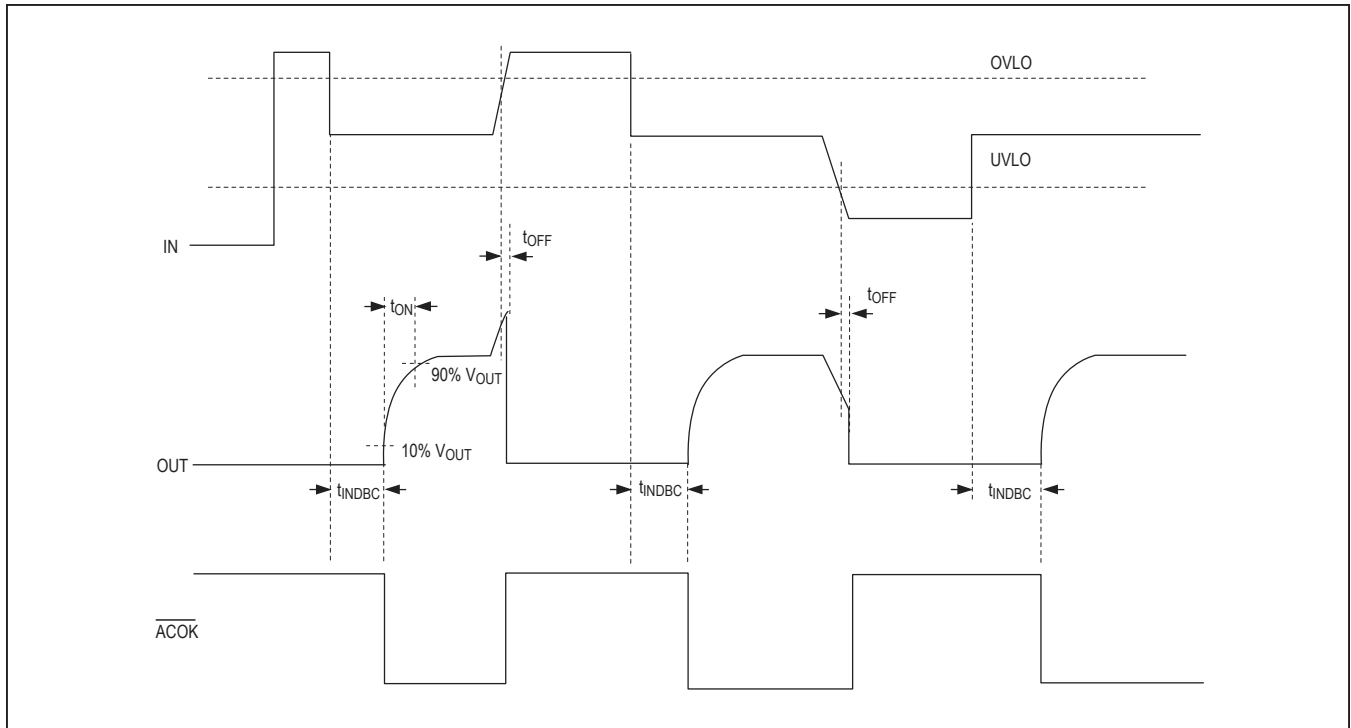

Figure 1. MAX4987AE Timing Diagram

Detailed Description

The MAX4987AE are overvoltage protection devices with integrated ESD protection for USB data lines. These devices feature a low R_{ON} internal FET and protect low-voltage systems against voltage faults up to +28V. If the input voltage exceeds the overvoltage threshold, the internal nFET switch is turned off to prevent damage to the protected components. The 30ms debounce time prevents false turn-on of the internal nFET switch during startup. An open-drain active-low logic output is available to signal that a successful power-up has occurred.

Device Operation

The MAX4987AE have an internal oscillator and charge pump that control the turn-on of the internal nFET switch. The internal oscillator controls the timers that enable the turn-on of the charge pump and controls the state of the open-drain \overline{ACOK} output. If $V_{IN} < V_{UVLO}$ or if $V_{IN} > V_{OVLO}$, the internal oscillator remains off, thus disabling the charge pump. If $V_{UVLO} < V_{IN} < V_{OVLO}$, the internal charge pump is enabled. The charge-pump startup, after a 30ms internal delay, turns on the internal nFET switch and asserts \overline{ACOK} (see Figure 1). At any time, if V_{IN} drops below V_{UVLO} or rises above V_{OVLO} , \overline{ACOK} is pulled high and the charge pump is disabled.

Internal nFET Switch

The MAX4987AE incorporate an internal nFET switch with a 100m Ω (typ) on-resistance. The nFET switch is internally driven by a charge pump that generates a voltage above the input voltage. The MAX4987AE is equipped with a 1.5A (min) current-limit protection that turns off the nFET switch within 5 μ s (typ) during an over-current fault condition.

Autoretry

The MAX4987AE have an overcurrent autoretry function that turns on the nFET switch again after a 30ms (typ) retry time (see Figure 2). If the faulty load condition is still present after the blanking time, the switch turns off again and the cycle is repeated. The fast turn-off time and 30ms retry time result in a very low duty cycle in order to keep power consumption low. If the faulty load condition is not present, the switch remains on.

Undervoltage Lockout (UVLO)

The MAX4987AE has a 2.55V undervoltage-lockout threshold (UVLO). When V_{IN} is less than V_{UVLO} , \overline{ACOK} is high impedance.

Overvoltage Lockout (OVLO)

The MAX4987AE have a 6.15V (typ) overvoltage threshold (OVLO). When V_{IN} is greater than V_{OVLO} , \overline{ACOK} is high impedance.

\overline{ACOK}

\overline{ACOK} is an active-low open-drain output that asserts low when $V_{UVLO} < V_{IN} < V_{OVLO}$ following the 30ms (typ) debounce period. Connect a pullup resistor from \overline{ACOK} to the logic I/O voltage of the host system. During a short-circuit fault, \overline{ACOK} may deassert due to V_{IN} not being in the valid operating voltage range.

Thermal-Shutdown Protection

The MAX4987AE feature thermal-shutdown circuitry. The internal nFET switch turns off when the junction temperature exceeds T_{SHDN} and immediately goes into a fault mode. The device exits thermal shutdown after the junction temperature cools by +40°C (typ).

Applications Information

IN Bypass Capacitor

For most applications, bypass IN to GND with a 1µF ceramic capacitor as close to the device as possible to enable ±15kV HBM ESD protection on IN. If ±15kV HBM ESD protection is not required, there is no capacitor required at IN. If the power source has significant inductance due to long lead length, take care to prevent overshoots due to the LC tank circuit and provide protection if necessary to prevent exceeding the absolute maximum rating on IN.

ESD Test Conditions

ESD performance depends on a number of conditions. The MAX4987AE are specified for ±15kV HBM ESD protection on the CD+, CD-, and IN pins when IN is bypassed to ground with a 1µF ceramic capacitor. The CD+ and CD- inputs are also protected against ±15kV airgap and ±6kV contact IEC61000-4-2 ESD events.

Human Body Model

Figure 3 shows the Human Body Model, and Figure 4 shows the current waveform it generates when discharged into a low impedance. This model consists of a 100pF capacitor charged to the ESD voltage of interest, that is then discharged into the device through a 1.5kΩ resistor.

IEC 61000-4-2

The IEC 61000-4-2 standard covers ESD testing and performance of finished equipment. It does not specifically refer to integrated circuits. The MAX4987AE are

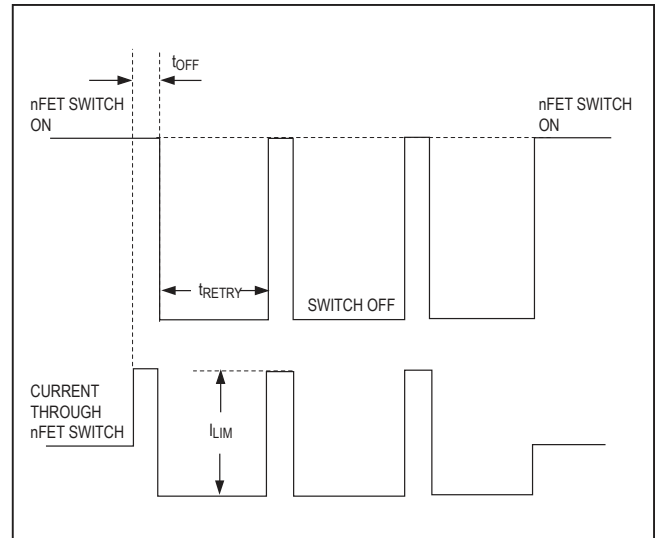

Figure 2. Autoretry Timing Diagram

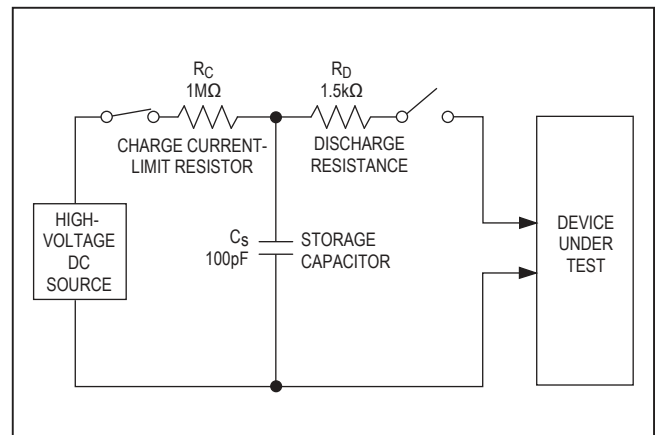

Figure 3. Human Body ESD Test Model

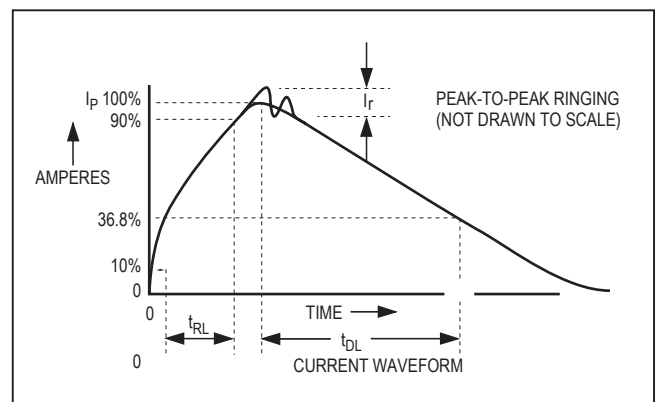

Figure 4. Human Body Current Waveform

MAX4987AE

Overvoltage-Protection Controller with USB ESD Protection

specified for ±15kV Air-Gap Discharge and ±6kV Contact Discharge IEC 61000-4-2 on the CD+ and CD- pins.

The major difference between tests done using the Human Body Model and IEC 61000-4-2 is a higher peak current in IEC 61000-4-2, due to lower series resistance. Hence, the ESD withstand voltage measured to IEC 61000-4-2 generally is lower than that measured using the Human Body Model. Figure 5 shows the IEC 61000-4-2 model. The Contact Discharge method connects the probe to the device before the probe is charged. The Air-Gap Discharge test involves approaching the device with a charged probe.

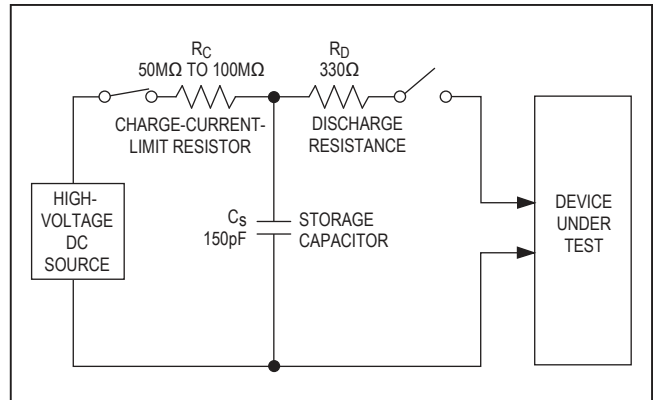
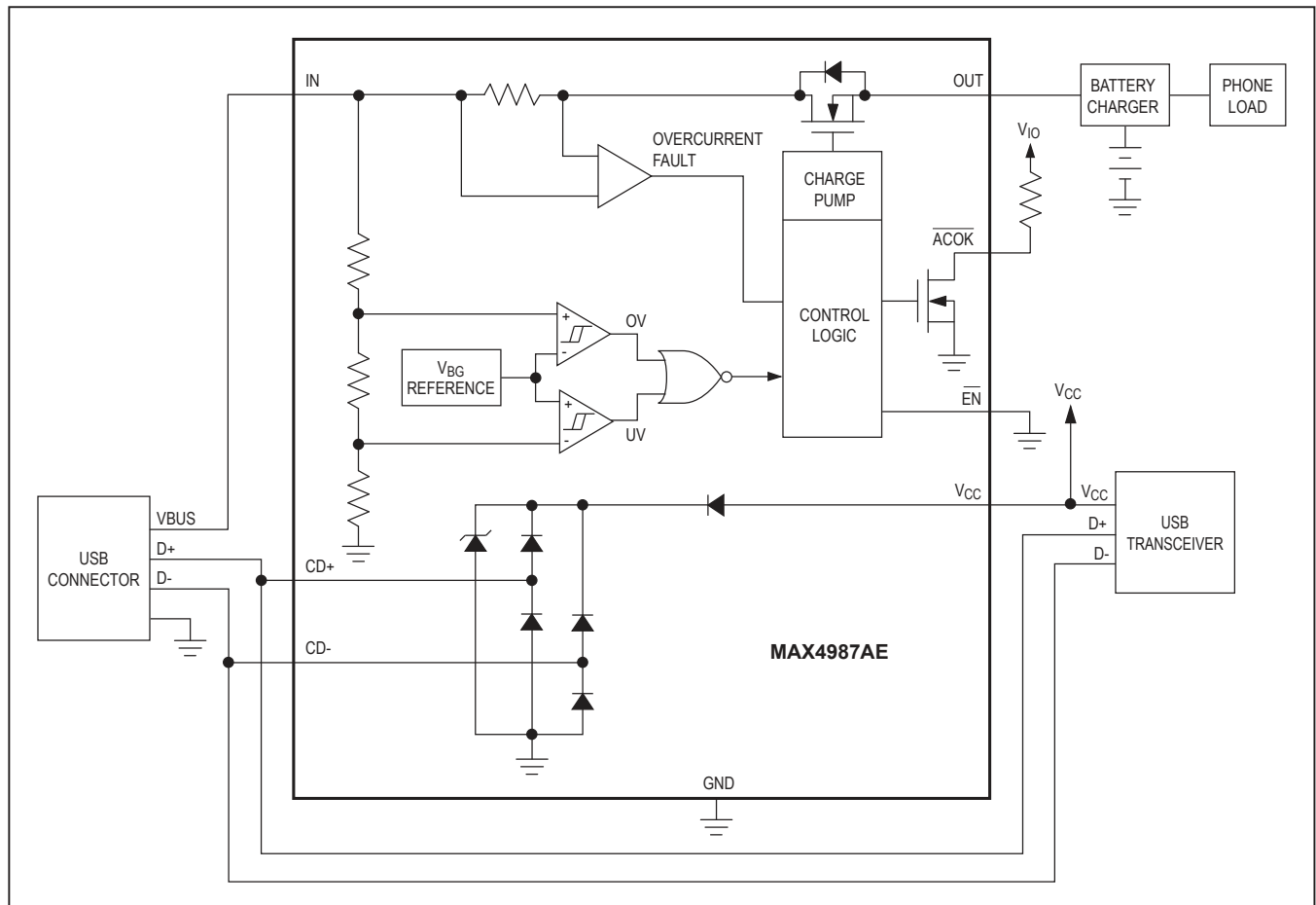

Figure 5. IEC 61000-4-2 ESD Test Model

Typical Operating Circuit



Ordering Information

PART	PIN-PACKAGE	TOP MARK	PACKAGE CODE	UVLO (V)	OVLO (V)	OVERCURRENT MODE
MAX4987AEETA+	8 TDFN-EP*	AAI	T823-1	2.55	6.15	Autoretry

Note: All devices are specified over the -40°C to +85°C operating temperature range.

+Denotes a lead-free package.

*EP = Exposed paddle.

Chip Information

PROCESS: BiCMOS

Revision History

REVISION NUMBER	REVISION DATE	DESCRIPTION	PAGES CHANGED
0	11/07	Initial release	—
1	4/19	Removed all MAX4987BE references	1–9

For pricing, delivery, and ordering information, please visit Maxim Integrated's online storefront at <https://www.maximintegrated.com/en/storefront/storefront.html>.

Maxim Integrated cannot assume responsibility for use of any circuitry other than circuitry entirely embodied in a Maxim Integrated product. No circuit patent licenses are implied. Maxim Integrated reserves the right to change the circuitry and specifications without notice at any time. The parametric values (min and max limits) shown in the Electrical Characteristics table are guaranteed. Other parametric values quoted in this data sheet are provided for guidance.