

THIS COPY IS PROVIDED ON A RESTRICTED BASIS AND IS NOT TO BE USED IN ANY WAY DETRIMENTAL TO THE INTERESTS OF PANDUIT CORP.

PANDUIT PART #	MILITARY PART # AND CLASS	STUD SIZE		DIMENSIONS in. [mm]				
		ENGLISH	METRIC	L ± .04 [1,0]	W ± .01 [0,3]	C ± .02 [0,5]	M ± .04 [1,0]	H ± .01 [0,3]
PMN6-3R	-----	--	M3	.97 [24,7]	.23 [5,8]	.31 [7,9]	.86 [21,8]	.13 [3,3]
PN10-6R	MS25036-111 CLASS 2	#6	M3,5	1.06 [27,0]	.38 [9,7]	.31 [7,9]	.88 [22,4]	.15 [3,8]
PN10-8R	MS25036-156 CLASS 2	#8	M4	1.21 [30,7]	.38 [9,7]	.31 [7,9]	.88 [22,4]	.17 [4,3]
PN10-10R	MS25036-112 CLASS 2	#10	--	1.06 [27,0]	.38 [9,7]	.31 [7,9]	.88 [22,4]	.20 [5,1]
PMN6-5R	-----	--	M5	1.04 [26,4]	.38 [9,7]	.31 [7,9]	.86 [21,8]	.21 [5,3]
PN10-14R	MS25036-157 CLASS 2	1/4"	M6	1.21 [30,7]	.52 [13,2]	.38 [9,7]	.95 [24,1]	.27 [6,9]
PN10-56R	MS25036-113 CLASS 2	5/16"	M8	1.21 [30,7]	.52 [13,2]	.38 [9,7]	.95 [24,1]	.33 [8,4]
PN10-38R	MS25036-114 CLASS 2	3/8"	--	1.29 [32,8]	.58 [14,7]	.43 [10,9]	.95 [25,4]	.39 [9,9]

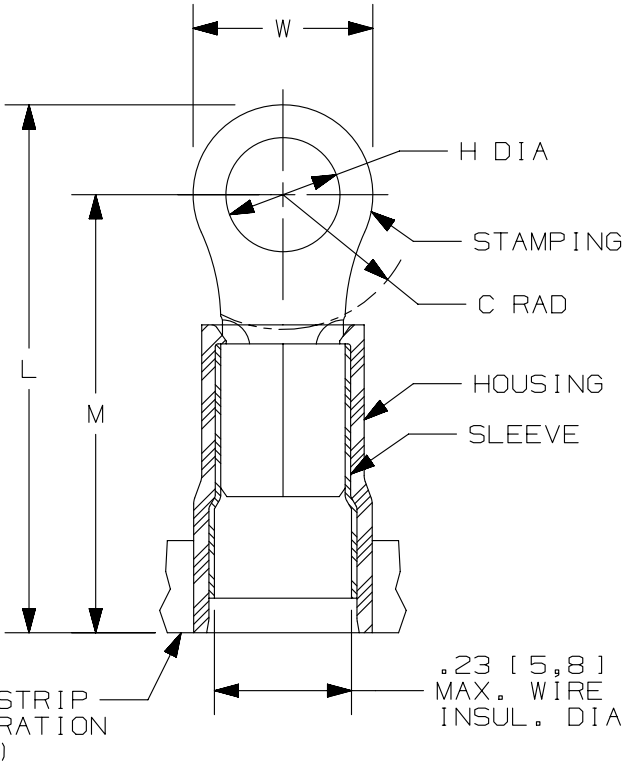

NOTES:

- USED FOR:
 - A. #12-10 AWG [4,0-6,0 mm²] SOLID OR STRANDED COPPER WIRE
 - B. 221°F [105°C] MAX. OPERATING TEMPERATURE
 - C. 600 V. MAX. VOLTAGE RATING
- INSTALLATION TOOLS:
 - A. PRESSES : CP-861, CP-871
 - B. APPLICATOR: CA-800, CA-9
 - C. DIE INSERTS: CD-800-3, CD9-3
- WIRE STRIP LENGTH: 9/32" ^{+1/32} [7,1^{+0,8}]
- MATERIAL:
 - A. STAMPING: .04" [1,02] THK COPPER, TIN PLATED
 - B. HOUSING: NYLON, YELLOW
 - C. SLEEVE: BRASS, TIN PLATED
- SEE www.panduit.com FOR PACKAGE QUANTITIES INDICATED BY PART NUMBER SUFFIX
- DIMENSIONS IN BRACKETS ARE METRIC EQUIVALENT



LISTED
587H
E52164

CERTIFIED
LR31212

REV	DATE	BY	CHK	APR	DESCRIPTION	ECN
08	09.18.12	JBN	LCA	VMB	ADDED METRIC EQUIVALENT. REVISED NOTES. UPDATED DRAWING TO CURRENT STANDARDS.	A41098

TITLE RING TERMINALS, 3PC. NYLON INSULATED, #12-10 CUSTOMER DRAWING	
ITEM REVISION NAME N41098BA/08	PANDUIT
DATASET FILE NAME N41098BA_DC/08A	
UNLESS OTHERWISE SPECIFIED, DIMENSIONAL TOLERANCES ARE: IN [mm] .x ± .1 [2.54] .xxx ± .005 [.13] .xx ± .01 [.25] ANGLES ± 5°	
MATERIAL: SEE NOTES	
DRAWING NUMBER: A41098	
DRAWN BY JMV	DATE -
CHK FS	SCALE N.T.S.
SHT 1 OF 1	
A	

D101000DA/15