

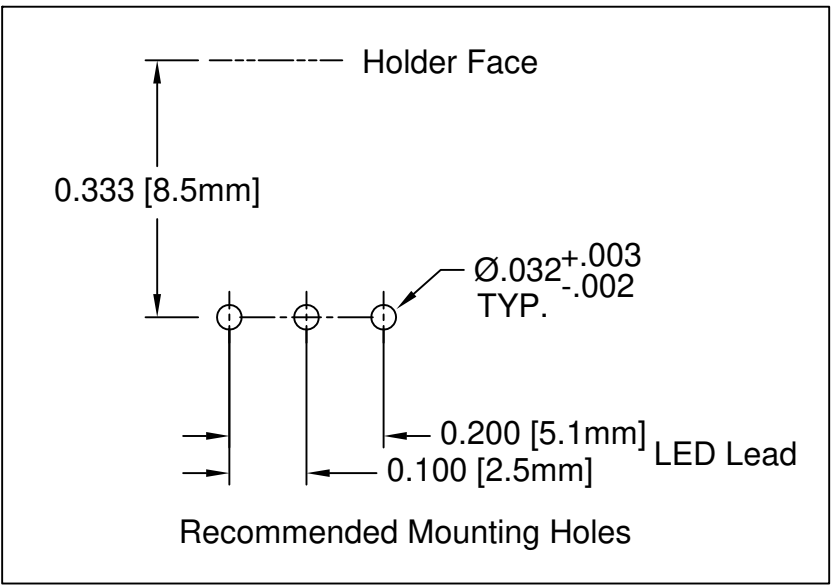

REV.	DESCRIPTION	DATE	APPROVED
B	Engineering Update w/o Changes	02/23/04	M. C.
C	Updated Recommended Mounting Holes	08/31/07	M. C.
D	Removed Material Code	05/28/16	J. C.

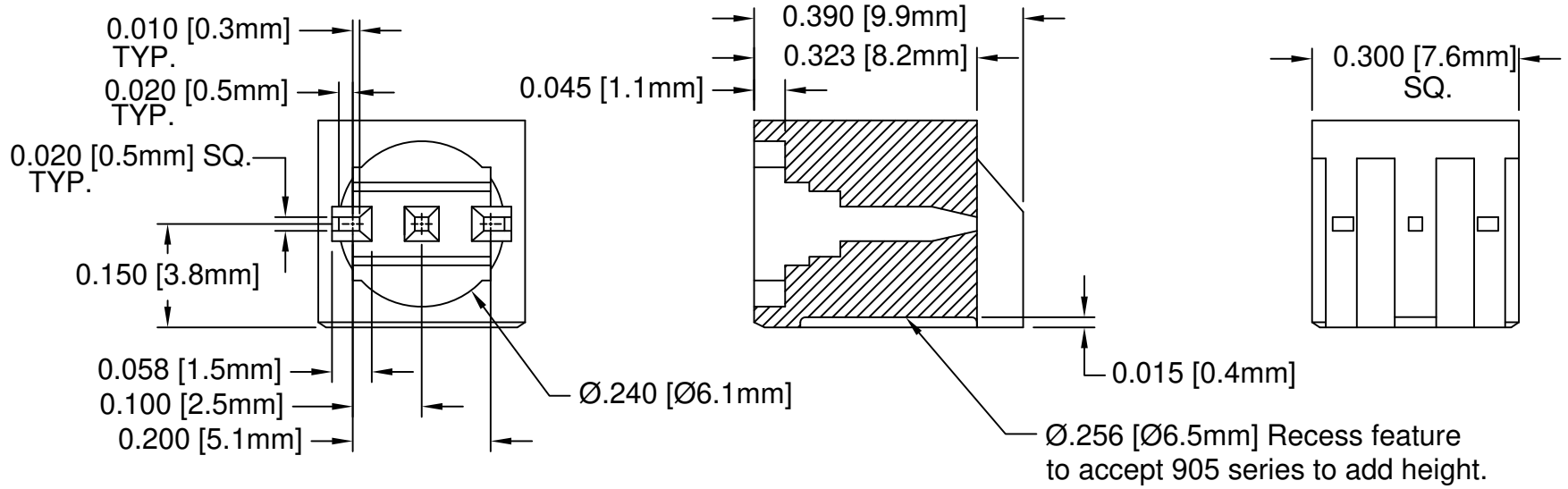

- 2. MATERIAL: NYLON 6/6, 94V-2, NATURAL.
- 1. GENERAL SPECIFICATIONS: BIVAR MOLDED COMPONENT SPECIFICATION BV00-E101.

STANDARD TOLERANCE (UNLESS OTHERWISE SPECIFIED)		 4 THOMAS, IRVINE, CA. 92618 TEL: (949) 951-8808 FAX: (949) 951-3974	
DECIMALS	ANGULAR		
.X ±.1	X° ± 1°		TITLE: SINGLE T-1(3mm) LED HOLDER
.XX ±.01			PART NO: 920-300
.XXX ±.005			REVISION: D
DESIGNED: D. Green	DATE: 07/14/03	CAGE CODE : 32559	SHEET # 1 OF 1
CHECKED: M. Chen	DATE: 07/14/03	CAD GENERATED DOCUMENT, DO NOT MEASURE DRAWING.	