

MS Lithium-Ion Rechargeable Battery <3V Type>

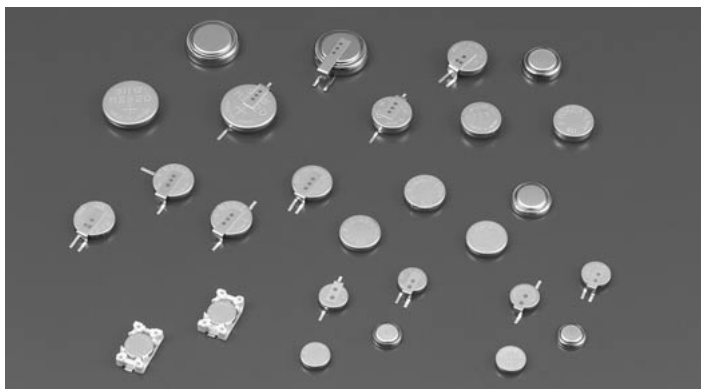

SII own developed MS(Manganese Silicon) Lithium-ion rechargeable battery addresses the demand most effectively. The battery uses silicon oxide as anode and lithium manganese composite oxide as cathode. As a result, it offers twenty times the capacity of conventionally available batteries, in addition to longer cycle-life and highly stable over-discharge characteristics.

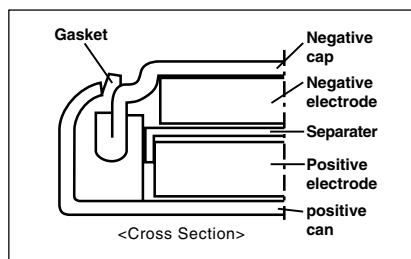

FEATURES

- Large discharge capacity:
Large discharge capacity for high operational voltage range of 2.0V to 3.3V.
- Long cycle-life:
Over 200 times cycle-life under the charge/discharge condition at 2.0V to 3.3V (D.O.D 100%).
- Excellent over-discharge characteristics:
Continued stable capacity characteristics after the battery is over-discharged down to 0.0V.
- Approved product by UL
Manganese Silicon Lithium-ion Battery (MS series) is approved by UL(Underwriters Laboratories Inc.)
UL File MH 15628
MS412F/MS414/MS614/MS614F/MS614S/
MS621/MS621F/MS920/MS920S/ (MS421S)

APPLICATIONS

- Back up power supply for memory or clock in various electronic equipment e.g. cellular-phones, cordless phones, PHS, pagers, memory-cards, FAX machines, personal computers, PDA, Video cameras, digital cameras, tuners, handy terminals etc.
- Combined use with solar cells.
- Main power source for small and slim portable equipment.

SPECIFICATIONS

Type	Nominal Voltage (v)	Nominal Capacity (mAh)	Internal Resistance (Ω)*1	Standard Charge/Discharge Current (mAh)	Maximum Discharge/Current (continuous) (mA)*2	Cycle Life (Times)*3		Standard Charge Voltage (V)	Size(mm)		Weight (g)
						100% D.O.D (Depth of Discharge)	20% D.O.D (Depth of Discharge)		Diameters	Height	
MS412F	3	1.0	100	0.010	0.15	200	1000	3.1	4.8	1.2	0.07
MS414	3	0.25	100	0.010	0.15	200	1000	3.3	4.8	1.4	0.07
MS414F	3	1.2	100	0.005	0.15	200	1000	3.1	4.8	1.4	0.07
(New) MS421S	3	2.5	160	0.010	0.15	100	1000	3.1	4.8	2.1	0.11
MS614	3	2.3	50	0.025	0.50	200	1000	3.3	6.8	1.4	0.17
MS614F	3	3.0	80	0.025	0.50	200	1000	3.1	6.8	1.4	0.16
MS614S	3	3.4	80	0.025	0.50	200	1000	3.1	6.8	1.4	0.17
MS621	3	4.0	50	0.025	0.50	200	1000	3.3	6.8	2.1	0.23
MS621F	3	5.5	80	0.025	0.50	200	1000	3.1	6.8	2.1	0.23
MS920	3	8.0	35	0.050	1.00	200	1000	3.3	9.5	2.1	0.46
(New) MS920S	3	11.0	35	0.050	0.80	100	1000	3.1	9.5	2.1	0.47
(Developing) MS1220S	3								12.5	2.0	

*1 Internal resistance is measured using AC (Alternating Current) method.

(24°C, 3.3V to 2.0V / 3.1V to 2.0V(F, S type))

*2 Maximum discharge current indicates the value of current for approximately 50% of nominal capacity.

*3 100% and 20% D.O.D are based on nominal capacity.

Principle System of MS Lithium-Ion Rechargeable Battery

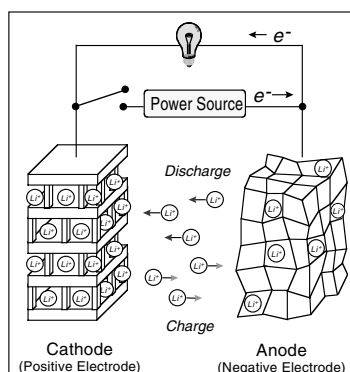

Anode (negative electrode) Lithium silicon composite oxide developed by SII in our MS battery is :

- ① able to absorb a large quantity of Lithium ions.
- ② stable during Absorption (charging) and Release (discharging) of the Lithium ions

1. High Capacity

2. Long Cycle Life

More than 200 times cycle life under D.O.D (Depth of Discharge) 100%

3. Overdischarge Characteristics

Discharge Characteristics at Various Charge Voltage

MS412F

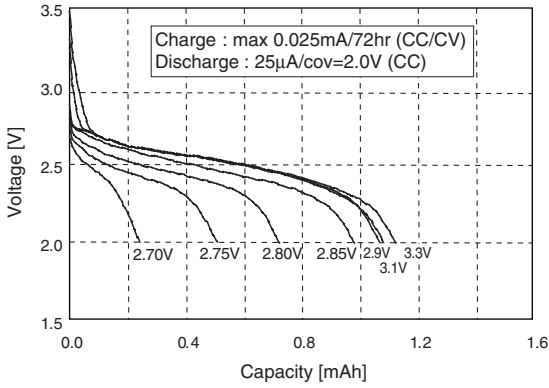

MS421S

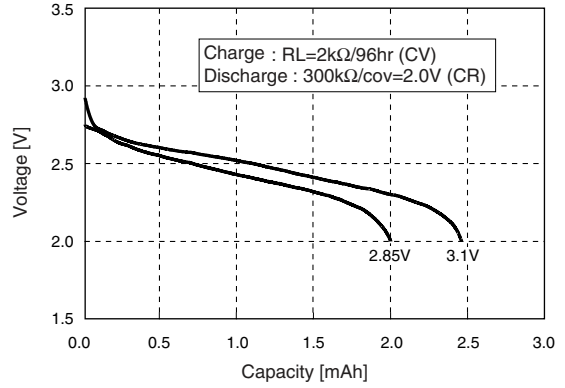

MS614

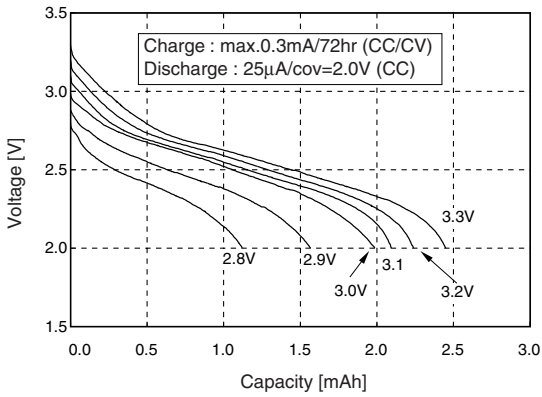

MS614S

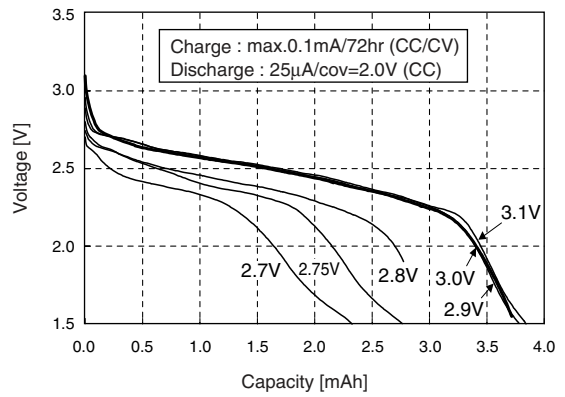

MS621

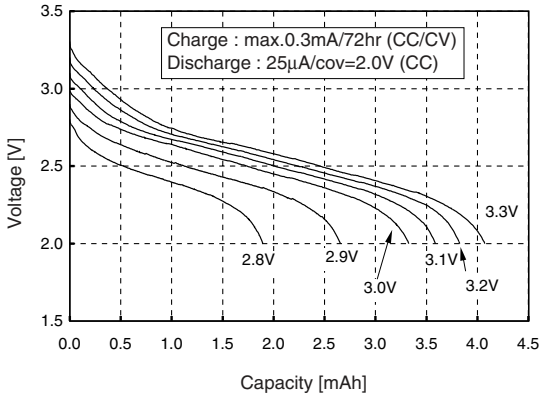

MS621F

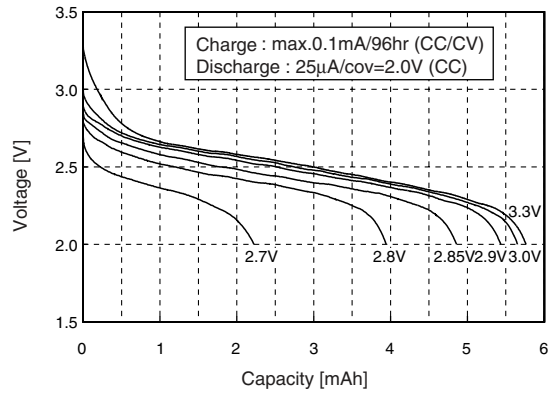

MS920

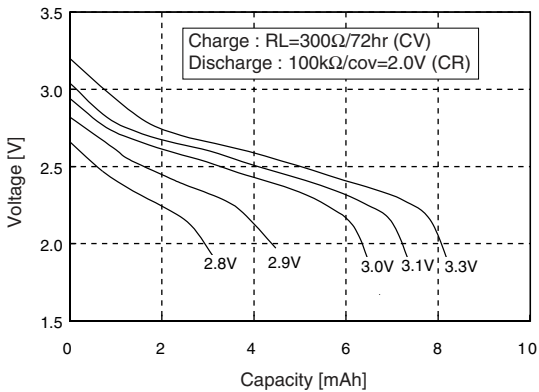

MS920S

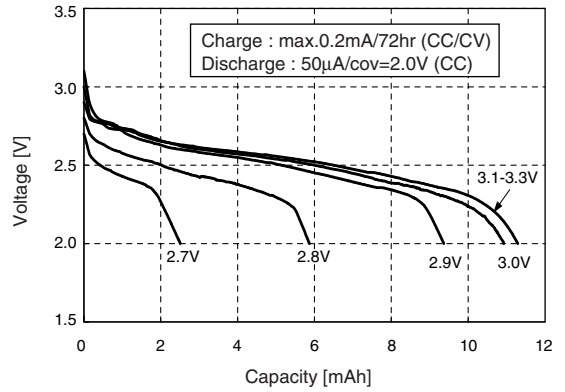

MS Lithium-Ion Rechargeable Battery <3V Type>

CHARACTERISTICS

MS621

Cycle Life-Depth of Discharge

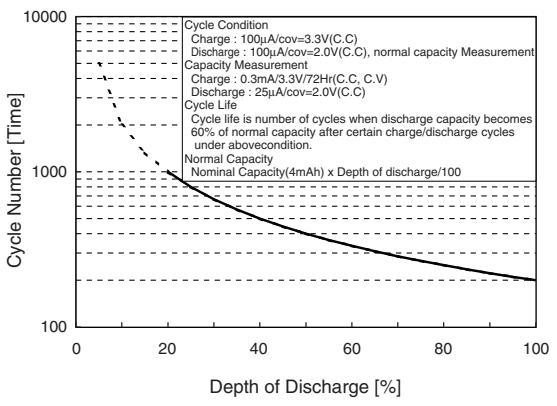

High Temperature Storage Characteristics(80°C)

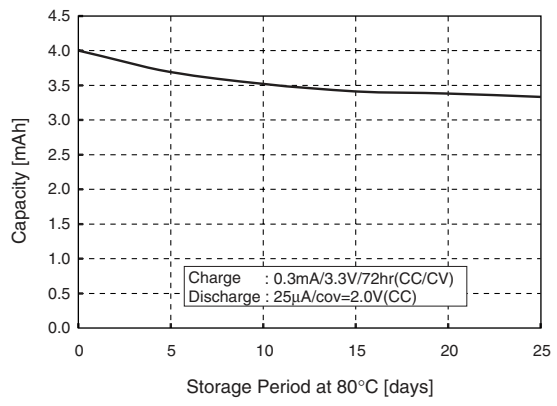

High Temperature Storage Characteristics(60°C)

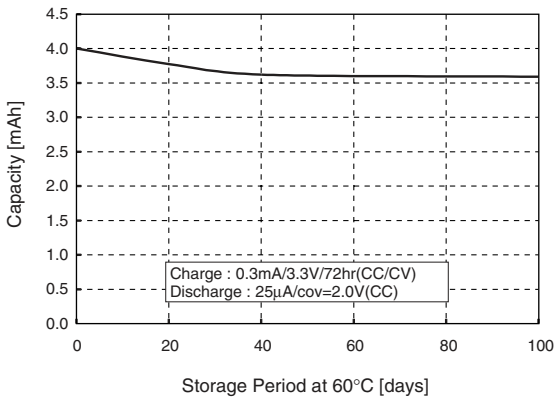

Over Discharge Characteristics

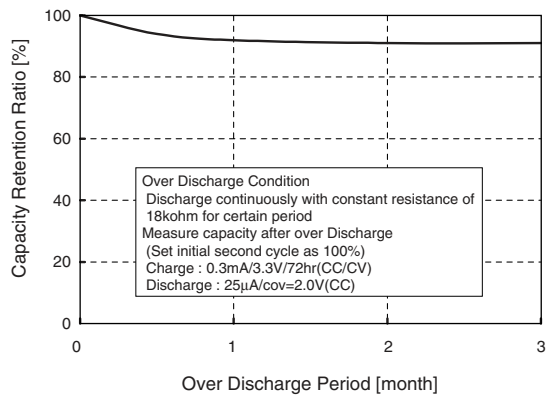

Over-Charge (Floating-Charge) Characteristics

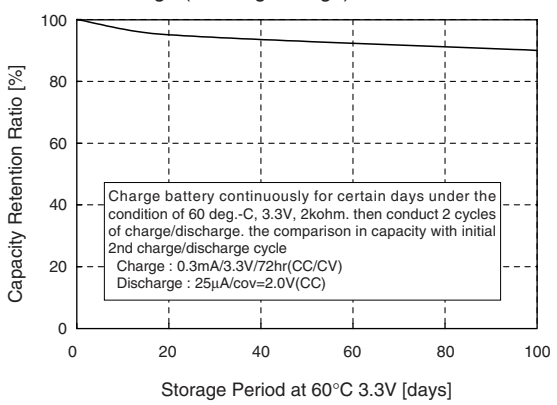

Self Discharge Characteristics

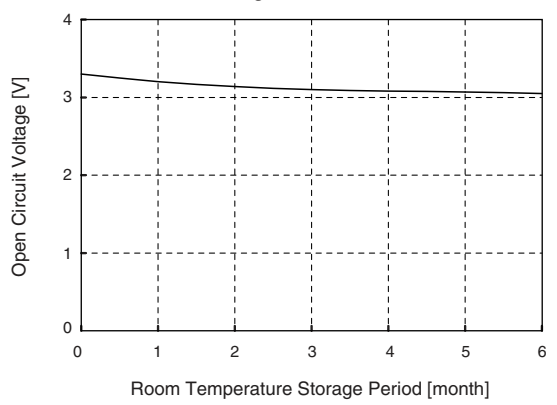

Temperature Characteristics (Capacity)

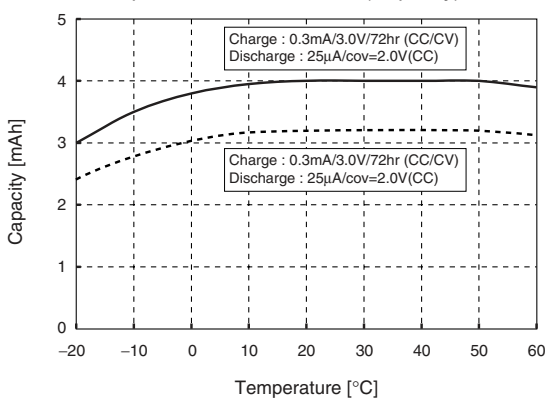

Temperature Characteristics (Internal Resistance (Ri ac))

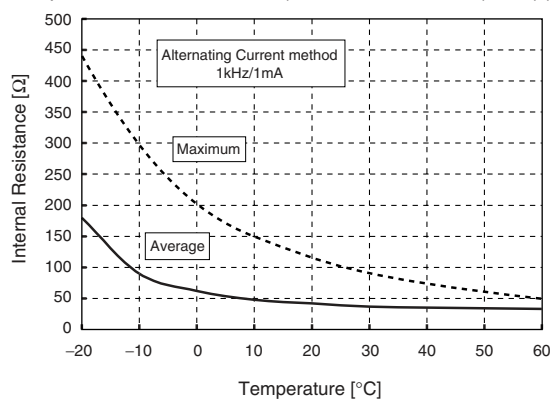

MS Lithium-Ion Rechargeable Battery <3V Type>

CHARGING CIRCUIT

◆ Standard Charging Circuit Settings List for Using MS Rechargeable Battery with Constant Voltage and Constant Resistance.

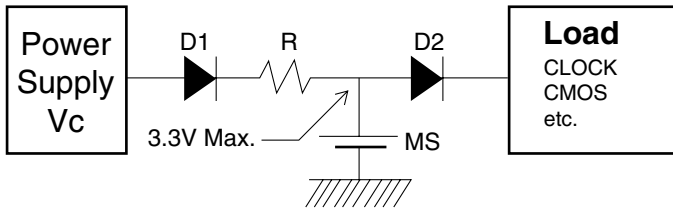

Charging Voltage : 3.3V Max.

Charging current limiting resistance : R

D1 : Diode (Item of smaller VF, IR is recommendable)

D2 : Using a schottky type of smaller VF will lead better performance

Type	Charging Voltage Range (V)	Recommendable Charging Current (mA) At Battery Voltage of 3.0V I_c	Maximum Charging Current (mA)	
			At the Battery Voltage of 3.0V I_u	At the Battery Voltage of 0V I_L
MS412F	2.7 to 3.3	0.08max.	0.15	2
MS414	2.7 to 3.3	0.08max.	0.15	2
MS421S	2.7 to 3.3	0.08max.	0.15	2
MS614, 614F, 614S	2.7 to 3.3	0.30max.	0.5	10
MS621, 621F	2.7 to 3.3	0.30max.	0.5	10
MS920	2.7 to 3.3	0.60max.	1.0	20
MS920S	2.7 to 3.3	0.40max.	0.5	10

As for the minimum limit resistance R, please use the value which satisfies the following two formula;

1) In the case a battery voltage is 3.0V:

$$R > (V_c - 3.0 - V_f) / I_u$$

2) In the case a battery voltage is 0V:

$$R > (V_c - V_f) / I_L$$

Also for the recommendable limit resistance, please use I_c instead of I_u in the formula 1).

◆ Circuit Example in the case of using 3V for Power Supply.

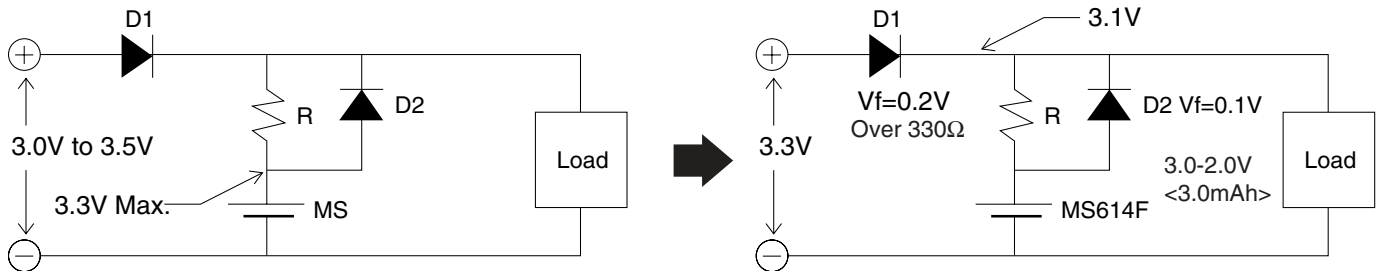

◆ Circuit Example in the case of using 5V for Power Supply.

(1) with using voltage regulator IC

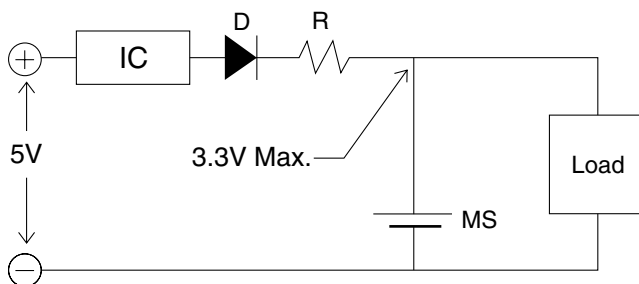

(2) with using Zener diode

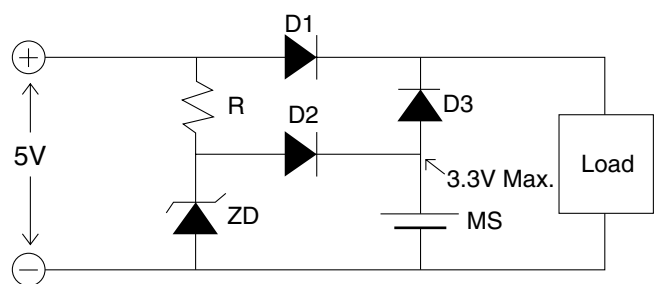

(3) with using charge/discharge control IC

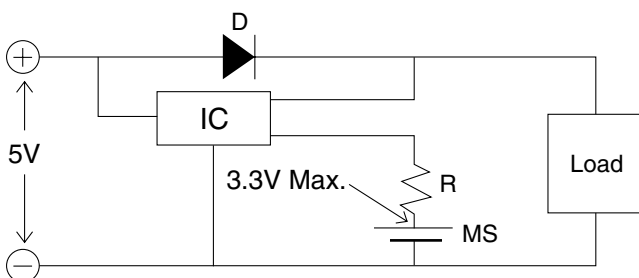

(4) with using divided resistance for voltage

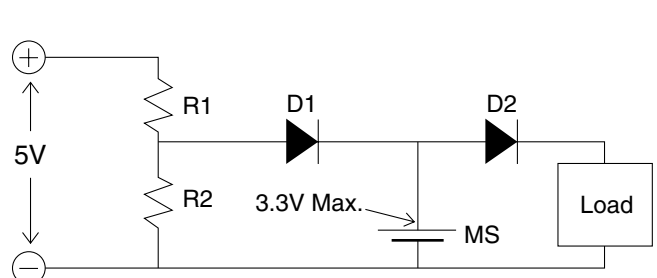

MS Lithium-Ion Rechargeable Battery <3V Type>

■ DIMENSIONS OF STANDARD TAB-WELD FOR MANGANESE SILICON LITHIUM-ION BATTERY

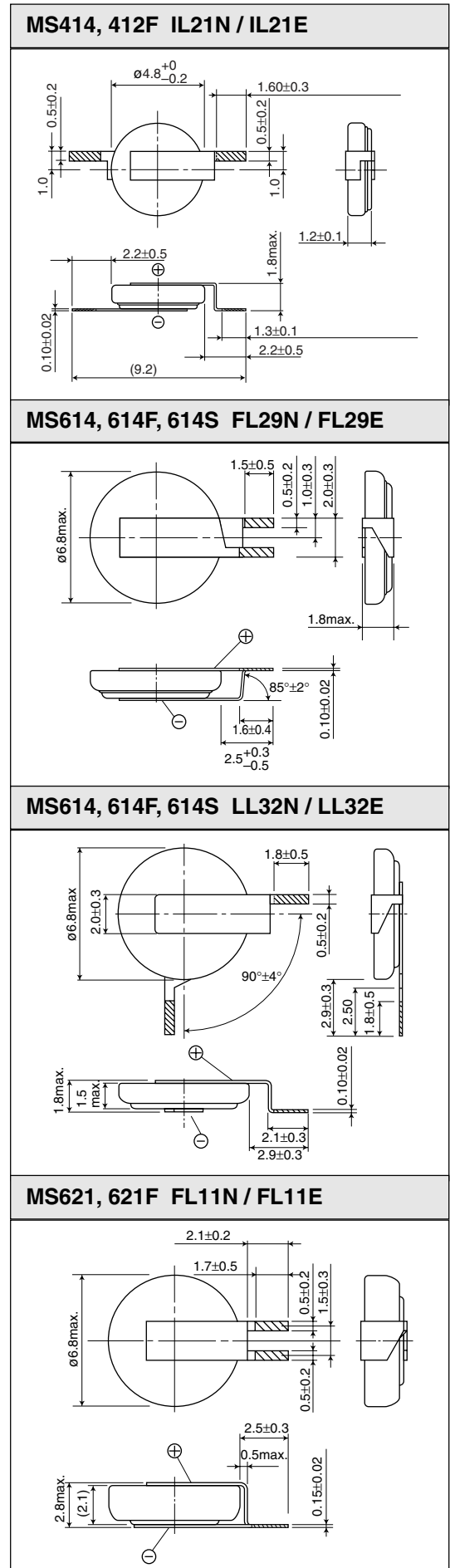
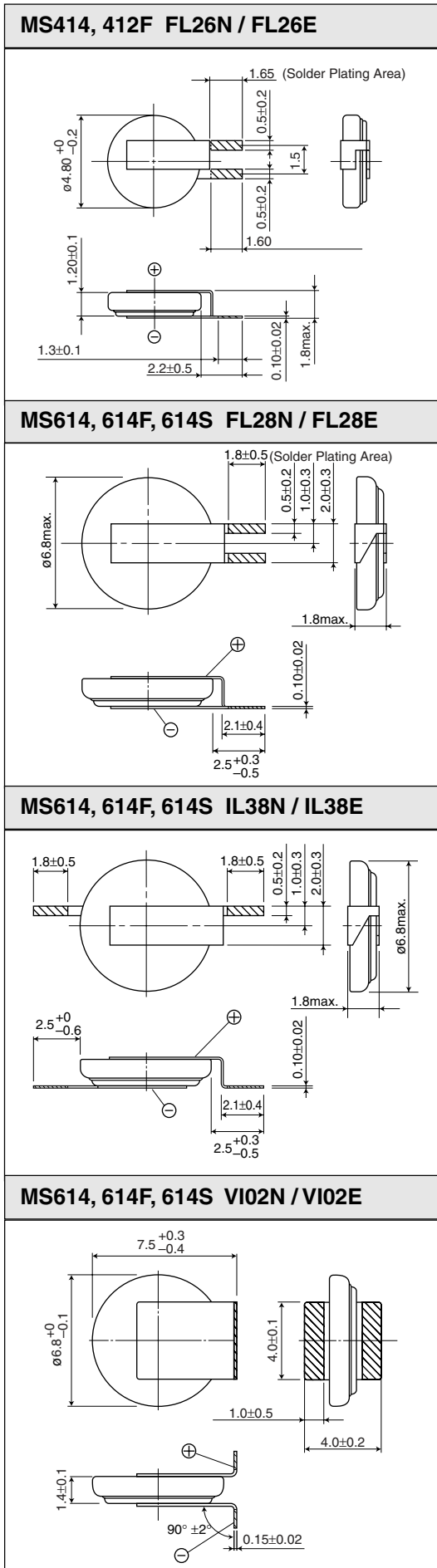

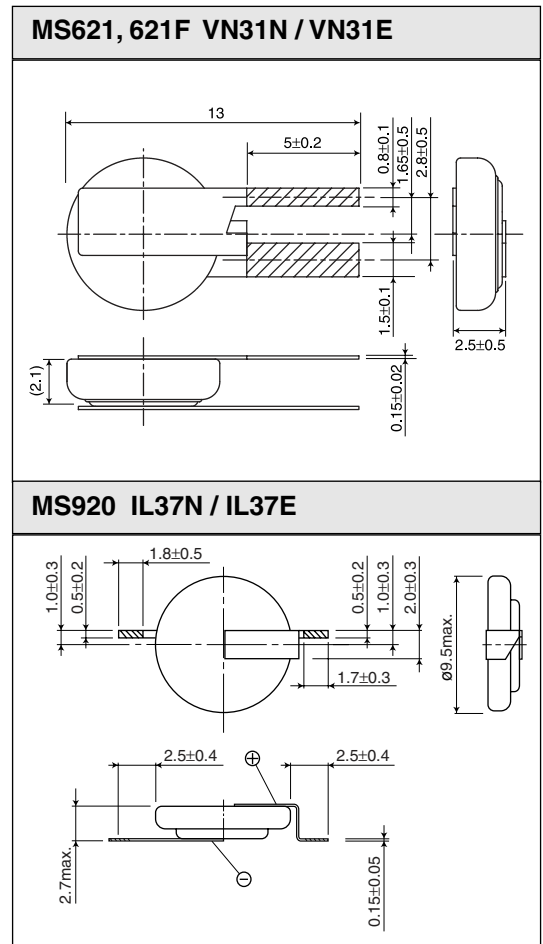
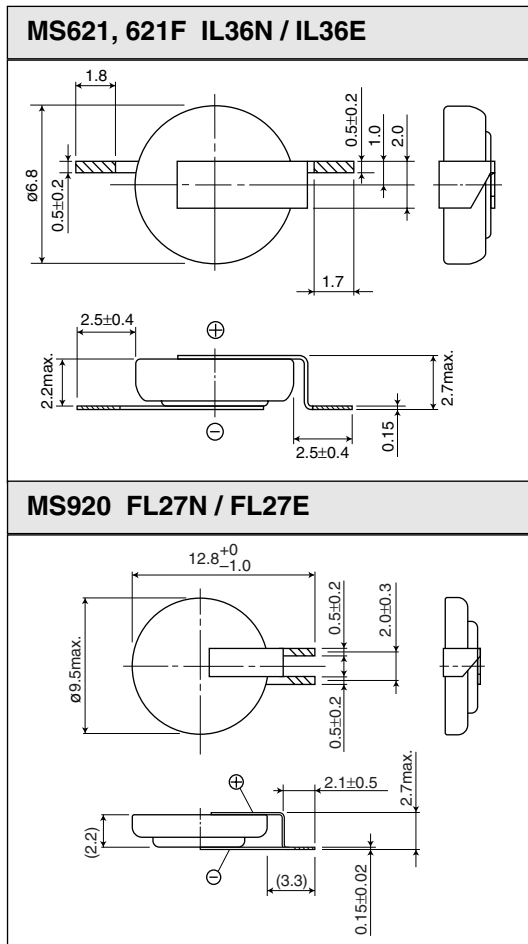

- Hatched parts are solder plated. (N type: Pb 10% Sn 90%) (E type: Sn 100%)
- The E type is plated by Pb-free solder. We are going to discontinue N type soon.
- For any optional terminal shapes, please consult with us.
- Unit of dimensions: mm

BATTERY HOLDER

BH0414

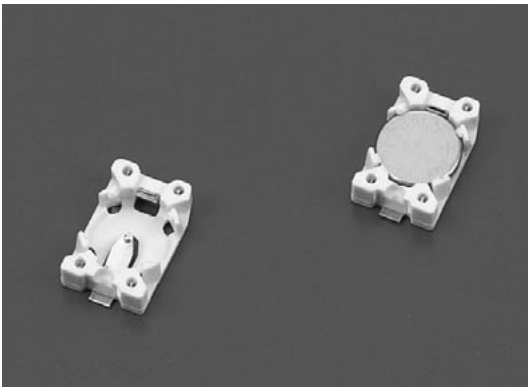

Using precision technology the holder realizes less-space and high reliability and obtains high mounting functionality.

<Specifications>

Item	Standard
With Standing Voltage	DC500V/minute
Contact Resistance	Less than 100mΩ
Insulation Resistance	More than 100MΩ
Operational Temperature Range	-40°C ~ +85°C

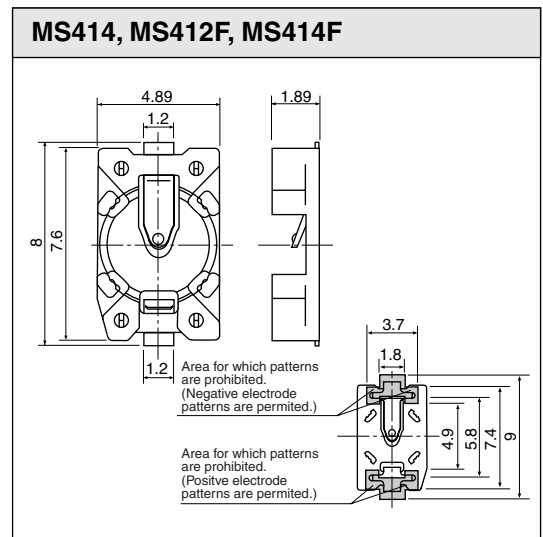

<Applicable Batteries>

MS414, MS412F, MS414F

<Features>

- Thin: 1.89mm Height after mounting
- Easy for Automatic mounting:
Able to insert battery vertically
- Embossed Tape Package