

DO NOT SCALE FROM THIS PRINT

DESIGNED & DIMENSIONED IN MILLIMETERS [INCHES]

SMA-J-C-X-ST-BR2
 GENDER -J: JACK
 TYPE -C: CABLE
 TERMINATION -BR2: REVERSE POLARITY BULKHEAD (RG178)
 ORIENTATION -ST: STRAIGHT
 PLATING SPECIFICATION -H: 30μ" GOLD CENTER CONTACT, 3μ" GOLD OUTER CONTACT (SEE TABLE 1)

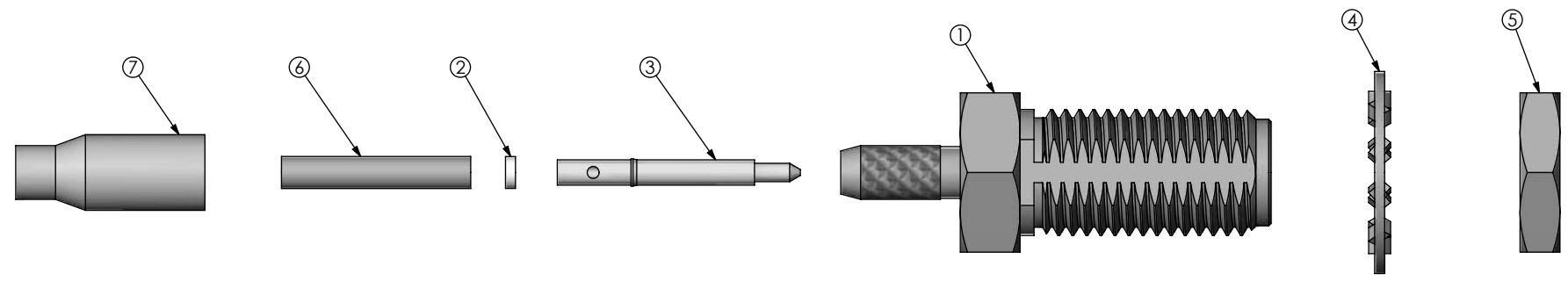
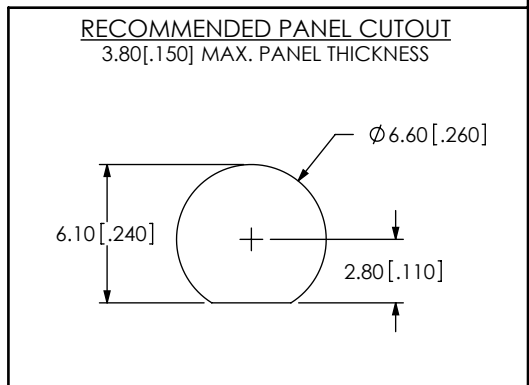

TABLE 1

ITEM	COMPONENT	-H
1	SUB-ASSEMBLY	SUB-SMA-J-C-F-ST-BH1
2	INSULATOR	SMA-INS-001
3	PIN	SMA-PIN-005-H
4	LOCK WASHER	SMA-LWAS-001-F
5	NUT	SMA-NUT-001-F
6	INNER FERRULE	SMA-FER-003-N
7	OUTER FERRULE	MCX-FER-004-F



- NOTES:
- NOTE DELETED.
 - NOTE DELETED.
 - PRODUCT TO BE BULK PACKAGED PER PACKAGING STANDARD CO-RF-WI-3040-M.
 - NUT AND WASHER TO BE PACKAGED SEPARATELY.

UNLESS OTHERWISE SPECIFIED, DIMENSIONS ARE IN MILLIMETERS. TOLERANCES ARE: DECIMALS ANGLES X.X: ±0.3 [.01] 5° X.XX: ±0.13 [.005] X.XXX: ±0.051 [.0020]	* PROPRIETARY NOTE * THIS DOCUMENT CONTAINS CONFIDENTIAL AND PROPRIETARY INFORMATION AND ALL DESIGN, MANUFACTURING, REPRODUCTION, USE, PATENT RIGHTS AND SALES RIGHTS ARE EXPRESSLY RESERVED BY SAMTEC, INC. THIS DOCUMENT SHALL NOT BE DISCLOSED, IN WHOLE OR PART, TO ANY UNAUTHORIZED PERSON OR ENTITY NOR REPRODUCED, TRANSFERRED OR INCORPORATED IN ANY OTHER PROJECT IN ANY MANNER WITHOUT THE EXPRESS WRITTEN CONSENT OF SAMTEC, INC.		
		520 PARK EAST BLVD., NEW ALBANY, IN 47150 PHONE: 812-944-6733 FAX: 812-948-5047 e-Mail: info@SAMTEC.com code 55322	
MATERIAL: DO NOT SCALE DRAWING SHEET SCALE: 3:1		DESCRIPTION: 50 OHM, SMA STRAIGHT JACK REVERSE POLARITY BULKHEAD, RG178	
PIN: BeCu BODY: PHOS BRONZE INSULATOR: PTFE		DWG. NO. SMA-J-C-X-ST-BR2	
		BY: R MUSSER 01/28/2008	SHEET 1 OF 2



IN-PROCESS 1
STRIP CABLE AND TIN INNER AND OUTER CONDUCTOR

INSULATOR SHOULD BE FLUSH TO CABLE INSULATOR

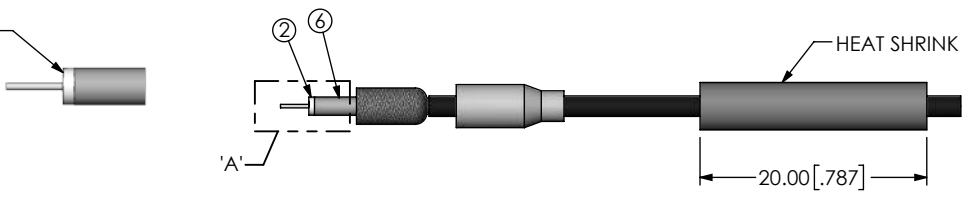

IN-PROCESS 2
ADD HEAT SHRINK TUBING AND OUTER FERRULE FLARE SHIELD, ADD INNER FERRULE & INSULATOR

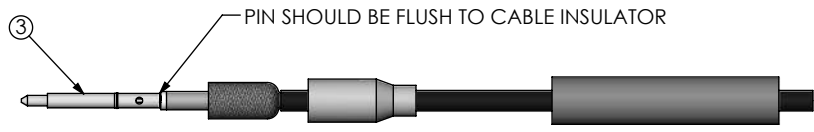

IN-PROCESS 3
SOLDER SIGNAL PIN

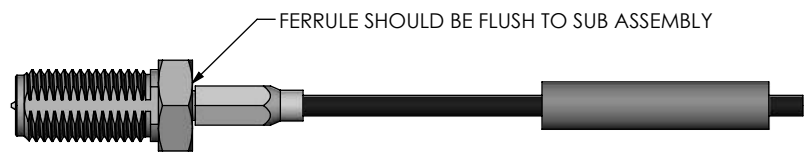

IN-PROCESS 4
ADD SUB ASSEMBLY
CRIMP FERRULE
(USE CRIMP HAND TOOL #CAT-RF-FER-001 AND DIE 0.136" INCH DESIGNATION SIZE)

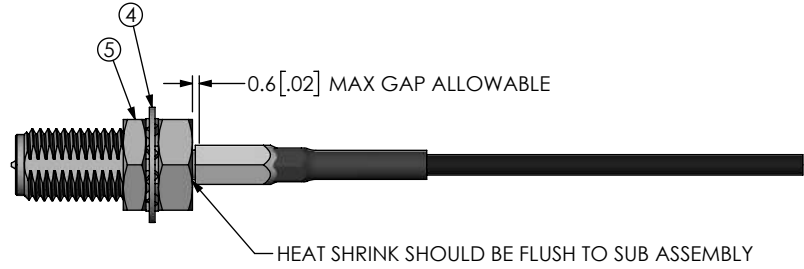

IN-PROCESS 5
ACTIVATE HEAT SHRINK TUBING & ADD GASKET

F:\DWG\MISC\MKTG\SMA-J-C-X-ST-BR2-MKT.SLDDRW

<p>PROPRIETARY NOTE</p> <p>THIS DOCUMENT CONTAINS CONFIDENTIAL AND PROPRIETARY INFORMATION AND ALL DESIGN, MANUFACTURING, REPRODUCTION, USE, PATENT RIGHTS AND SALES RIGHTS ARE EXPRESSLY RESERVED BY SAMTEC, INC. THIS DOCUMENT SHALL NOT BE DISCLOSED, IN WHOLE OR PART, TO ANY UNAUTHORIZED PERSON OR ENTITY NOR REPRODUCED, TRANSFERRED OR INCORPORATED IN ANY OTHER PROJECT IN ANY MANNER WITHOUT THE EXPRESS WRITTEN CONSENT OF SAMTEC, INC.</p> <p>DO NOT SCALE DRAWING</p> <p>SHEET SCALE: 1:0.666667</p>	<p>520 PARK EAST BLVD, NEW ALBANY, IN 47150 PHONE: 812-944-6733 FAX: 812-948-5047 e-Mail info@SAMTEC.com code 55322</p>	
	<p>DESCRIPTION: 50 OHM, SMA STRAIGHT JACK REVERSE POLARITY BULKHEAD, RG178</p>	
	<p>DWG. NO. SMA-J-C-X-ST-BR2</p>	
<p>BY: R MUSSER 01/28/2008</p>		<p>SHEET 2 OF 2</p>