

PRODUCT NUMBER
10127397-33HI400LF

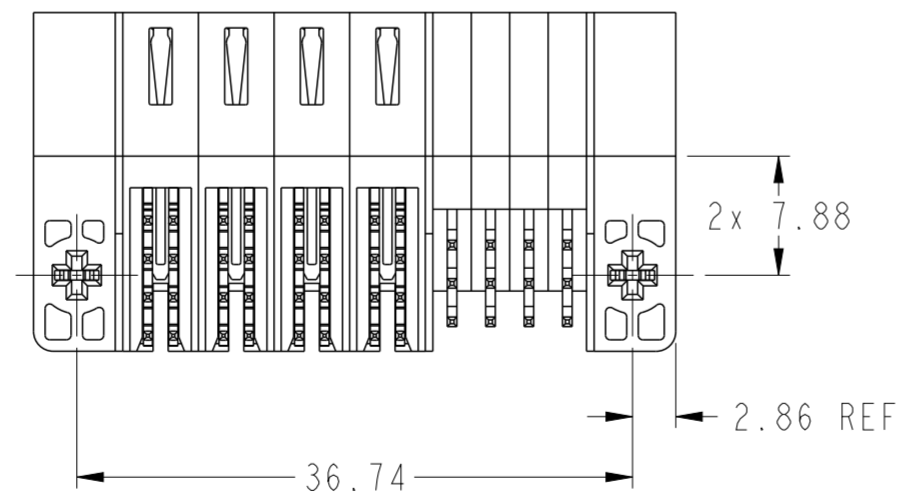
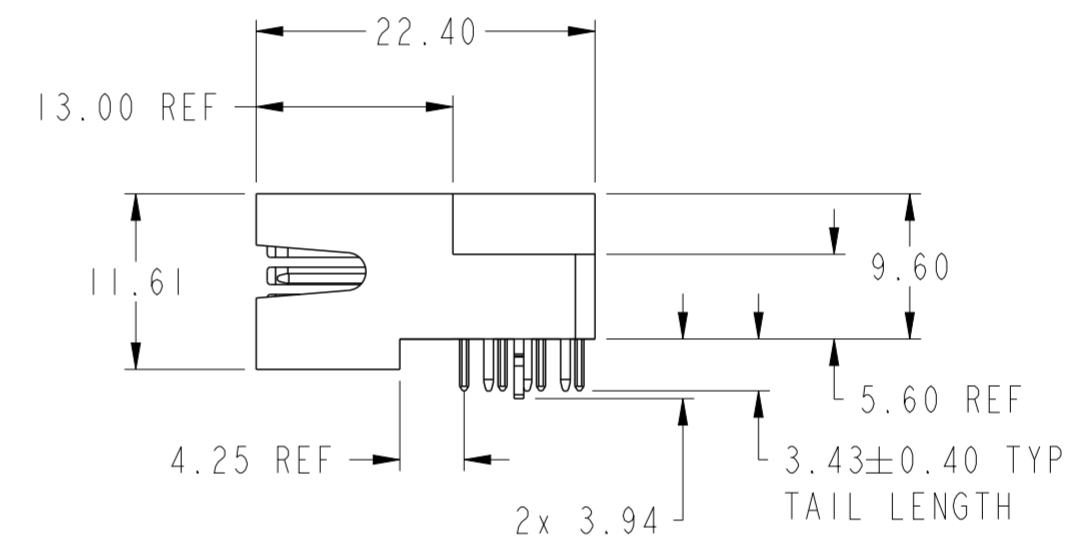
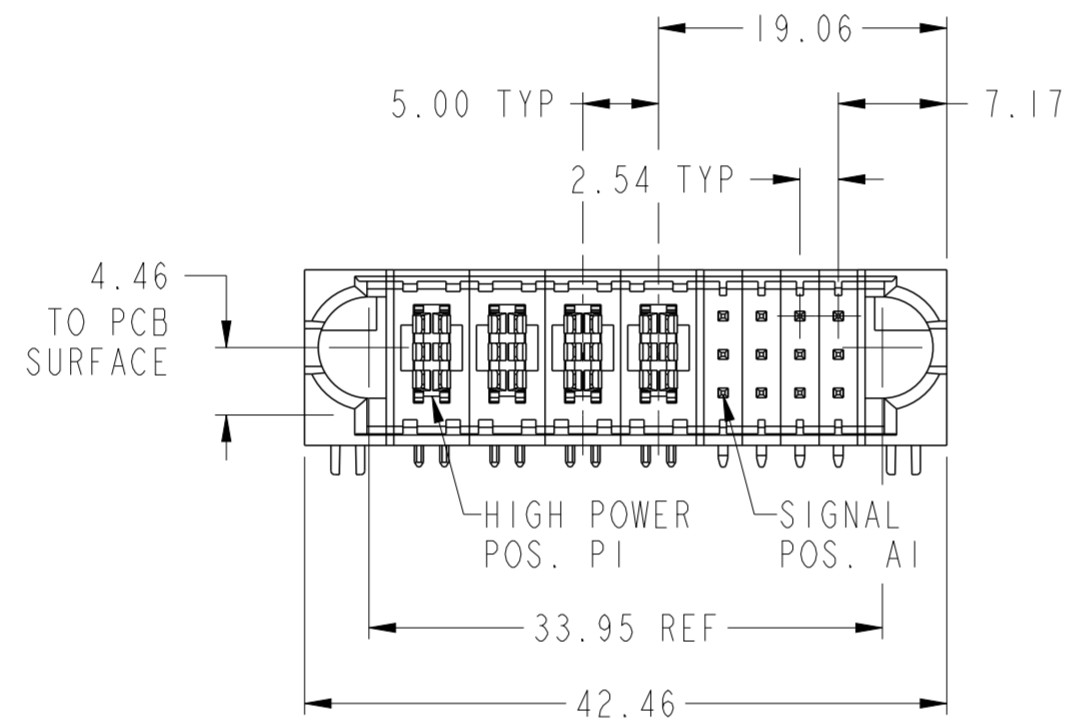
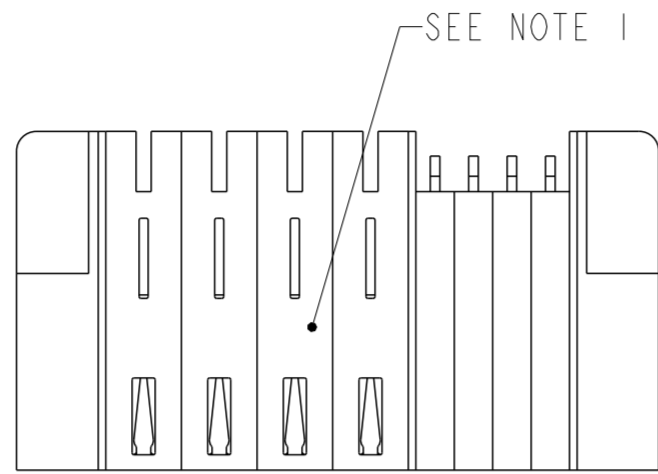

| | | | | | | | | | | | |
|---------------------------------------|---------------------|------|----------------|------------|------------------------|----------------|-----------------|----------|--------------------------|----------------------------|----------|
| spec ref | - | dr | De-Ming Lu | 2016/10/08 | projection | mm | size | A2 | scale | 2:1 | |
| tolerance std | ISO 406 ISO 1101 | eng | De-Ming Lu | 2016/10/14 | | mm | ecn no | - | rel level | Released | |
| TOLERANCES UNLESS OTHERWISE SPECIFIED | | chr | Fancy Zhang | 2016/10/14 | | | | | | | |
| surface | ISO 1302 | appr | Pei-Ming Zheng | 2016/10/14 | product family | PwrBlade ULTRA | rel level | Released | cat. no. | - | |
| | linear | 0.X | ±0.5 | | title | | 4HP+12S, SOLDER | | R/A PLUG, PwrBlade ULTRA | dwg no 10127397-33HI400 | rev A |
| | | 0.XX | ±0.25 | | Product - Customer Drw | | sheet 1 of 3 | | | | |
| | angular | 0° | ±2° | | Product - Customer Drw | | sheet 1 of 3 | | | | |

Amphenol
FCi

© 2016 AFci

PRODUCT NO.

ROWS

HIGH POWER

S

10127397-33HI400LF

C
B
A

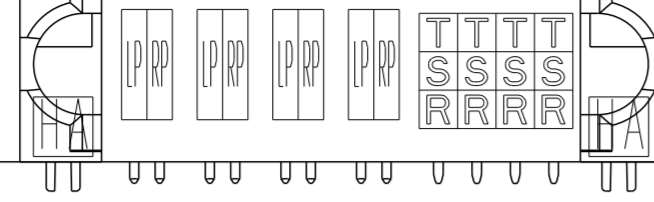

| CODE | DESCRIPTION |
|------|---------------------|
| LP | LEFT POWER CONTACT |
| RP | RIGHT POWER CONTACT |
| R | SIGNAL CONTACT |
| S | SIGNAL CONTACT |
| T | SIGNAL CONTACT |
| HA | HOLD DOWN |

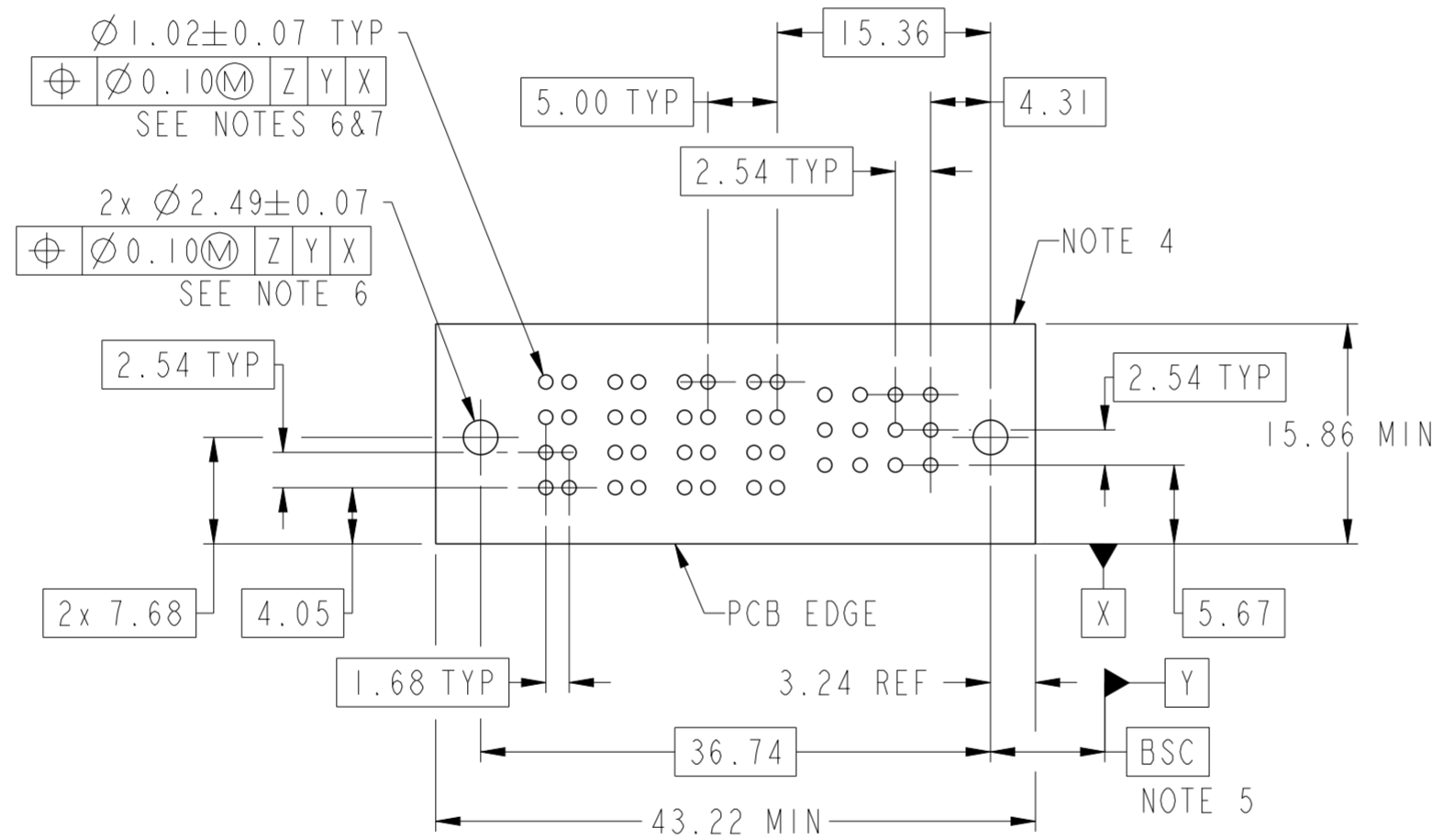

| | | | | | | | | | | | |
|---------------------------------------|--|------------------------|----------------|--------------|---|-----------------|-----------|-----------------------|-----------|-------------|---|
| spec ref | - | dr | De-Ming Lu | 2016/10/08 | projection | mm | size | A2 | scale | 2:1 | |
| tolerance std | ISO 406 ISO 1101 | eng | De-Ming Lu | 2016/10/14 | | mm | ecn no | - | rel level | Released | |
| TOLERANCES UNLESS OTHERWISE SPECIFIED | | chr | Fancy Zhang | 2016/10/14 | | | | | | | |
| surface | ISO 1302 | appr | Pai-Ming Zheng | 2016/10/14 | product family | PwrBlade ULTRA | rel level | Released | cat. no. | - | |
| linear | 0.X ±0.5 0.XX ±0.25 0.XXX ±0.130 | Amphenol FCi | title | | 4HP+12S, SOLDER R/A PLUG, PwrBlade ULTRA | | div no | 10127397-33HI400 | | rev | A |
| angular | 0° ±2° | Product - Customer Drw | | sheet 2 of 3 | | STATUS:Released | | Printed: Oct 14, 2016 | | PDS: Rev :A | |

PRODUCT NUMBER
10127397-33HI400LF

NOTES:

- ①. PRODUCT MARK:
PART NUMBER AND DATE CODE TO BE MARKED ON THIS SURFACE.
THE MARK CAN BE OMITTED IF THERE IS NOT ENOUGH SPACE ON THIS SURFACE.
2. MATERIALS:
HOUSING: HIGH TEMP THERMOPLASTIC WITH GLASS FIBER, UL94V-0, BLACK.
POWER CONTACTS: HIGH CONDUCTIVITY COPPER ALLOY.
SIGNAL CONTACTS: COPPER ALLOY.
HOLD DOWN: COPPER ALLOY.
3. PLATING SPECIFICATION: AFCI 10135186.
- ④. DENOTES CONNECTOR KEEP OUT ZONE.
- ⑤. DATUM AND BASIC DIMENSION ARE ESTABLISHED BY CUSTOMER.
- ⑥. ALL HOLE DIAMETERS ARE FINISHED HOLE SIZES.
- ⑦. 1.150±0.025mm DRILLED HOLE PLATED WITH 7.62µm MIN Sn OVER
25.4µm-76.2µm Cu PLATING TO ACHIEVE A 1.02±0.07mm FINISHED HOLE.
8. THE HOUSING WILL WITHSTAND EXPOSURE TO 265°C PEAK TEMPERATURE FOR 10 SECONDS
IN A WAVE SOLDER APPLICATION.
9. THIS PRODUCT MEETS EUROPEAN UNION DIRECTIVES AND OTHER COUNTRY REGULATIONS
AS DESCRIBED IN AFCI GS-47-0004.
10. PRODUCT SPECIFICATION: AFCI GS-12-1176.
APPLICATION SPECIFICATION: AFCI GS-20-0389.
PRODUCT PACKAGE SPECIFICATION: AFCI GS-14-2354.

Amphenol
FCI

© 2016 AFCI

| | | | | | | | | | | | | |
|---------------|---------------------------------------|-------|--------|------------------------|--------------------------|------------|--------------|-----------------|----------------------------|----------------|-----------|----------|
| spec ref | - | | | dr | De-Ming Lu | 2016/10/08 | projection | mm | size | A2 | scale | 2:1 |
| tolerance std | TOLERANCES UNLESS OTHERWISE SPECIFIED | | | eng | De-Ming Lu | 2016/10/14 | | | ecn no | | | |
| ISO 406 | | | | chr | Fancy Zhang | 2016/10/14 | | | - | | | |
| ISO 1101 | | | | appr | Pai-Ming Zheng | 2016/10/14 | | | product family | PwrBlade ULTRA | rel level | Released |
| surface | linear | 0.X | ±0.5 | | title | | | 4HP+12S, SOLDER | div no 10127397-33HI400 | rev | | |
| ISO 1302 | | 0.XX | ±0.25 | | R/A PLUG, PwrBlade ULTRA | | | A | | | | |
| | | 0.XXX | ±0.130 | | cat. no. | | | | | | | |
| | angular | 0° | ±2° | Product - Customer Drw | | | sheet 3 of 3 | | | | | |

PDS: Rev :A

STATUS:Released

Printed: Oct 14, 2016