

Overview

KEMET's PEH534 is a long-life electrolytic capacitor designed to offer high ripple current capability and low mounting cost. Low ESR is the result of a very low resistive paper/electrolyte system. Low ESR, together with the TDC thermal concept, gives the PEH534 a high ripple current capability.

Applications

Typical applications for KEMET's PEH534 capacitor include switch mode power supplies (SMPS), drives, welding equipment, uninterruptible power supplies (UPS), and other power electronic applications where high current ratings and compact size are important.

Benefits

- Snap-In
- 3,000 hours at +105°C (V_R , I_R applied)
- PCB mounting
- Low ESR and ESL
- High ripple current



Part Number System

PEH534	J	BC	456	0	M	2
Series	Rated Voltage (VDC)	Size Code	Capacitance Code (μF)	Version	Capacitance Tolerance	Termination
Snap-In type Aluminum Electrolytic	J = 35 M = 63 P = 100 R = 200 S = 250 U = 350 V = 400 Y = 450	See Dimension Table	The last two digits represent significant figures. The first digit indicates the total number digits.	0 = Standard	M = $\pm 20\%$	See Termination Table

Performance Characteristics

Item	Performance Characteristics		
Capacitance Range	150 – 22,000 μ F		
Rated Voltage	35 – 450 VDC		
Operating Temperature	-40 to +105°C		
Capacitance Tolerance	\pm 20% at 100 Hz/+20°C		
Operational Lifetime	D (mm)	Rated Voltage and Ripple Current at +105°C (hours)	Rated Voltage at +105°C (hours)
	22 – 40	3,000	4,000
Shelf Life	4 years at +40°C 0 VDC		
Leakage Current	I = 0.003 CV (μ A)		
	C = rated capacitance (μ F), V = rated voltage (VDC). Voltage applied for 5 minutes at +20°C.		
Vibration Test Specifications	Procedure	Requirements	
	0.75 mm displacement amplitude or 10 g maximum acceleration. Vibration applied for three 2-hour sessions at 10 – 500 Hz (Capacitor clamped by body).	No leakage of electrolyte or other visible damage. Deviations in capacitance from initial measurements must not exceed: Δ C/C < 5%	
Standards	IEC 60384-4 long life grade 40/105/56, in accordance with CECC 30 301-809		

Test Method & Performance

Endurance Life Test		
Conditions	Performance	
Temperature	+105°C	
Test Duration	2,000 hours	
Ripple Current	Maximum ripple current specified in table	
Voltage	The sum of DC voltage and the peak AC voltage must not exceed the rated voltage of the capacitor	
Performance	The following specifications will be satisfied when the capacitor is tested at +20°C:	
Capacitance Change	\leq 160 V	Within 15% of the initial value
	$>$ 160 V	Within 10% of the initial value
Equivalent Series Resistance	Does not exceed 200% of the initial value	
Leakage Current	Does not exceed leakage current limit	

Dimensions – Millimeters

D X L	Size Code	Dimensions in mm		Approximate Weight Grams
		D1	L1	
		±0.5	±1.0	
25 x 30	BC	25.5	31	21
25 x 35	BD	25.5	36	24
25 x 40	BE	25.5	41	27
25 x 45	BF	25.5	46	30
25 x 50	BG	25.5	51	33
30 x 25	CB	30.5	26	24
30 x 30	CC	30.5	31	29
30 x 35	CD	30.5	36	34
30 x 40	CE	30.5	41	39
30 x 45	CF	30.5	46	45
30 x 50	CG	30.5	51	51
35 x 25	DB	35.5	26	32
35 x 30	DC	35.5	31	40
35 x 35	DD	35.5	36	48
35 x 40	DE	35.5	41	56
35 x 45	DF	35.5	46	64
35 x 50	DG	35.5	51	72

Note: Add 0.5 mm to D and 1 mm to L for Slewing

Termination Tables

Termination Code	2	2S	3	4	4S
Diameter (mm)					
25	•	•	•		
30	•	•	•		
35	•	•	•	•	•

Mounting: These capacitors are designed to be mounted by their terminations alone and may be used in any position. Dummy pins on 4-pin decks must be isolated.

Termination Code	Termination Style	LL
		±1
Standard Termination Option		
2	2 Pin	6.3
Other Termination Options		
2S	2 Pin	4.0
3	3 Pin	4.0
4	4 Pin	6.3
4S	4 Pin	4.0

Dimensions in mm

Style 2/2S

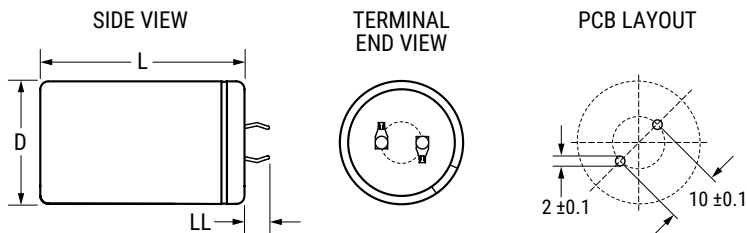

Style 3

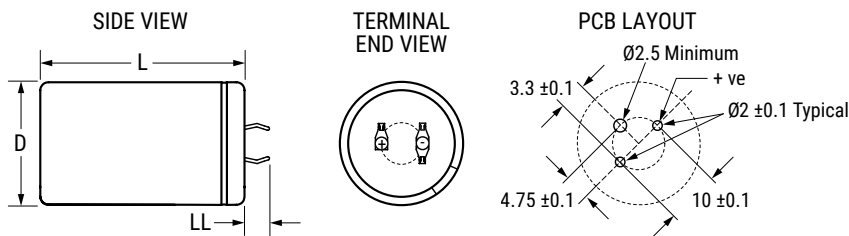

Style 4/4S

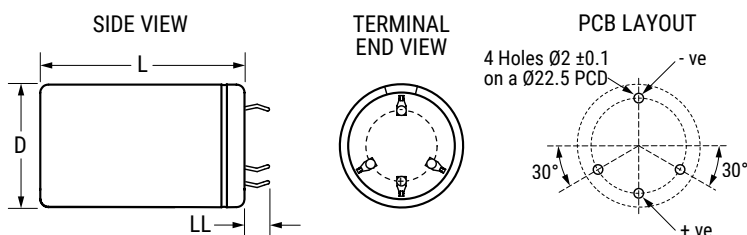

Shelf Life

The capacitance, ESR and impedance of a capacitor will not change significantly after extended storage periods, however the leakage current will very slowly increase. KEMET products are particularly stable and allow a shelf life in excess of three years at 40°C. See sectional specification under each product series for specific data.

Re-age (Reforming) Procedure

Apply the rated voltage to the capacitor at room temperature for a period of one hour, or until the leakage current has fallen to a steady value below the specified limit. During re-aging a maximum charging current of twice the specified leakage current or 5 mA (whichever is greater) is suggested.

Reliability

The reliability of a component can be defined as the probability that it will perform satisfactorily under a given set of conditions for a given length of time.

In practice, it is impossible to predict with absolute certainty how any individual component will perform; thus, we must utilize probability theory. It is also necessary to clearly define the level of stress involved (e.g. operating voltage, ripple current, temperature and time). Finally, the meaning of satisfactory performance must be defined by specifying a set of conditions which determine the end of life of the component.

Reliability as a function of time, $R(t)$, is normally expressed as: $R(t) = e^{-\lambda t}$

where $R(t)$ is the probability that the component will perform satisfactorily for time t , and λ is the failure rate.

Failure Rate

The failure rate is the number of components failing per unit time. The failure rate of most electronic components follows the characteristic pattern:

- Early failures are removed during the manufacturing process.
- The operational life is characterized by a constant failure rate.
- The wear out period is characterized by a rapidly increasing failure rate.

The failures in time (FIT) are given with a 60% confidence level for the various type codes. By convention, FIT is expressed as 1×10^{-9} failures per hour. Failure rate is also expressed as a percentage of failures per 1,000 hours.

e.g., 100 FIT = 1×10^{-7} failures per hour = 0.01%/1,000 hours

End of Life Definition

Catastrophic Failure: short circuit, open circuit or safety vent operation

Parametric Failure:

- Change in capacitance $> \pm 10\%$
- Leakage current $>$ specified limit
- ESR $> 2 \times$ initial ESR value

MTBF

The mean time between failures (MTBF) is simply the inverse of the failure rate.

$$MTBF = 1/\lambda$$

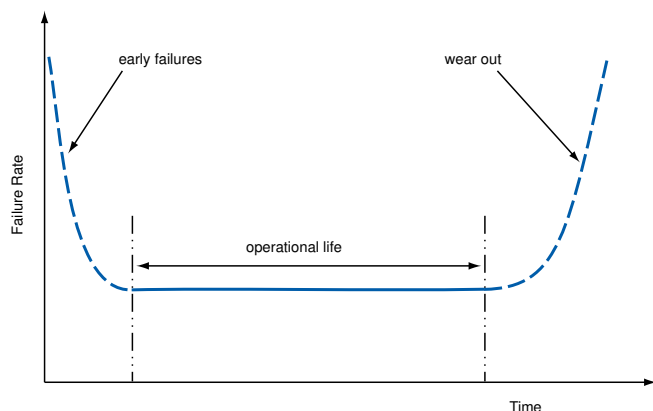

The failure rate is derived from our periodic test results. The failure rate (λ_R) is, therefore, only given at test temperature for life tests. An estimation is also given at 40°C. The expected failure rate for this capacitor range is based on our periodic test results for capacitors with structural similarity. Failure rate is frequently quoted in FIT (Failures In Time) where 1 FIT = 1×10^{-9} failures per hour. Failure rate per hour includes both catastrophic and parametric failures.

Environmental Compliance



All Part Numbers in this datasheet are Reach and RoHS compliant.

As an environmentally conscious company, KEMET is working continuously with improvements concerning the environmental effects of both our capacitors and their production.

In Europe (RoHS Directive) and in some other geographical areas such as China, legislation has been put in place to prevent the use of some hazardous materials, such as lead (Pb), in electronic equipment. All products in this catalog are produced to help our customers' obligations to guarantee their products and fulfill these legislative requirements. The only material of concern in our products has been lead (Pb), which has been removed from all designs to fulfill the requirement of containing less than 0.1% of lead in any homogeneous material. KEMET will closely follow any changes in legislation worldwide and make any necessary changes in its products, whenever needed.

Some customer segments such as medical, military and automotive electronics may still require the use of lead in electrode coatings. To clarify the situation and distinguish products from each other, a special symbol is used on the packaging labels for RoHS compatible capacitors.

Due to customer requirements, there may appear additional markings such as lead-free (LF), or lead-free wires (LFW) on the label.

Table 1 – Ratings & Part Number Reference

VDC	Rated Capacitance	Size Code	Case Size	Ripple Current Maximum		ESR Maximum		Part Number
	100 Hz 20°C (µF)		D x L (mm)	100 Hz 105°C (A)	20 kHz 40°C (A)	100 Hz 20°C (mΩ)	100 kHz 20°C (mΩ)	
35	5600	BC	25 x 30	2.3	7.6	54	43	PEH534JBC4560M(1)
35	6800	BD	25 x 35	2.7	9.0	43	34	PEH534JBD4680M(1)
35	6800	CB	30 x 25	2.9	9.8	40	31	PEH534JCB4680M(1)
35	8200	BE	25 x 40	3.1	10.2	36	28	PEH534JBE4820M(1)
35	8200	CC	30 x 30	3.5	12.1	31	23	PEH534JCC4820M(1)
35	8200	DB	35 x 25	3.1	10.0	37	29	PEH534JDB4820M(1)
35	10000	BF	25 x 45	3.5	11.3	31	24	PEH534JBF5100M(1)
35	10000	CD	30 x 35	4.1	14.3	25	18	PEH534JCD5100M(1)
35	15000	CF	30 x 45	5.3	17.8	17	13	PEH534JCF5150M(1)
35	15000	DD	35 x 35	4.5	14.4	21	17	PEH534JDD5150M(1)
35	22000	DG	35 x 50	6.2	20.1	14	11	PEH534JDG5220M(1)
63	2200	BC	25 x 30	1.9	6.9	92	43	PEH534MBC4220M(1)
63	3300	BE	25 x 40	2.5	9.3	61	34	PEH534MBE4330M(1)
63	3300	CC	30 x 30	2.7	10.6	56	31	PEH534MCC4330M(1)
63	4700	CE	30 x 40	3.6	14.0	39	28	PEH534MCE4470M(1)
63	4700	DC	35 x 30	3.1	11.2	44	23	PEH534MDC4470M(1)
63	5600	CF	30 x 45	4.0	15.6	33	29	PEH534MCF4560M(1)
63	5600	DD	35 x 35	3.7	13.3	36	24	PEH534MDD4560M(1)
63	6800	CG	30 x 50	4.5	17.1	28	18	PEH534MCG4680M(1)
63	6800	DE	35 x 40	4.2	15.2	30	13	PEH534MDE4680M(1)
63	8200	DF	35 x 45	4.7	16.8	26	17	PEH534MDF4820M(1)
63	10000	DG	35 x 50	5.2	18.4	22	11	PEH534MDG5100M(1)
100	1500	BE	25 x 40	1.9	7.0	140	110	PEH534PBE4150M(1)
100	1500	CC	30 x 30	2.0	7.4	130	100	PEH534PCC4150M(1)
100	2200	CE	30 x 40	2.6	9.8	91	70	PEH534PCE4220M(1)
100	2200	DC	35 x 30	2.4	8.8	96	75	PEH534PDC4220M(1)
100	3300	CG	30 x 50	3.3	12.4	62	48	PEH534PCG4330M(1)
100	3300	DE	35 x 40	3.3	11.7	64	50	PEH534PDE4330M(1)
100	3900	DF	35 x 45	3.6	13.1	54	43	PEH534PDF4390M(1)
100	4700	DG	35 x 50	4.1	14.5	46	36	PEH534PDG4470M(1)
200	470	BD	25 x 35	1.1	7.1	290	160	PEH534RBD3470M(1)
200	560	BE	25 x 40	1.3	8.0	250	130	PEH534RBE3560M(1)
200	560	CC	30 x 30	1.3	8.9	240	130	PEH534RCC3560M(1)
200	680	BF	25 x 45	1.4	8.9	200	110	PEH534RBF3680M(1)
200	680	CD	30 x 35	1.5	10.4	200	100	PEH534RCD3680M(1)
200	680	DC	35 x 30	1.5	9.8	200	110	PEH534RDC3680M(1)
200	820	CE	30 x 40	1.7	11.8	160	87	PEH534RCE3820M(1)
200	820	DC	35 x 30	1.6	9.8	170	93	PEH534RDC3820M(1)
200	1000	CG	30 x 50	2.0	13.9	130	71	PEH534RCG4100M(1)
200	1000	DD	35 x 35	1.9	11.6	140	75	PEH534RDD4100M(1)
200	1500	DF	35 x 45	2.5	14.7	93	51	PEH534RDF4150M(1)
250	390	BE	25 x 40	1.1	7.9	290	140	PEH534SBE3390M(1)
250	390	CC	30 x 30	1.1	8.7	280	140	PEH534SCC3390M(1)
250	470	BF	25 x 45	1.3	8.8	240	120	PEH534SBF3470M(1)
250	470	CD	30 x 35	1.3	10.1	240	110	PEH534SCD3470M(1)
250	470	DC	35 x 30	1.3	9.6	240	120	PEH534SDC3470M(1)
250	560	BG	25 x 50	1.4	9.6	200	100	PEH534SBG3560M(1)
250	560	CE	30 x 40	1.5	11.4	200	95	PEH534SCE3560M(1)
250	680	CF	30 x 45	1.7	12.8	160	79	PEH534SCF3680M(1)
250	680	DD	35 x 35	1.7	11.5	170	83	PEH534SDD3680M(1)
250	820	CG	30 x 50	1.9	14.2	140	66	PEH534SCG3820M(1)
250	820	DE	35 x 40	1.9	13.1	140	69	PEH534SDE3820M(1)
250	1000	DF	35 x 45	2.2	14.6	110	57	PEH534SDF4100M(1)
350	220	BE	25 x 40	0.9	5.8	560	350	PEH534UBE3220M(1)
350	220	CC	30 x 30	0.9	6.0	550	340	PEH534UCC3220M(1)
350	220	DB	35 x 25	0.9	5.8	560	350	PEH534UDB3220M(1)
350	330	CE	30 x 40	1.2	8.0	370	230	PEH534UCE3330M(1)
350	330	DC	35 x 30	1.2	7.4	370	230	PEH534UDC3330M(1)
350	390	CF	30 x 45	1.4	9.0	310	190	PEH534UCF3390M(1)
350	390	DD	35 x 35	1.4	8.6	320	200	PEH534UDD3390M(1)
VDC	Rated Capacitance	Size Code	Case Size	Ripple Current		ESR		Part Number

(1) Termination code: See Termination Tables for available options.

Table 1 – Ratings & Part Number Reference cont.

VDC	Rated Capacitance	Size Code	Case Size	Ripple Current Maximum		ESR Maximum		Part Number
	100 Hz 20°C (µF)		D x L (mm)	100 Hz 105°C (A)	20 kHz 40°C (A)	100 Hz 20°C (mΩ)	100 kHz 20°C (mΩ)	
350	470	DE	35 x 40	1.6	9.7	260	160	PEH534UDE3470M(1)
350	560	DF	35 x 45	1.8	10.9	220	140	PEH534UDF3560M(1)
400	150	BD	25 x 35	0.8	5.1	680	410	PEH534VBD3150M(1)
400	150	CB	30 x 25	0.8	5.2	680	400	PEH534VCB3150M(1)
400	220	BF	25 x 45	1.0	6.5	470	280	PEH534VBF3220M(1)
400	220	CD	30 x 35	1.0	7.1	460	270	PEH534VCD3220M(1)
400	220	DC	35 x 30	1.1	7.0	460	280	PEH534VDC3220M(1)
400	330	CF	30 x 45	1.4	9.2	310	180	PEH534VCF3330M(1)
400	330	DD	35 x 35	1.4	8.7	310	190	PEH534VDD3330M(1)
400	390	CG	30 x 50	1.5	10.2	260	160	PEH534VCG3390M(1)
400	390	DE	35 x 40	1.5	9.8	260	160	PEH534VDE3390M(1)
400	470	DF	35 x 45	1.8	11.1	220	130	PEH534VDF3470M(1)
400	560	DG	35 x 50	2.0	12.3	180	110	PEH534VDG3560M(1)
450	150	BE	25 x 40	0.9	5.8	570	330	PEH534YBE3150M(1)
450	150	CC	30 x 30	0.9	6.1	560	330	PEH534YCC3150M(1)
450	150	DB	35 x 25	0.9	5.9	570	330	PEH534YDB3150M(1)
450	220	CE	30 x 40	1.2	8.1	380	220	PEH534YCE3220M(1)
450	220	DC	35 x 30	1.2	7.5	390	230	PEH534YDC3220M(1)
450	330	CG	30 x 50	1.5	10.3	260	150	PEH534YCG3330M(1)
450	330	DE	35 x 40	1.5	9.9	260	150	PEH534YDE3330M(1)
450	390	DF	35 x 45	1.7	11.3	220	130	PEH534YDF3390M(1)
450	470	DG	35 x 50	1.9	12.4	180	110	PEH534YDG3470M(1)
VDC	Rated Capacitance	Size Code	Case Size	Ripple Current		ESR		Part Number

(1) Termination code: See Termination Tables for available options.

Mechanical Data

The capacitor may be mounted in any position. PEH534 is supplied with an insulation sleeve. Voltage proof of the insulation sleeve = 2.5 kVDC (1 min). The minus pole is marked on the case surface. UL recognized sleeving is available for custom parts in this range, upon request. (UL No. E358957)

Marking

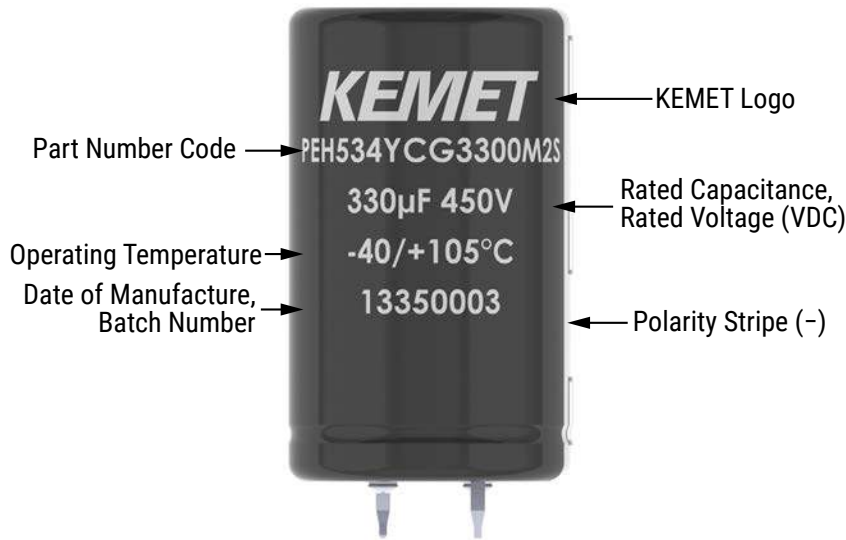

Construction

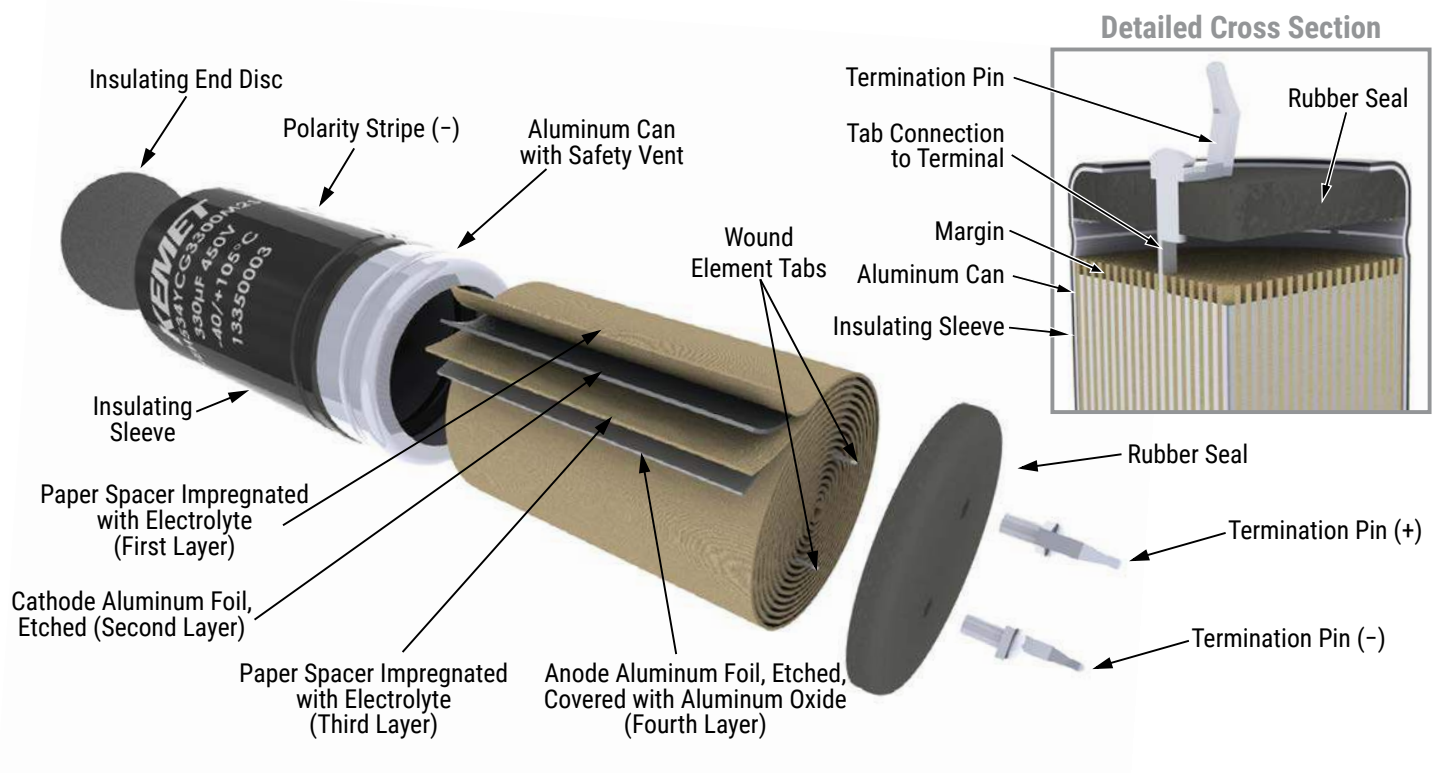

Construction Data

The manufacturing process begins with the anode foil being electrochemically etched to increase the surface area and then “formed” to produce the aluminum oxide layer. Both the anode and cathode foils are then interleaved with absorbent paper and wound into a cylinder. During the winding process, aluminum tabs are attached to each foil to provide the electrical contact.

The deck, complete with terminals, is attached to the tabs and then folded down to rest on top of the winding. The complete winding is impregnated with electrolyte before being housed in a suitable container, usually an aluminum can, and sealed. Throughout the process, all materials inside the housing must be maintained at the highest purity and be compatible with the electrolyte.

Each capacitor is aged and tested before being sleeved and packed. The purpose of aging is to repair any damage in the oxide layer and thus reduce the leakage current to a very low level. Aging is normally carried out at the rated temperature of the capacitor and is accomplished by applying voltage to the device while carefully controlling the supply current. The process may take several hours to complete.

Damage to the oxide layer can occur due to variety of reasons:

- Slitting of the anode foil after forming
- Attaching the tabs to the anode foil
- Minor mechanical damage caused during winding

A sample from each batch is taken by the quality department after completion of the production process.

The following tests are applied and may be varied at the request of the customer. In this case the batch, or special procedure, will determine the course of action.

Electrical:

- Leakage current
- Capacitance
- ESR
- Impedance
- Tan Delta

Mechanical/Visual:

- Overall dimensions
- Torque test of mounting stud
- Print detail
- Box labels
- Packaging, including packed quantity

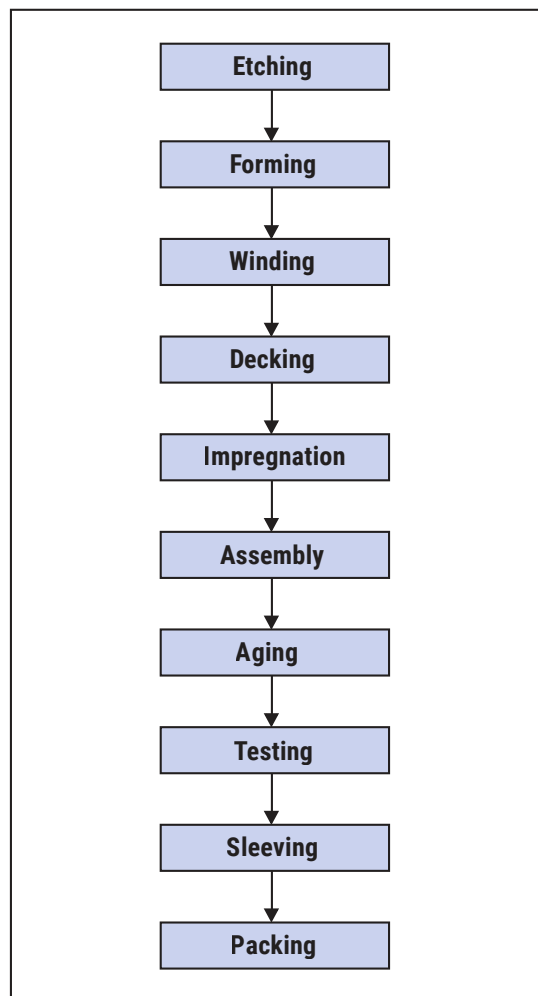
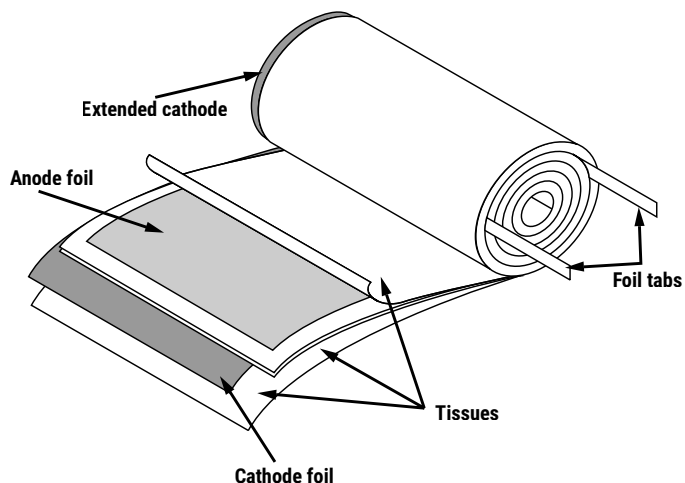

KEMET Electronics Corporation Sales Offices

For a complete list of our global sales offices, please visit www.kemet.com/sales.

Disclaimer

YAGEO Corporation and its affiliates do not recommend the use of commercial, automotive, and/or COTS grade products for high reliability applications or manned space flight.

All product specifications, statements, information and data (collectively, the "Information") in this datasheet are subject to change. The customer is responsible for checking and verifying the extent to which the Information contained in this publication is applicable to an order at the time the order is placed. All Information given herein is believed to be accurate and reliable, but it is presented without guarantee, warranty, or responsibility of any kind, expressed or implied.

Statements of suitability for certain applications are based on KEMET Electronics Corporation's ("KEMET") knowledge of typical operating conditions for such applications, but are not intended to constitute – and KEMET specifically disclaims – any warranty concerning suitability for a specific customer application or use. The Information is intended for use only by customers who have the requisite experience and capability to determine the correct products for their application. Any technical advice inferred from this Information or otherwise provided by KEMET with reference to the use of KEMET's products is given gratis, and KEMET assumes no obligation or liability for the advice given or results obtained.

Although KEMET designs and manufactures its products to the most stringent quality and safety standards, given the current state of the art, isolated component failures may still occur. Accordingly, customer applications which require a high degree of reliability or safety should employ suitable designs or other safeguards (such as installation of protective circuitry or redundancies) in order to ensure that the failure of an electrical component does not result in a risk of personal injury or property damage.

Although all product-related warnings, cautions and notes must be observed, the customer should not assume that all safety measures are indicated or that other measures may not be required.

KEMET requires its products to be packaged and shipped on pallets. This is because KEMET's products are specifically designed to be packed onto pallets during shipment. If for any reason, the products are removed from pallets by the shipping party and shipped to the end customer, then additional external protection is required. In this instance, an external box with two carton layers and an upwards orientation sticker must be used by the shipping party, with the empty space filled with filling material, and afterwards sealing the box. If this packing and packaging guideline is not followed by the shipping party, the shipping party, and not KEMET, will be held responsible for any packaging, packing and/or product damages upon delivery of the products to the end customer. KEMET hereby disclaims any liability for damages to the products or otherwise that have been, or threaten to be, inflicted, result from or are in any way related to the packaging, packing or damage by the shipping party in contravention of the packing and packaging guidelines herein.

KEMET is a registered trademark of KEMET Electronics Corporation.