

PRODUCT PART NUMBER
10151422-XXXXXXLF

0.35±0.05 TYP.

AFCI

MMDDYY

2X 3.00

DIM. D

2X 2.80

DATE CODE & PART NO.
(SEE NOTE 5)

DIM A

1.80±0.05

DIM B

1.00

Ø OF KEY

14.50

11.65±0.10

10.00

#B1

1.80

5.80

(HOUSING HEIGHT)

#A1

0.15±0.10

DIM C±0.10

1.35±0.10

1.65±0.10

Y

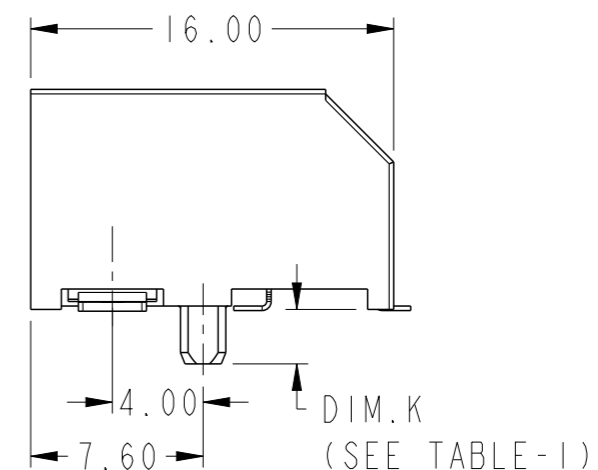
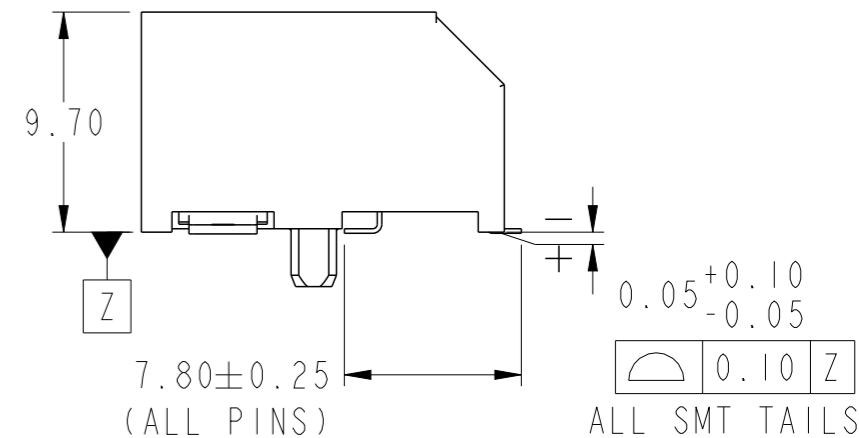

TABLE-1	
POS.	LOCATOR LENGTH - DIM.K
36 & 64 & 98 & 164	10151422-□ □ □ 2 □ □ □ LF 2.40mm

2X Ø 2.00±0.05

spec ref	-	dr	Dipu Joseph	2020/02/03
tolerance std	ASME Y14.5	eng	Lim, Jin-Shyan	2020/07/27
TOLERANCES UNLESS OTHERWISE SPECIFIED		chr	-	-
		appr	Koon-Poh Tay	2020/08/14
surface	linear	0.X	±0.30	Amphenol FCi
		0.XX	±0.20	
		0.XXX	±0.10	
ASME Y14.5	angular	0°	±1°	

projection	MM	size	A3	scale	3:1
		ecn no	ELX-S-37672-1		
product family	-	rel level	Released		
PCI EXPRESS CONN.		dwg no	10151422		rev
R/A SMT, FOR GEN4				B	
cat. no.	-	Product - Customer Drw		sheet 1 of 4	

Amphenol
FCi

© 2016 AFCI

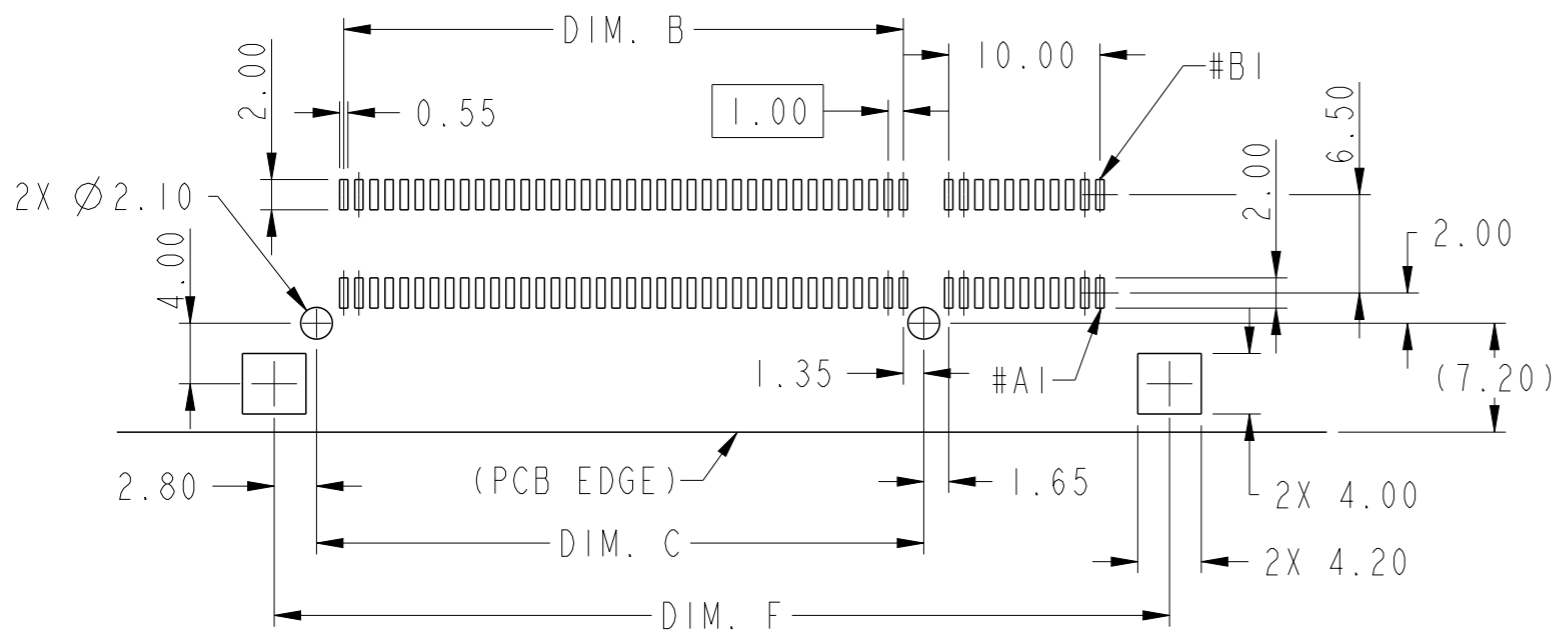

RECOMMENDED PCB LAYOUT - TOP VIEW
(GENERAL TOLERANCES: ±0.05)

CONNECTOR LINK WIDTH	POS	N SPACES	DIM. A	DIM. B	DIM. C	DIM. D	DIM. F	DIM. G	PIN # "L"
X1	36	6	7.65	6.00	9.15	25.00	28.20	8.15	B17
X4	64	20	21.65	20.00	23.15	39.00	42.20	22.15	B31
X8	98	37	38.65	37.00	40.15	56.00	59.20	39.15	B48
X16	164	70	71.65	70.00	73.15	89.00	92.20	72.15	B81

- 1.) NO TIE BAR PERMITTED FROM CARD EDGE TO LEADING EDGE OF PAD FOR PIN #A1 AND PIN # "L".
- 2.) CHAMFER EDGES MUST BE FREE OF CUTTING BURRS.
- 3.) TOLERANCE: ±0.13mm.

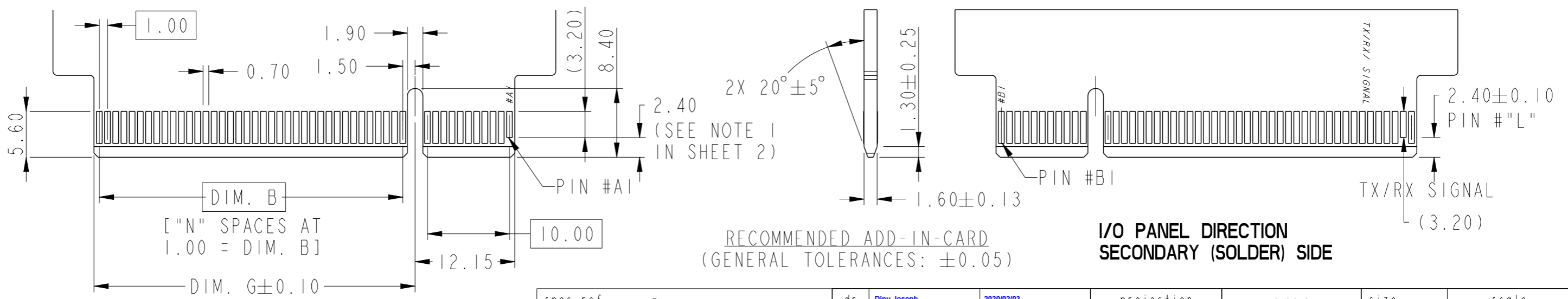

I/O PANEL DIRECTION
SECONDARY (SOLDER) SIDE

RECOMMENDED ADD-IN-CARD
(GENERAL TOLERANCES: ±0.05)

I/O PANEL DIRECTION
SECONDARY (SOLDER) SIDE

spec ref	-	dr	Dipu Joseph	2020/02/03	projection	MM	size	A3	scale	2:1	
tolerance std	ASME Y14.5	eng	Lim, Jin-Shyan	2020/07/27			ecn no	ELX-S-37672-1			
TOLERANCES UNLESS OTHERWISE SPECIFIED		chr	-	apppr			Koon-Poh Tay	2020/08/14	product family	-	rel level
surface	linear	0.X	±0.30		PCI EXPRESS CONN.		dwg no	10151422		rev	B
		0.XX	±0.20		R/A SMT, FOR GEN4						
	angular	0°	±1°		cat. no.	-	Product - Customer Drw	sheet 2 of 4			

NOTES:

1. MATERIAL:

- 1.1) HOUSING: HIGH TEMPERATURE THERMO PLASTIC, LCP COLOR: BLACK, UL94V-0.
- 1.2) CONTACT: COPPER ALLOY.
- 1.3) HOLD DOWN PLATE: COPPER ALLOY.

2. FINISH:

- 2.1) 10151422-XOXXXXX LF:
CONTACT MATING SIDE: 0.127µm [5µ"] MIN. GOLD (Au) OVER ON CONTACT AREA
OVER 1.27µm [50µ"] MIN. TO 2.54µm [100µ"] MAX. NICKEL (Ni) UNDERPLATED.
- 2.2) 10151422-XIXXXXXX LF:
CONTACT MATING SIDE: 0.38µm [15µ"] MIN. GOLD (Au) OVER ON CONTACT AREA
OVER 1.27µm [50µ"] MIN. TO 2.54µm [100µ"] MAX. NICKEL (Ni) UNDERPLATED.
- 2.3) 10151422-X2XXXXX LF:
CONTACT MATING SIDE: 0.76µm [30µ"] MIN. GOLD (Au) OVER ON CONTACT AREA
OVER 1.27µm [50µ"] MIN. TO 2.54µm [100µ"] MAX. NICKEL (Ni) UNDERPLATED.
- 2.4) SOLDER TAIL (ALL):
1.91µm [75µ"] MIN. PURE MATTE TIN (LEAD-FREE) ON SOLDER TAIL OVER
1.27µm [50µ"] MIN. TO 2.54µm [100µ"] MAX. NICKEL (Ni) UNDERPLATED.
- 2.5) HOLD DOWN (SOLDER TAB):
2.54µm [100µ"] MIN. 100% PURE MATTE TIN (Sn) (LEAD-FREE) OVER
1.27µm [50µ"] Min. NICKEL (Ni) UNDERPLATED.

3. PRODUCT SPECIFICATION: GS-12-1406

4. PRODUCT MEETS EUROPEAN UNION DIRECTIVES AND OTHER COUNTRY REGULATIONS AS DESCRIBED IN GS-47-0004.

5. DATE CODE BE PRINTED ON THIS SURFACE.
DATE CODE "MMDDYYL", MMDDYY IS ASSEMBLY DATE.
L IS AFCI PRODUCT SITE.
- "M" IS DENOTES: MALAYSIA.

6. THE HOUSING WILL WITHSTAND EXPOSURE TO 260°C PEAK TEMPERATURE FOR 10 SECONDS IN A CONVECTION, INFRA-RED OR VAPOR PHASE REFLOW OVEN.

7. A SYMBOL $\triangle B$ WILL BE NEXT TO ANY DIMENSION, VIEW OR NOTE WHICH HAS BEEN MODIFIED WITH THE CURRENT DRAWING REVISION.

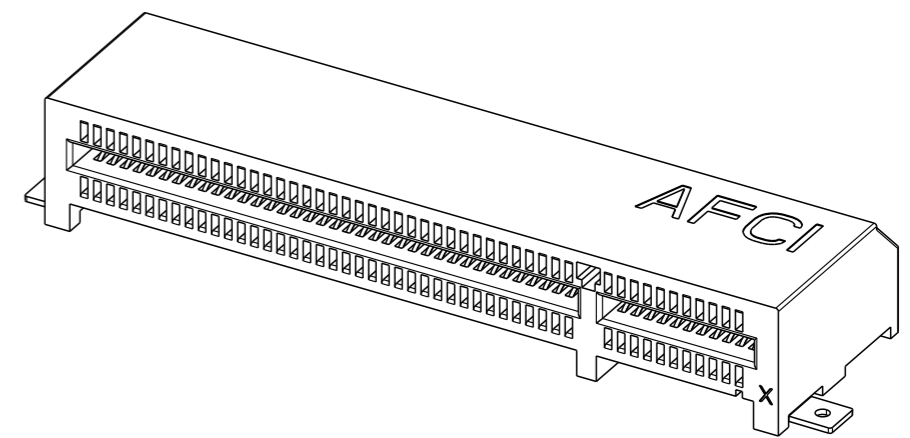

spec ref -		dr	Dipu Joseph	2020/02/03	projection	MM	size	A3	scale	2:1	
tolerance std		eng	Lim, Jin-Shyan	2020/07/27			ecn no		ELX-S-37672-1		
- ASME Y14.5		chr	-	-			rel level		Released		
surface		appr	Koon-Poh Tay	2020/08/14	product family		-		-		
ASME Y14.5				PCI EXPRESS CONN. R/A SMT, FOR GEN4		dwg no 10151422		rev B			
linear	0.X									±0.30	
angular	0°									±1°	
ASME Y14.5		cat. no.		-		Product - Customer Drw		sheet 3 of 4			

1

2

3

4

A

B

C

D

A

B

C

D

PART NUMBER
 10151422-□ □ □ □ □ □ □ LF

HOUSING
 0: LCP BLACK

CONTACT PLATING
 0: 5μ" Au
 1: 15μ" Au
 2: 30μ" Au

NO OF POSITION
 0: 64 POS.
 1: 98 POS.
 2: 164 POS.
 3: 36 POS.

LOCATOR LENGTH
 1: DIM. K=4.40mm
 2: DIM. K=2.40mm

0: NIL

1: TAPE & REEL --- (AVAILABLE FOR 64 & 98 POS.)
 2: HARD TRAY ----- (AVAILABLE FOR 164 POS.)
 3: SOFT TRAY ----- (NOT AVAILABLE)

1: 5.80mm Z-H† 

Amphenol
FCi

© 2016 APCI

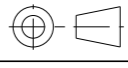
spec ref	-	dr	Dipu Joseph	2020/02/03	projection		MM	size	A3	scale	1:1
tolerance std	ASME Y14.5	eng	Lim, Jin-Shyan	2020/07/27	chr	-		ecn no	ELX-S-37672-1	rel level	Released
surface	ASME Y14.5	appr	Koon-Poh Tay	2020/08/14	product family	-		rel level	Released		
		linear	0.X	±0.30	Amphenol FCi	PCI EXPRESS CONN. R/A SMT, FOR GEN4	cat. no.	-	Product - Customer Drw	sheet 4 of 4	rev B
			0.XX	±0.20							
		angular	0°	±1°							