

REV.	DATE	ECR NO.	DESCRIPTION
NC	03/11/10	XXXXXX	INITIAL RELEASE

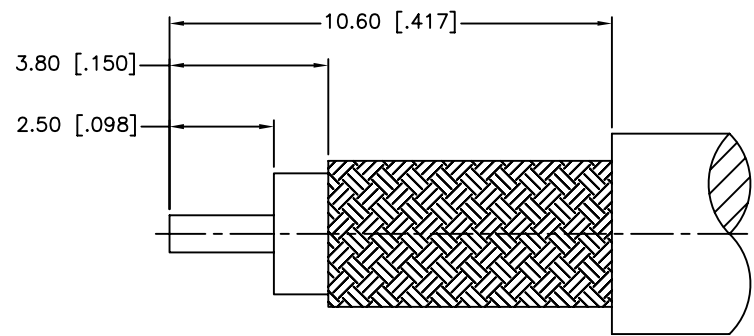

RECOMMENDED
CABLE STRIPPING DIM'S

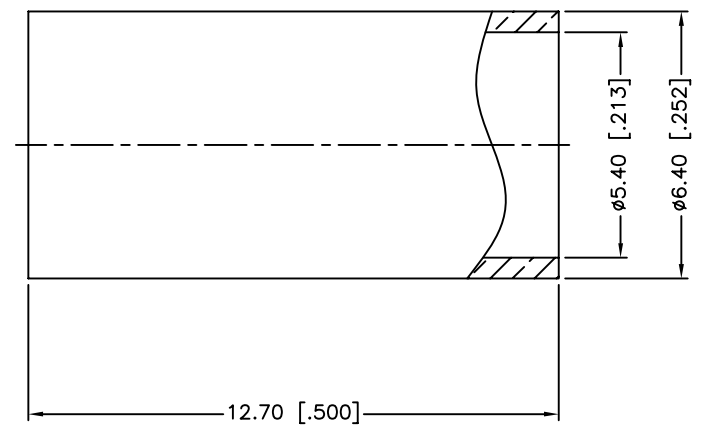
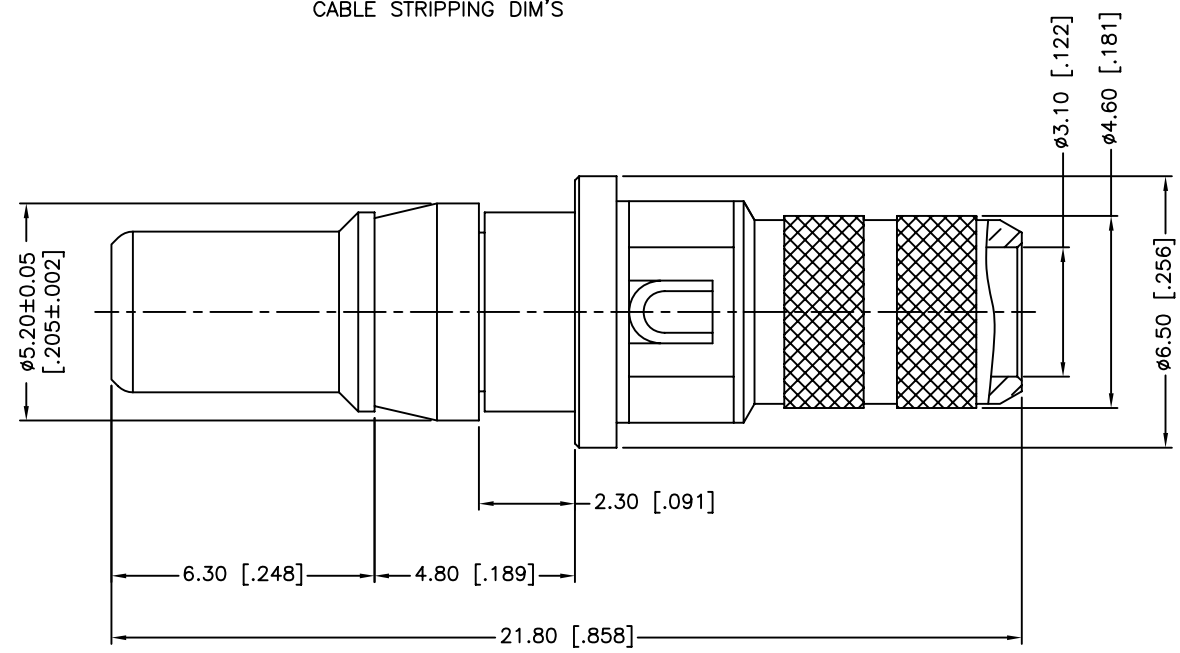

1. CRIMPED FERRULE
HEX CRIMP SIZE .213"
2. CONTACT PIN TO SOLDER

5	FERRULE	BRASS	GOLD	1
4	RETAINER RING	BERTLLIUM COPPER	NICKEL	1
3	CONTACT PIN	PHOSPHOR BRONZE	GOLD	1
2	INSULATOR	PTFE	NATURAL	1
1	BODY	BRASS	GOLD	1
DESCRIPTION	MATERIAL	FINISH	QTY	

UNLESS OTHERWISE SPECIFIED DIMENSIONS ARE IN MILLIMETERS. DIMENSIONS IN [] ARE IN INCHES AND FOR CUSTOMER REFERENCE ONLY.

UNLESS OTHERWISE SPECIFIED TOLERANCES FOR MILLIMETERS ARE:
0.5 - 8mm ± 0.20mm
8 - 30mm ± 0.40mm
30 - 120mm ± 0.50mm

UNLESS OTHERWISE SPECIFIED TOLERANCES FOR INCHES ARE:
.020 - .315 = ± 0.007"
.315 - 1.180 = ± 0.015"
1.180 - 4.724 = ± 0.020"

DO NOT SCALE DRAWING

APPROVALS	DATE
DRAWN M.ZHANG	03/11/10
CHECKED	
ISSUED	
SHEET 1 OF 1	
CAD FILE	C:/CONNEX/212106.DWG

Amphenol Connex

PART DESCRIPTION
**D-SUB CRIMP PLUG
(FOR RG-58/U,58C/U)**

PART NO.
212106

DWG. NO. 212106.DWG	REV. B	SIZE A	SCALE NA
---------------------	--------	--------	----------