

THIS DRAWING IS UNPUBLISHED. RELEASED FOR PUBLICATION
 © COPYRIGHT - BY - ALL RIGHTS RESERVED.

LOC	DIST	REVISIONS					
		P	LTR	DESCRIPTION	DATE	DWN	APVD
-	-		B	REV PER ECO 13-001557	2-12-13	CT	DM
			C	REVISED PER ECO-15-013009	03DEC15	RS	CT

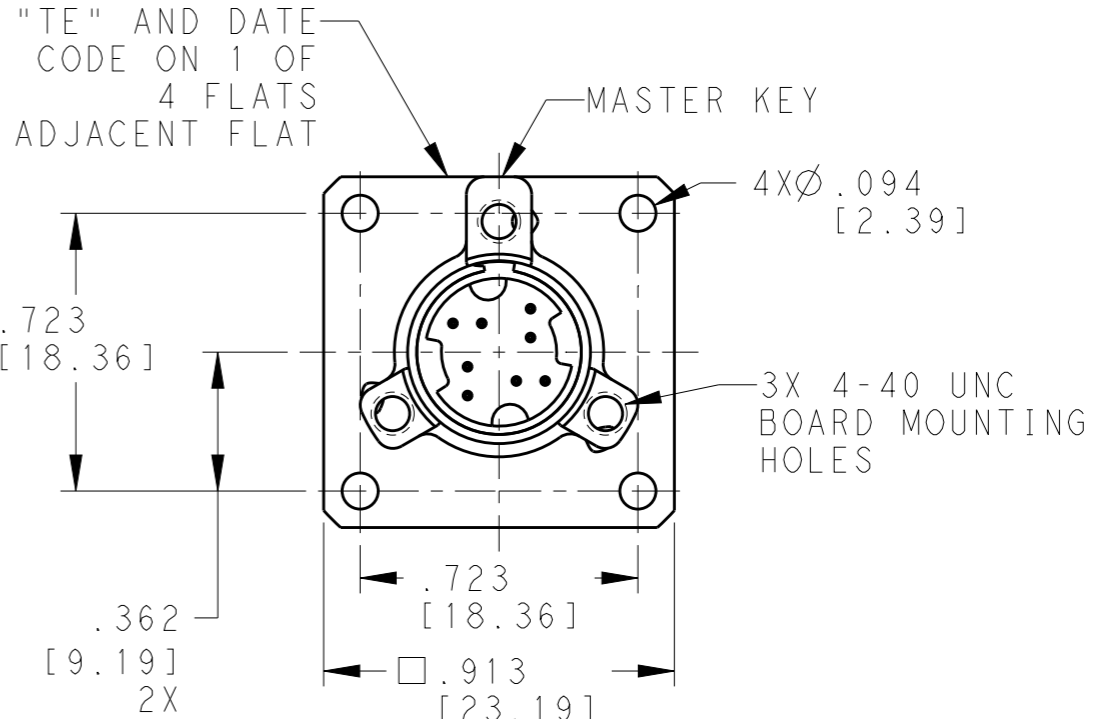

RECEPTACLE: QTY 1
 MATERIAL: ALUMINUM
 FINISH: SEE TABLE

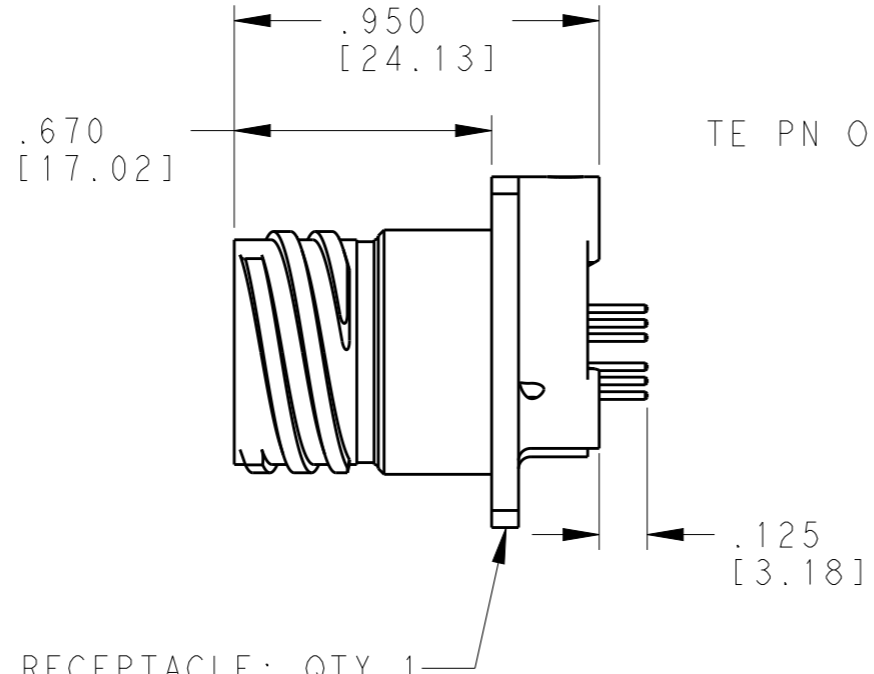
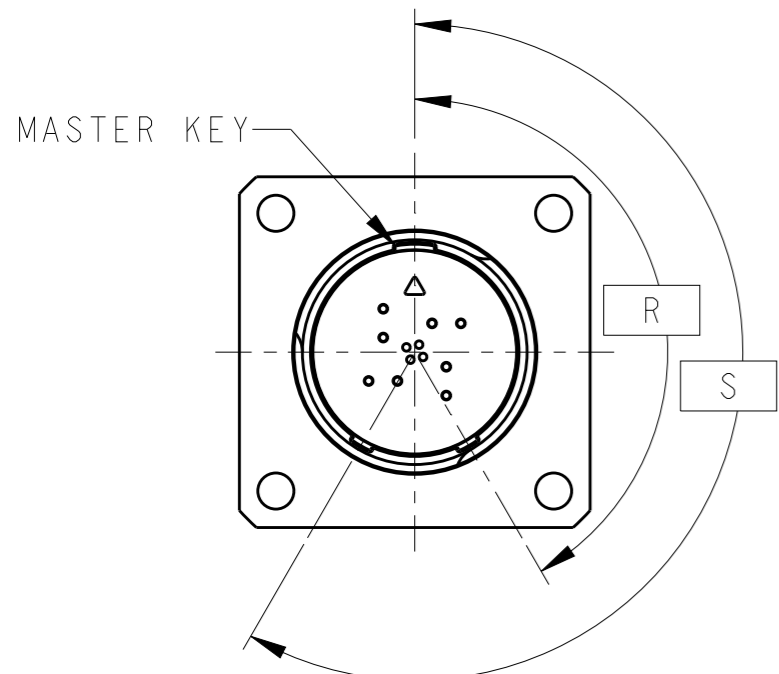
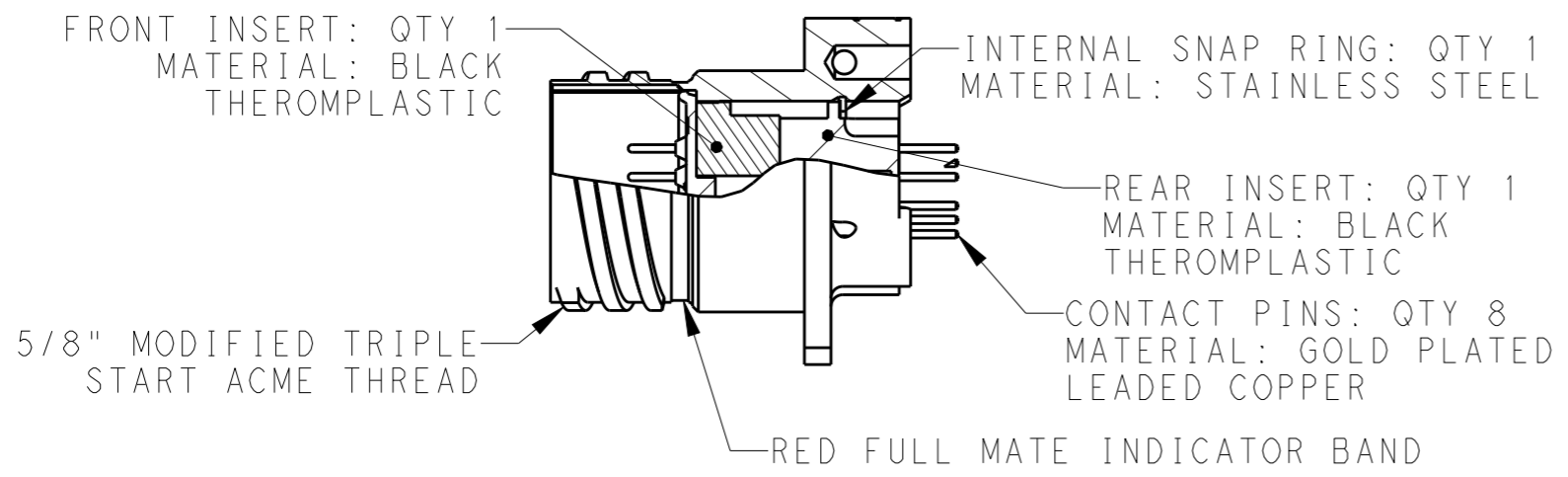
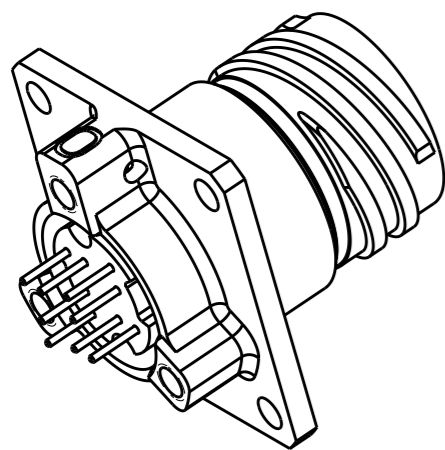

B	BLACK ZINC NICKEL PLATE	2102453-6
B	NICKEL PLATE	2102453-5
A	BLACK ZINC NICKEL PLATE	2102453-4
A	NICKEL PLATE	2102453-3
NORMAL	BLACK ZINC NICKEL PLATE	2102453-2
NORMAL	NICKEL PLATE	2102453-1
KEYING OPTION	FINISH	PART NUMBER

KEY OPTION	KEY ROTATION	
	"R"	"S"
NORMAL	150°	210°
A	140°	215°
B	132°	248°

THIS DRAWING IS A CONTROLLED DOCUMENT. DIMENSIONING AND TOLERANCING PER ASME Y14.5M (ISO STANDARDS)

DIMENSIONS: INCHES [mm]	TOLERANCES UNLESS OTHERWISE SPECIFIED: 0 PLC ±- 1 PLC ±- 2 PLC ±- 3 PLC ±.005 [0.13] 4 PLC ±- ANGLES ±-	MATERIAL -	FINISH -	DWN 18AUG2011 MCKIBBEN, JOHN	CHK 18AUG2011 DOWHOWER, KENNETH	APVD 18AUG2011 DOWHOWER, KENNETH	PRODUCT SPEC 108-2482	APPLICATION SPEC 114-32025	WEIGHT -	CUSTOMER DRAWING	SCALE 2:1	SHEET 1 OF 2	REV C
----------------------------	---	------------	----------	---------------------------------	------------------------------------	-------------------------------------	--------------------------	-------------------------------	----------	------------------	-----------	--------------	-------

NAME: PCB SQUARE FLANGE RECEPTACLE MOUNT ASSEMBLY

SIZE A3	CAGE CODE 00779	DRAWING NO. C-2102453	RESTRICTED TO -
---------	-----------------	-----------------------	-----------------

TE Connectivity

THIS DRAWING IS UNPUBLISHED.

RELEASED FOR PUBLICATION

© COPYRIGHT - BY - ALL RIGHTS RESERVED.

LOC		DIST		REVISIONS				
P	LTR	DESCRIPTION	DATE	DWN	APVD			
-	-	SEE SHEET 1	-	-	-			

RECOMMENDED BOARD LAYOUT

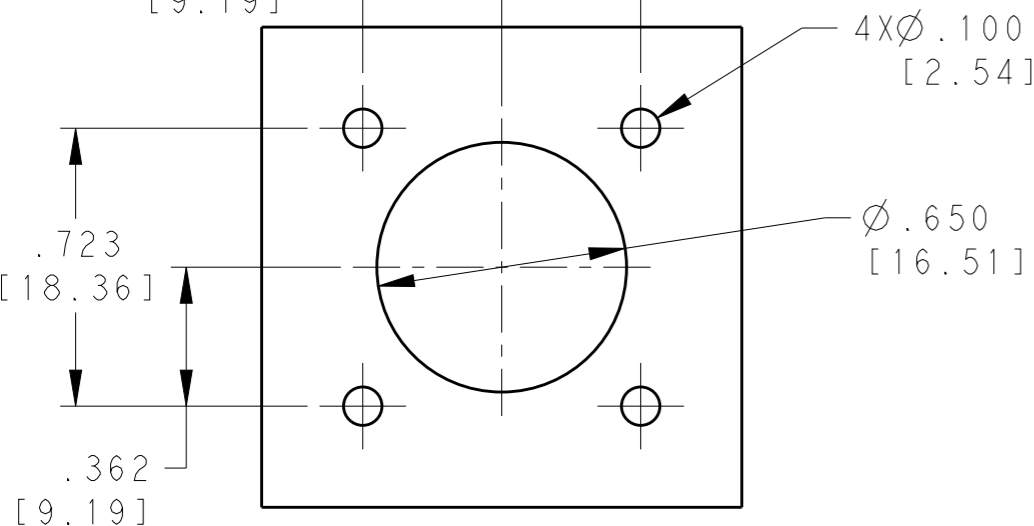
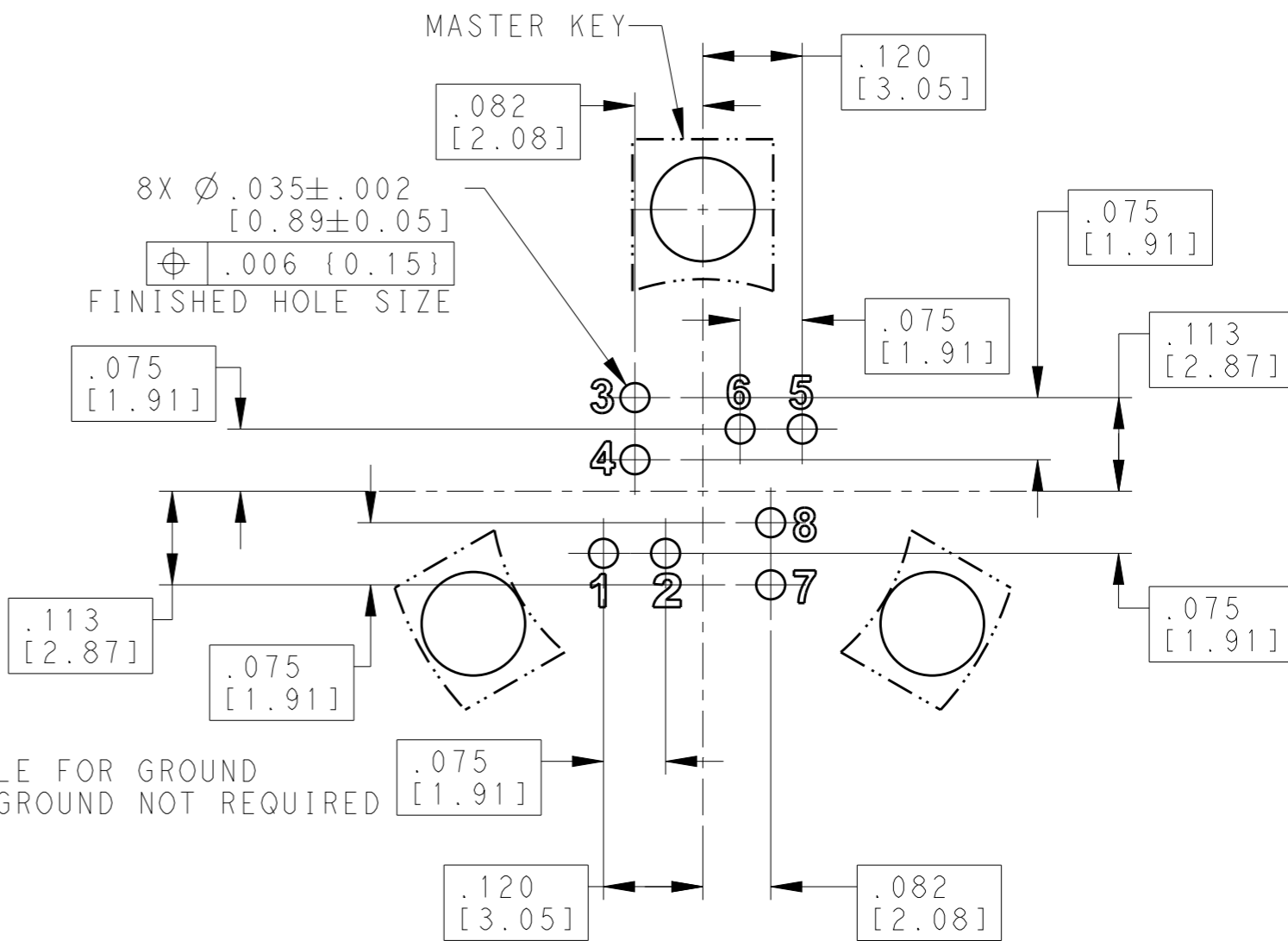
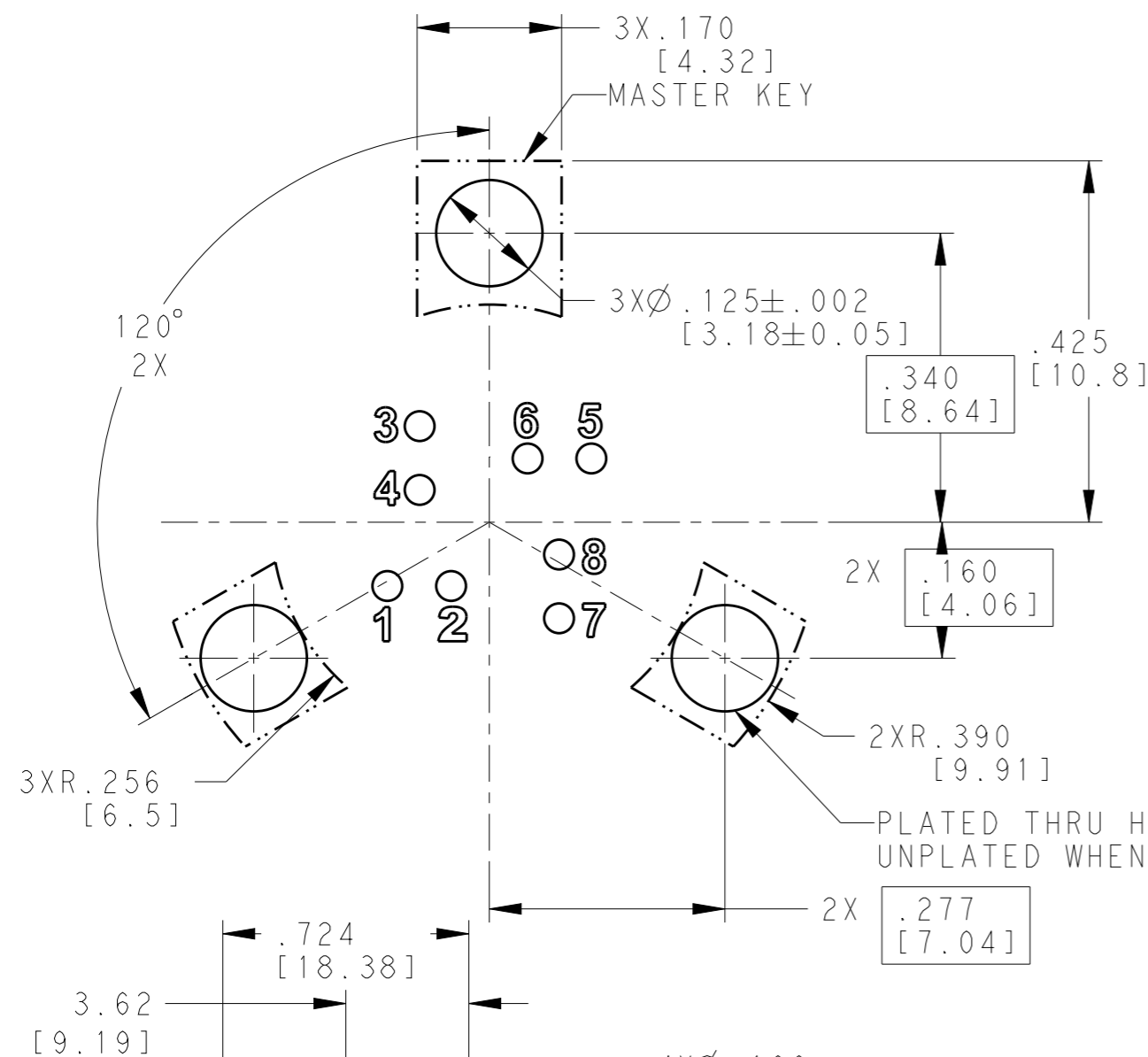

PANEL CUTOUT DIMENSIONS

THIS DRAWING IS A CONTROLLED DOCUMENT.
 DIMENSIONING AND TOLERANCING PER
 ASME Y14.5M (ISO STANDARDS)

DIMENSIONS:	TOLERANCES UNLESS OTHERWISE SPECIFIED:
INCHES [mm]	
	0 PLC \pm -
	1 PLC \pm -
	2 PLC \pm -
	3 PLC \pm .005 [0.13]
	4 PLC \pm -
	ANGLES \pm -

MATERIAL	FINISH
-	-

DWN 18AUG2011
 MCKIBBEN, JOHN

CHK 18AUG2011
 DOWHOWER, KENNETH

APVD 18AUG2011
 DOWHOWER, KENNETH

PRODUCT SPEC	-
APPLICATION SPEC	-
WEIGHT	-
CUSTOMER DRAWING	

TE Connectivity		NAME		RESTRICTED TO
		PCB RECEPTACLE MOUNT ASSEMBLY		
SIZE	CAGE CODE	DRAWING NO		
A3	00779	C-2102453		
SCALE 1:1		SHEET 2 OF 2	REV C	