

AT73C224-EK1 Evaluation Kit

User Guide





Table of Contents

Section 1

Introduction.....	1-1
1.1 Scope.....	1-1
1.2 AT73C224-EK1 Features.....	1-1
1.3 Deliverables	1-2

Section 2

Getting Started	2-1
2.1 Electrostatic Warning	2-1
2.2 Requirements.....	2-1
2.3 PC System Requirements.....	2-1
2.4 Instructions.....	2-2
2.4.1 To Start the AT73C224-EK1 Evaluation Board	2-2
2.4.2 To turn off the AT73C224-EK1 Evaluation Board.....	2-2
2.5 Block Diagram.....	2-3
2.6 Power Supply	2-4
2.6.1 Transformer	2-4
2.6.2 Power-up By A Battery	2-5
2.7 Dynamic/Static Modes	2-7
2.7.1 Dynamic Mode/Communication Interface Set Up.....	2-8
2.7.2 Static Mode.....	2-11
2.8 Real Time Clock (RTC).....	2-13
2.9 On-Board Output Signals.....	2-14
2.9.1 VBG	2-14
2.9.2 CK32 - RTC Output Clock	2-14
2.9.3 VCAPP and VCAPN	2-14
2.9.4 VINT	2-15
2.9.5 DL1	2-15
2.9.6 SW2.....	2-15
2.9.7 Voltage Measurements.....	2-16
2.9.8 Current Measurements	2-16

Section 3

AT73C224-EK1 Software Interface	3-1
3.1 Software Panel.....	3-1

Section 4	
Technical Specifications	4-1

Section 5	
PCB Layout	5-1

Section 6	
Schematics	6-1

Section 7	
Revision History	7-1
7.1 Revision History	7-1



Section 1

Introduction

Congratulations on your purchase of the AT73C224-EK1. It is designed to give designers a quick start to evaluate power management capability of the AT73C224 Analog Companion Power Management Unit and for prototyping and testing of new designs.

1.1 Scope

This document describes the AT73C224-EK1 Evaluation Kit dedicated to products based on the AT73C224 core. This board is designed to allow an easy evaluation of the products using demonstration software.

To increase its demonstration capabilities, this standalone board has two serial interfaces (Two-wire Interface (TWI) and Serial Peripheral Interface (SPI) via Parallel Port).

This User Guide acts as a general getting started aid as well as a complete technical reference for advanced users.

This document uses as reference, the AT73C224 [Datasheet, literature number 6266](#), available at www.atmel.com.

Typical Applications

- DECT Phones
- WLAN Portable Devices
- Multimedia Devices
- Portable Music Players

1.2 AT73C224-EK1 Features

The AT73C224-EK1 provides the following features:

- Power Supply
 - External Battery Connection
- On-board Resources
 - DC/DC Step-up Converter (BOOST) 3.3V to 5.0V, 1A, up to 90% Efficiency. Can be used as BUCK/BOOST in SEPIC Configuration,
 - DC/DC Step-down (BUCK) Synchronous Converter 0.9V to 3.4V, 500 mA, up to 90% Efficiency, Pulse Skipping Capabilities,
 - Two Low-Drop-Out Regulators: LDO3 & 4: 1.4V to 1.8V, 2.5V to 2.8V (100 mV Step), 3V, 3.3V 200 mA,
 - Ultra-low Power Real-Time Clock and Backup Battery Management

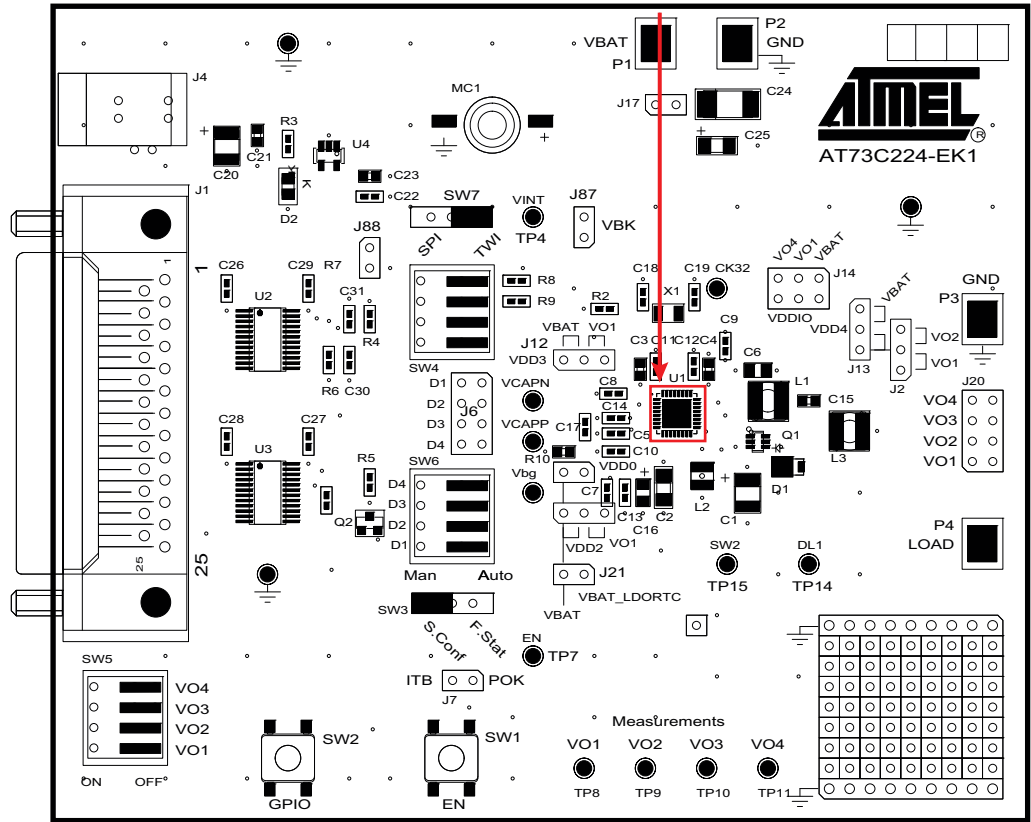
- 2.5V RTC LDO for Backup Battery Charging
- 32 kHz Crystal RTC Oscillator (1 μ A)
- RTC Circuit for Time and Date Information
- Activation of the Power Management Modules via Dedicated Enable Pin,
- Automatic Start-up Sequences, Power OK Signal Indicating when Start-up is Completed,
- Activation and Control of the Power Management Modules in Dynamic Mode (via SPI or TWI) or in Static Mode
- ITB Signal Indicating the Beginning of Shutdown
- Very Low Quiescent Current
- Minimum External Components Count
- Supply from 3V to 5.5V (typ: Li-Ion Battery 3V to 4.2V)
- Available in a 32-pin QFN 5x5 mm Package with Downbond Pin
- On-board Buttons
 - BUCK, LDO3 and LDO4 Supply Selection,
 - Digital Interface Power Selection
 - TWI/SPI Selection
 - Manual/Dynamic Mode Selection
 - Manual Output Power enabling
 - GPIO Enable

1.3 Deliverables

The AT73C224-EK1 package contains the following items:

- An AT73C224-EK1 Board
- One CD-ROM containing product software, User Guide and a full Datasheet
- 25-pin standard parallel cable

Figure 1-2. AT73C224-EK1 Components Side





2.1 Electrostatic Warning

The AT73C224-EK1 evaluation board is shipped in protective anti-static packaging. The board must not be subjected to high electrostatic potentials. A grounding strap or similar protective device should be connected when handling the board. Avoid touching the components, pins or any metallic element.

2.2 Requirements

In order to set up the AT73C224-EK1 evaluation kit the following items are needed:

1. The AT73C224-EK1 evaluation board itself.
2. DC output power source:
 - Transformer 5.5V to 9V DC max (minimum 200 mA is required)
 - External power supplies and/or battery (typ: Li-Ion Battery 3V to 4.2V) [see [Table 2-2, “Battery Types,” on page 2-5](#)]
3. PC station with a standard D-Type 25-pin standard communication port

2.3 PC System Requirements

For correct operation of the AT73C224-EK1 evaluation board, the minimum hardware and software PC requirements are:

- Intel® Pentium® II processor
- 64 MBytes RAM
- 70 MBytes free hard disk space (for AT73C224 Evaluation Board software installation). Software delivered on the CD with the Evaluation Board can also be found on the AT73C224-EK1 web page.
- Windows® NT/2000/XP
- Parallel port (COM port)

2.4 Instructions

2.4.1 To Start the AT73C224-EK1 Evaluation Board

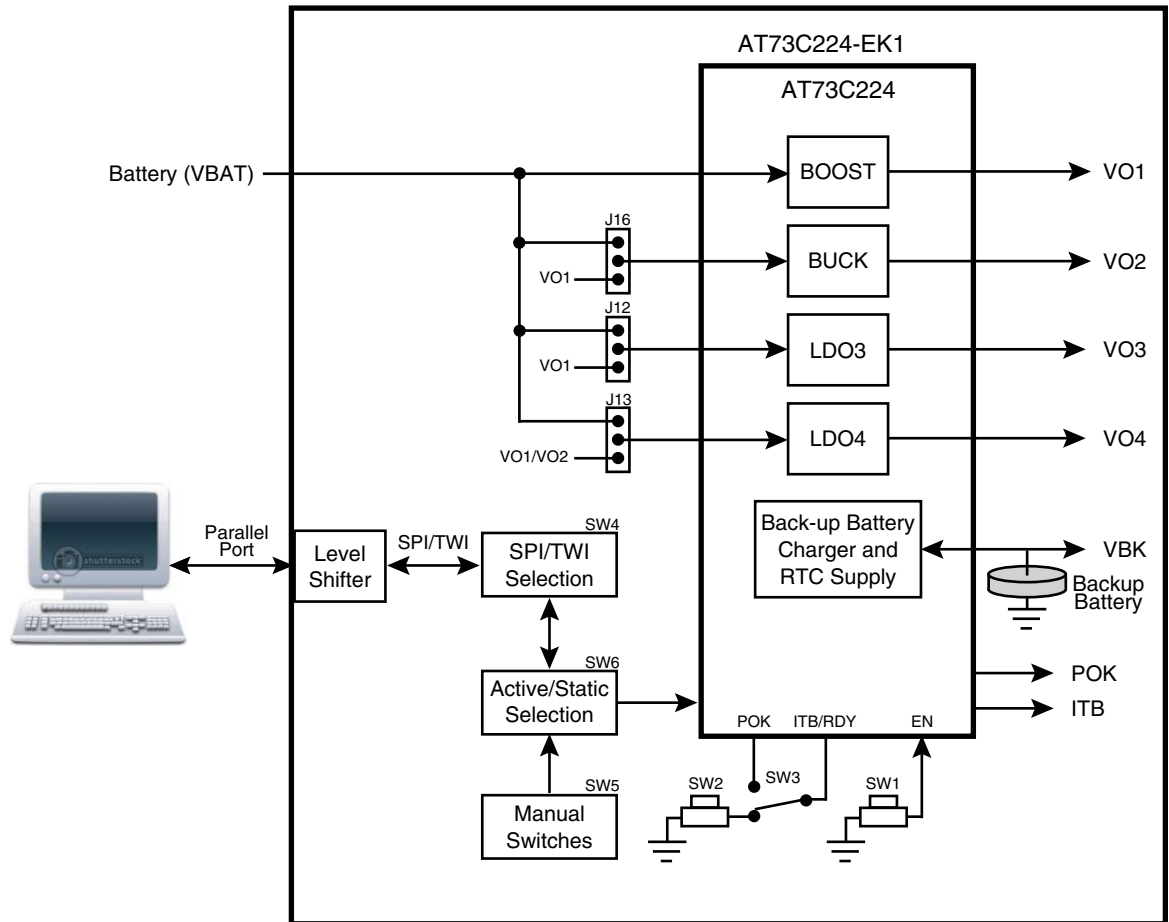
- Install «DLPORTIO.exe» from the provided software CD and restart your PC.
- Install the AT73C224 software by clicking on setup.exe.
- If the software is downloaded from the Atmel web site, it is necessary to first install the National Instrument Labview software (LabVIEW8.0.1RuntimeEngine).
- Configure the on-board jumpers and switches as described in the relevant paragraphs:
 1. [Section 2.6 "Power Supply" on page 2-4](#)
 2. [Section 2.7 "Dynamic/Static Modes" on page 2-7](#)
 3. [Section 2.8 "Real Time Clock \(RTC\)" on page 2-13](#)
- Connect the transformer.
- Connect the parallel port.
- Connect Input and Output devices.
- To launch the AT73C224 Test interface software, click on AT73C224.exe.

2.4.2 To turn off the AT73C224-EK1 Evaluation Board

- Click on the Shutdown button on the AT73C224 software
- Disconnect the chosen power supply

2.5 Block Diagram

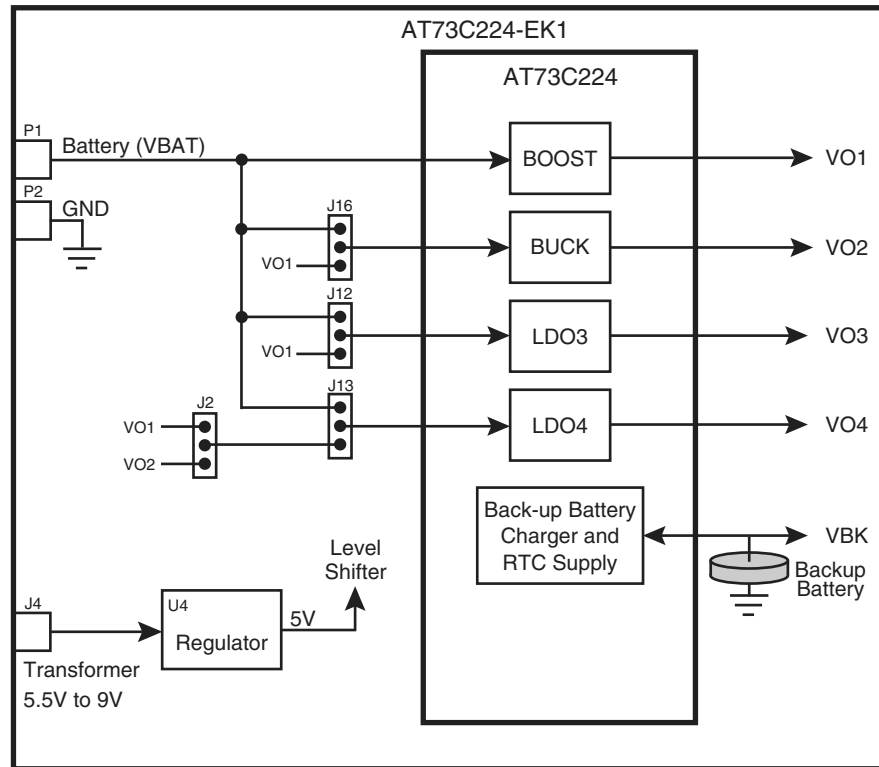
Figure 2-1. AT73C224-EK1 Block Diagram



2.6 Power Supply

The AT73C224-EK1 is supplied with the voltage sources shown below:

Figure 2-2. Power Supply Diagram



2.6.1 Transformer

The transformer is used to power the communication level shifter. Connect it when using the software.

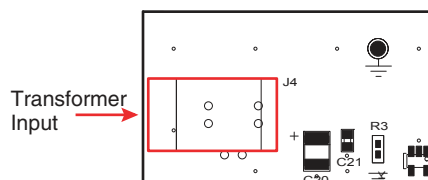
Table 2-1. Transformer Supply Voltage

Power Supply Source	Min	Max	Unit
Transformer (minimum 200 mA is required)	5.5	9	V

The power supply voltage is regulated with on board circuitry. Input voltage on this connector should be included between 5.5V and 9V.

Note: This power supply input is NOT protected against polarization inversion.

Figure 2-3. Transformer Connector (J4)



2.6.2 Power-up By A Battery

The AT73C224 can work with several types of battery as an external source:

- 2-cell Disposable Alkaline AA or AAA
- 2-cell NiMH/NiCd
- 1-cell Rechargeable Li-Ion

The two-cell battery types feature a voltage range of 1.8V - 3.2V, while the Li-Ion battery features a range of 3.0V - 4.2V.

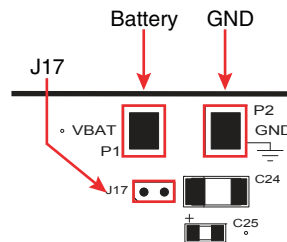
Table 2-2. Battery Types

Battery Type	Remarks	Battery Voltage Range		Units
		Min	Max	
1-cell Rechargeable Li-Ion	Factory fused	3.0	4.2	V
2-cell Disposable Alkaline AA or AAA		1.8	3.2	V
2-cell NiMH/NiCd				

In order to power-up the card by a battery do the following:

1. Connect the Battery (+) to the Battery pad and Battery (-) to GND pad.
2. Close J17 and J5.

Figure 2-4. Operating the AT73C224-EK1 With a Battery

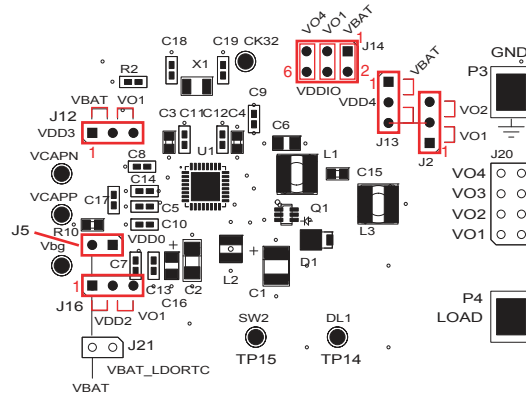


3. Configure the input voltages by closing the following jumpers (J16, J12, J13, J2 and J14):

Table 2-3. On Board Supply Selection Jumpers

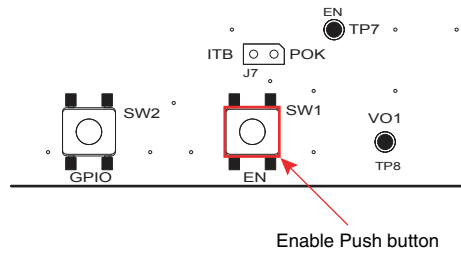
LDO N°	Selected Input Voltage			
	Vbat	VO1	VO2	VO4
VDD2 (J16)	Pins 1&2	Pins 2&3	-----	-----
VDD3 (J12)	Pins 1&2	Pins 2&3	-----	-----
VDD4 (J13 & J2)	Pins 1&2 (J13)	Pins 2&3 (J13) and Pins 1&2 (J2)	Pins 2&3 (J13) and Pins 2&3 (J2)	-----
VDDIO (J14)	Pins 1&2	Pins 3&4	-----	Pins 5&6

Figure 2-5. On Board Supply Jumpers



4. Push once on SW1 to enable start-up of the AT73C224.

Figure 2-6. Enable Push Button (SW1)



2.7 Dynamic/Static Modes

The AT73C224 supply management is performed in Dynamic or Static mode (Dynamic for SPI and TWI protocols).

The Dynamic/Static modes are factory fused and should be configured by each assembled AT73C224 version.

Please consult the following table for the available version.

Table 2-4. Available AT73C224 version

Part Number	Management Mode
AT73C224-A	Dynamic
AT73C224-B	Dynamic
AT73C224-C	Dynamic
AT73C224-D	Dynamic
AT73C224-E	Dynamic
AT73C224-F	Static
AT73C224-G	Static
AT73C224-H	Static

Dynamic/Static modes selection is done by setting SW6 according to the requested operation.

Figure 2-7. Dynamic Mode (SW6)

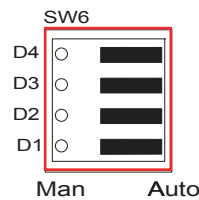
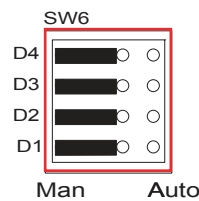


Figure 2-8. Static Mode (SW6)

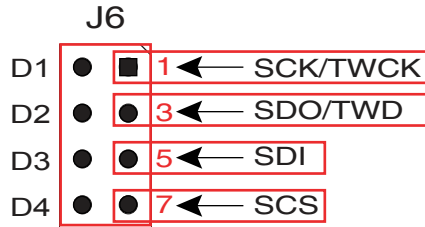


2.7.1 Dynamic Mode/Communication Interface Set Up

These boards enable controlling the AT73C224 via SPI/TWI through the parallel port (J1).

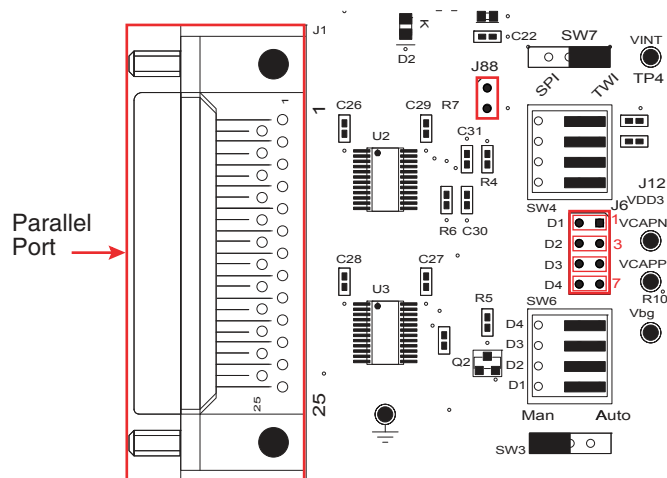
If the user wants to program the AT73C224 directly with a host extension, J6 can be removed and the Communication Port can be driven directly.

Figure 2-9. Direct Programming



The SPI/TWI communication protocols are described in the AT73C224 data sheet. In all cases of using the SPI/TWI interfaces through the parallel port, a transformer needs to be connected to J4, and J88 and J6 jumpers should be closed.

Figure 2-10. Communication Port and Jumpers Set Up (J1)



2.7.1.1 TWI Set Up

1. Close J6 and J88 jumpers.
2. Set SW4 switches to TWI position.
3. Set SW7 switch according to the requested TWI address (48 or 49).
4. Set SW6 to Auto mode (Dynamic).
5. Connect the transformer.
6. Connect the parallel port.

Figure 2-11. TWI Set Up With Address 48

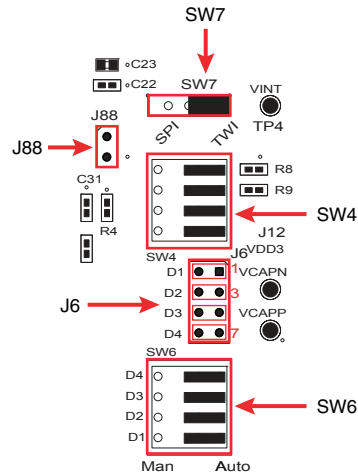
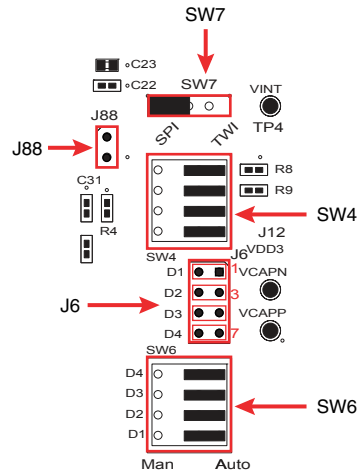


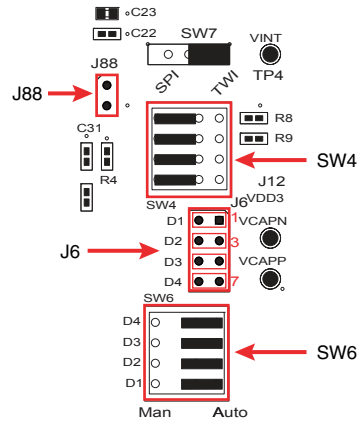
Figure 2-12. TWI Set Up With Address 49



2.7.1.2 SPI Set Up

1. Close J6 and J88 jumpers.
2. Set SW4 switches to SPI position.
3. Set SW6 to Auto mode (Dynamic).
4. Connect the transformer.
5. Connect the parallel port.

Figure 2-13. SPI Set Up



2.7.2 Static Mode

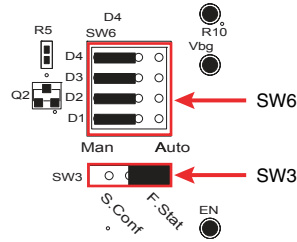
When the AT73C224-EK1 is established in Static Mode, the digital interface signals, D1 to D4, directly drive the enable of the four supplies. There are 3 Static Modes as follows:

2.7.2.1 Fully Static Mode

In order to establish Fully Static Mode do the following:

1. Set SW6 to Manual Mode.
2. Set SW3 to Fully Static Mode.

Figure 2-14. Fully Static Mode

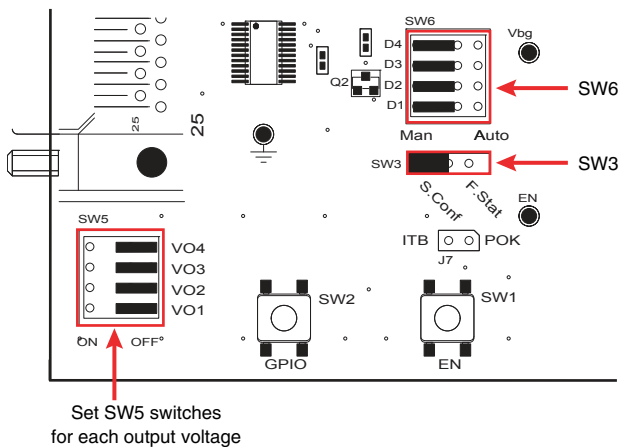


2.7.2.2 Configurable Static Mode

In order to establish Configurable Static Mode do the following:

1. Set SW6 switches to Manual Mode.
2. Set SW3 to Static Mode.
3. Set SW5 switches to enable the correct output voltage as required.

Figure 2-15. Configurable Static Mode

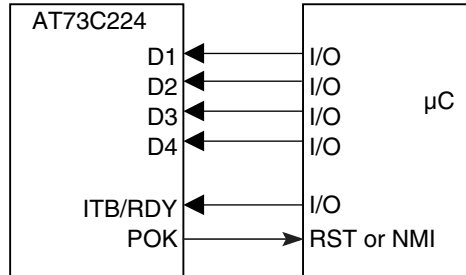


2.7.2.3 GPIO Mode (Microcontroller Controlled)

In order to establish GPIO Mode do the following:

1. Connect the microcontroller I/Os as required to D1 - D4 on J6 (see [Figure 2-9 on page 2-8](#))
2. Connect POK and ITB signals to the microcontroller.

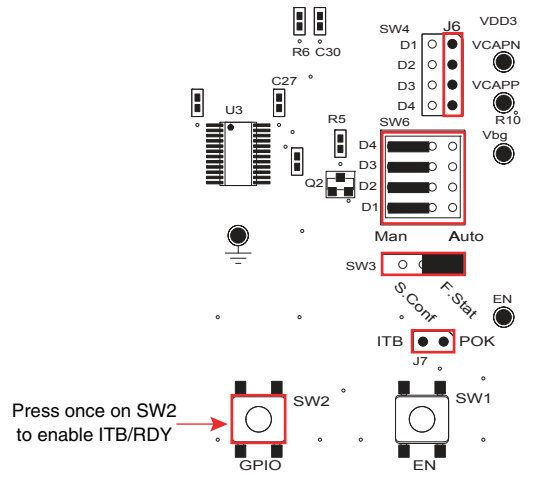
Figure 2-16. GPIO Mode Architecture



3. Set SW6 to Manual Mode.
4. Set SW3 to Fully Static Mode.
5. Connect ITB/RDY and POK (on J7) to μ C.

Note: If ITB/RDY is not connected to the microcontroller, it can be established manually by pressing once on the push button, SW2.

Figure 2-17. GPIO Mode

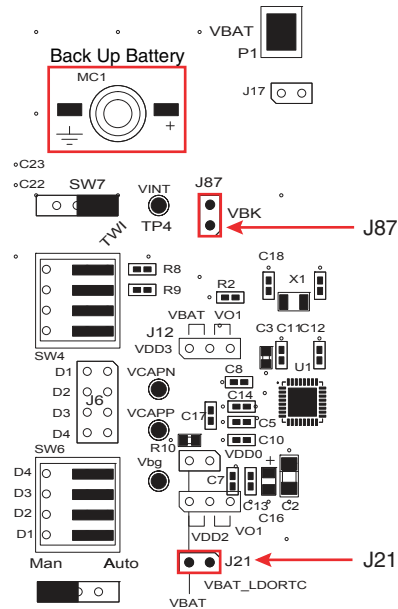


2.8 Real Time Clock (RTC)

When applying RTC Mode, set-up the following:

1. Close J21 jumper (or connect an Ampere meter in serial for current measurements).
2. Close J87 jumper (or connect an Ampere meter in serial for current measurements).

Figure 2-18. RTC Configurations



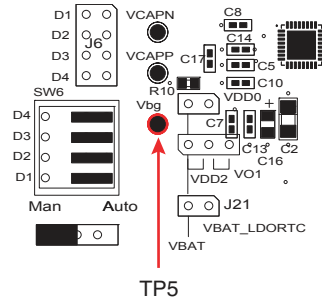
The coin-cell battery type used in the AT73C224-EK1 is MC621SM from Varta™.

2.9 On-Board Output Signals

2.9.1 VBG

The AT73C224-EK1 provides measurement of the internal Bandgap (TP5).

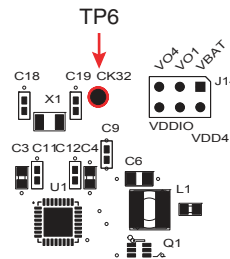
Figure 2-19. VBG (TP5)



2.9.2 CK32 - RTC Output Clock

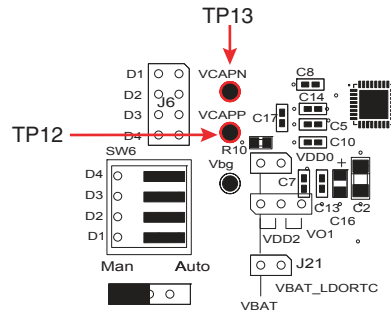
The AT73C224-EK1 provides measurement of the RTC 32 kHz output clock (TP6).

Figure 2-20. CK32- RTC Output Clock (TP6)



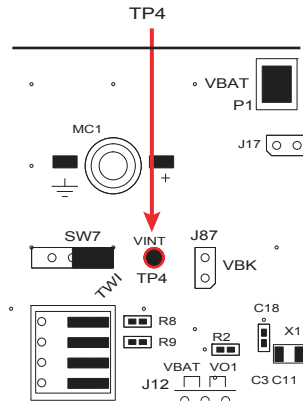
2.9.3 VCAPP and VCAPN

Figure 2-21. VCAPP and VCAPN (TP12 and TP13)



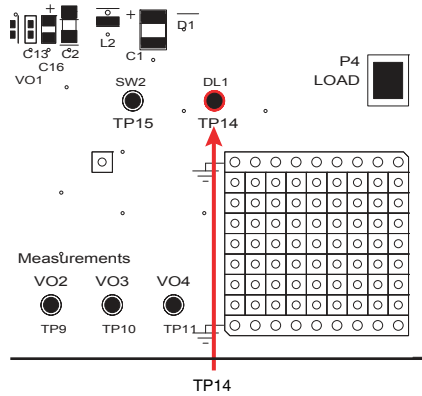
2.9.4 VINT

Figure 2-22. VINT (TP4)



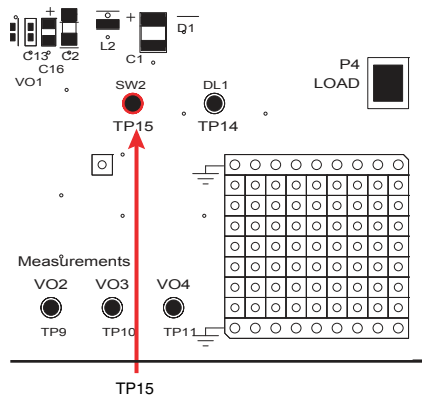
2.9.5 DL1

Figure 2-23. DL1 (TP14)



2.9.6 SW2

Figure 2-24. SW2 (TP15)

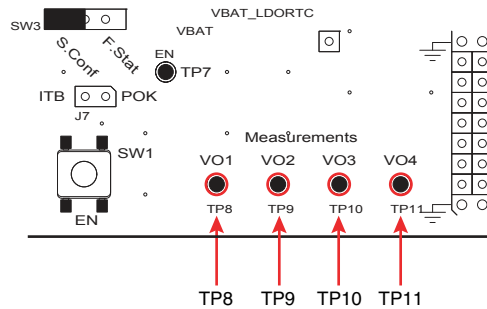


2.9.7 Voltage Measurements

In order to measure the output voltages connect a Voltage meter probe to the requested Test-Point by the following list:

- VO1 - TP8
- VO2 - TP9
- VO3 - TP10
- VO4 - TP11

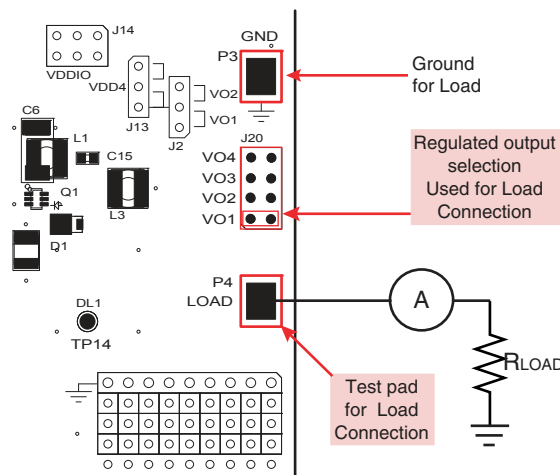
Figure 2-25. Output Voltage Test Points (TP8 - TP11)



2.9.8 Current Measurements

In order to measure the output current of VO1 to VO4, connect an Amper meter and a load resistor in serial to the load pad (P4) and close, with a jumper, the output voltage that you wish to measure (in J20). The P3 pad can be use as a Ground pad. (see [Figure 2-26](#) below for P4 and J20 locations).

Figure 2-26. Current Measurement on VBOOS



AT73C224-EK1 Software Interface

3.1 Software Panel

Figure 3-1. Software Panel - General Purpose Page

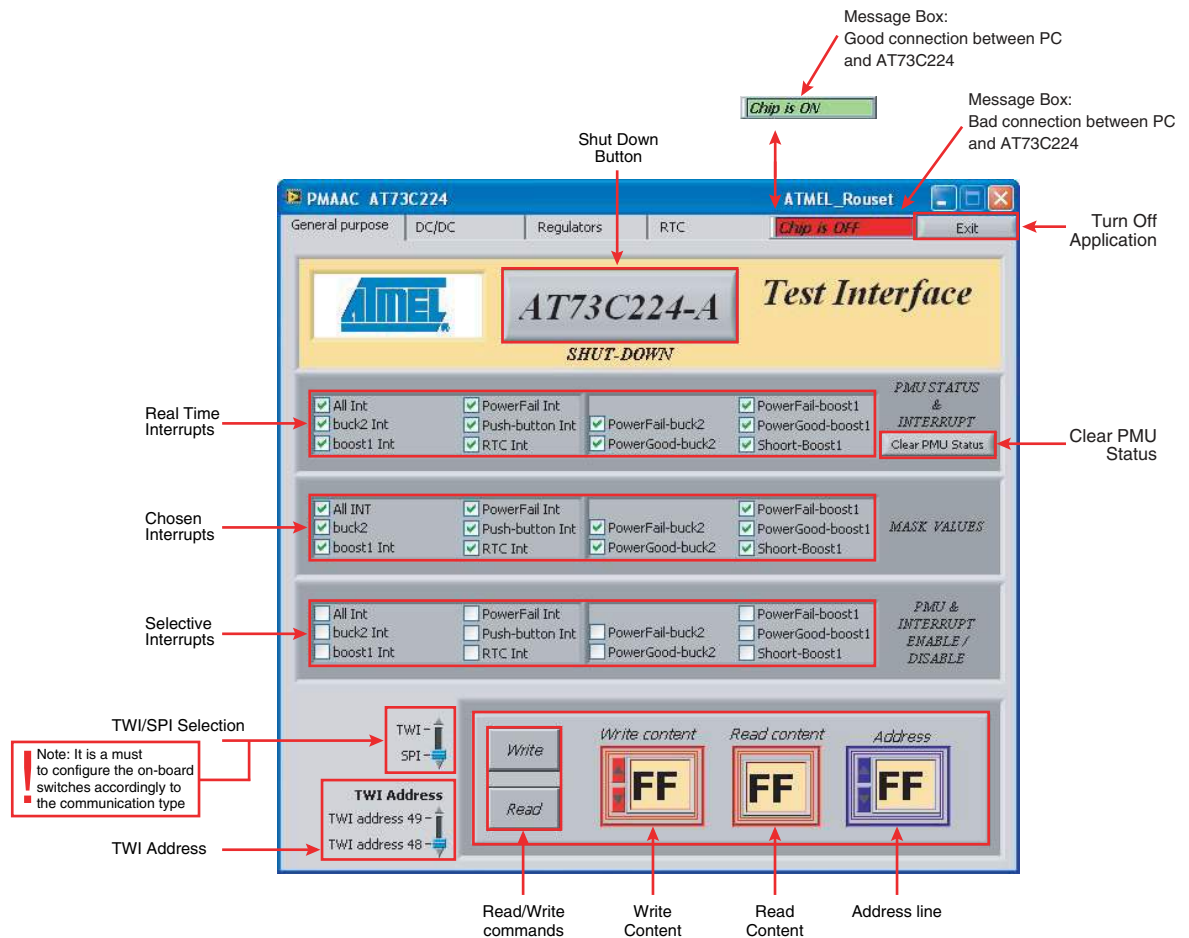


Figure 3-2. Software Panel - DC/DC Page

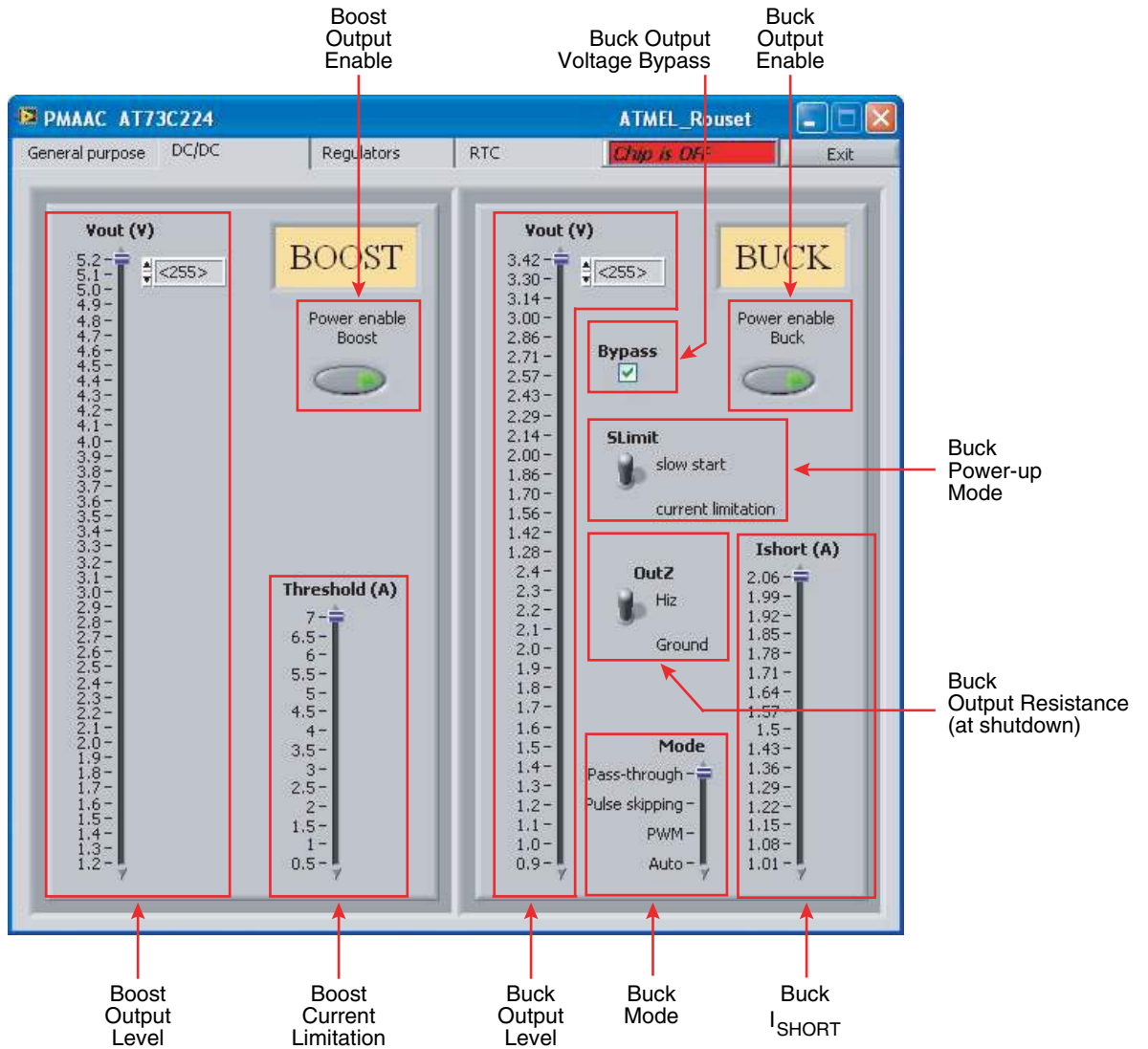


Figure 3-3. Software Panel - Regulators Page

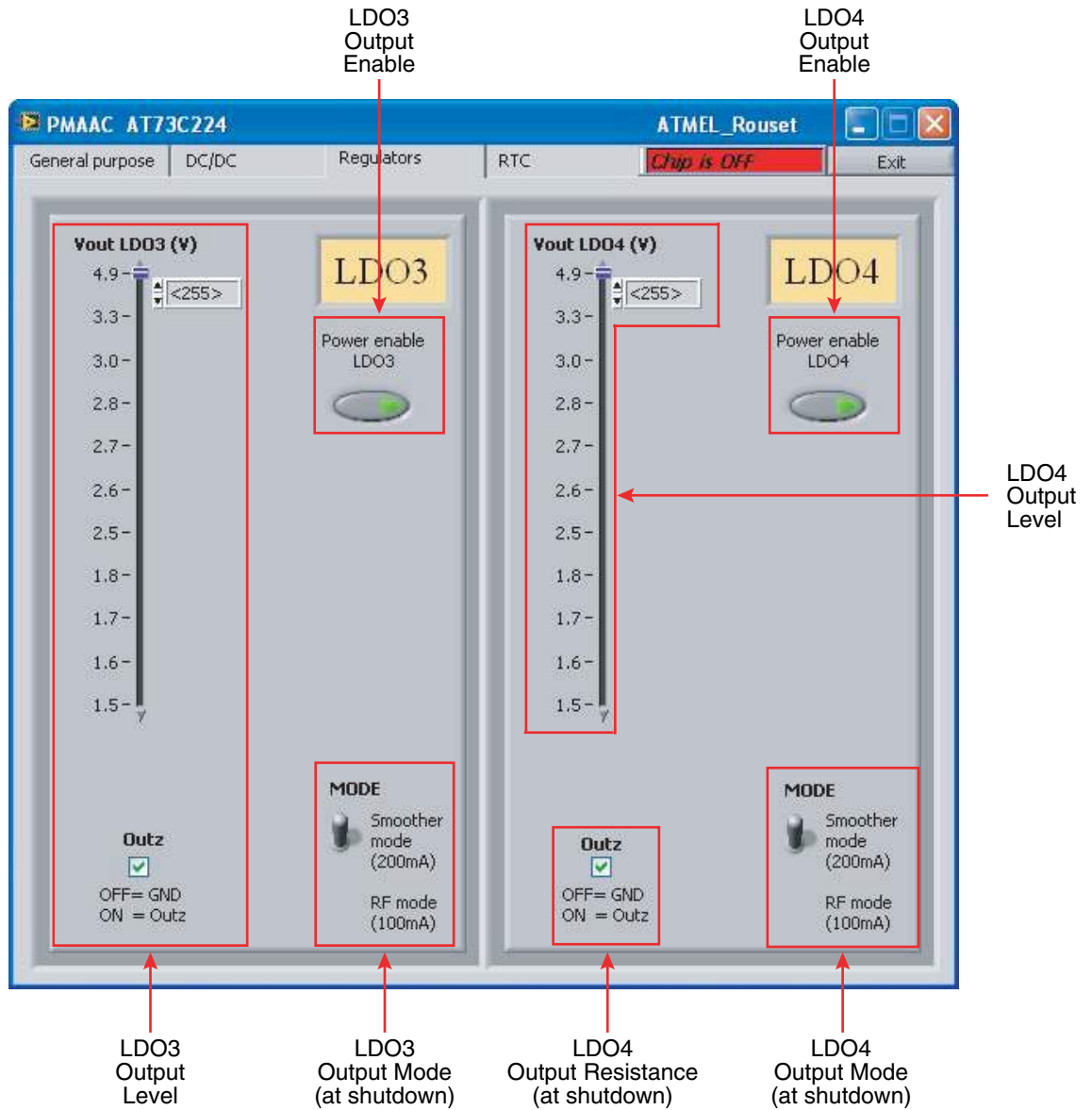


Figure 3-4. Software Panel - RTC Page

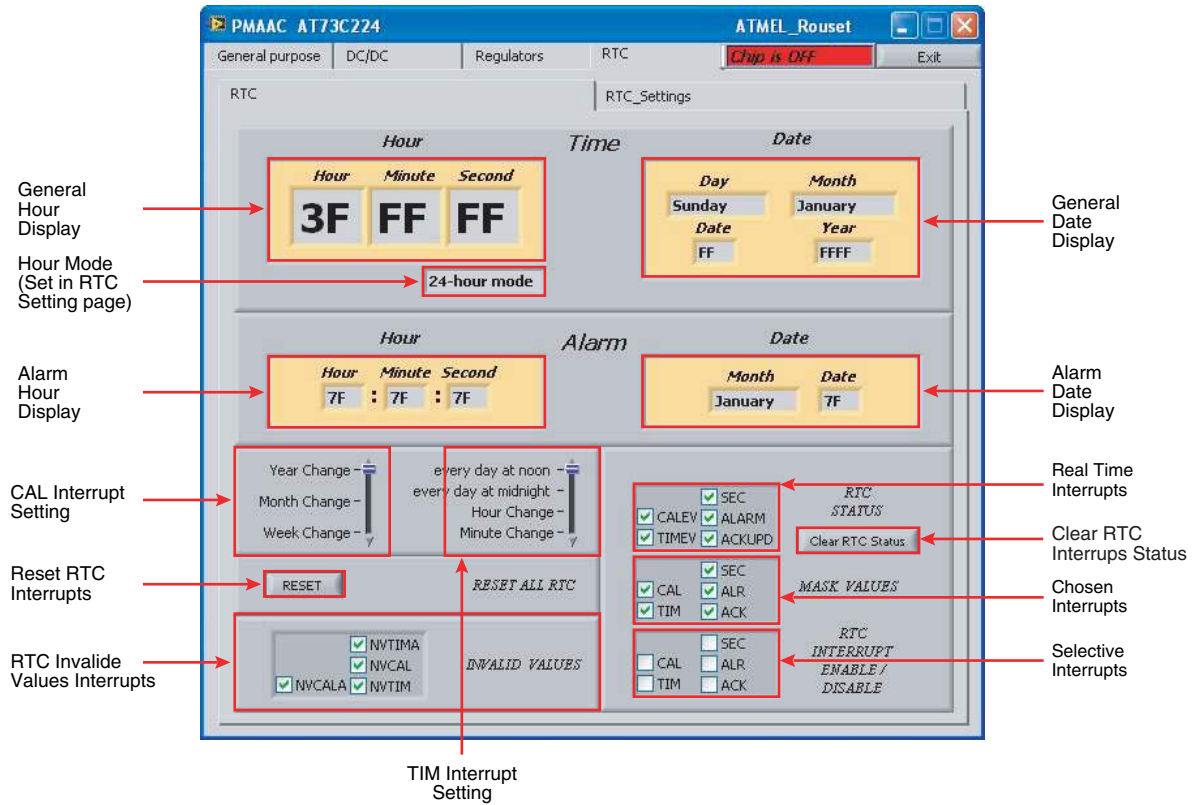
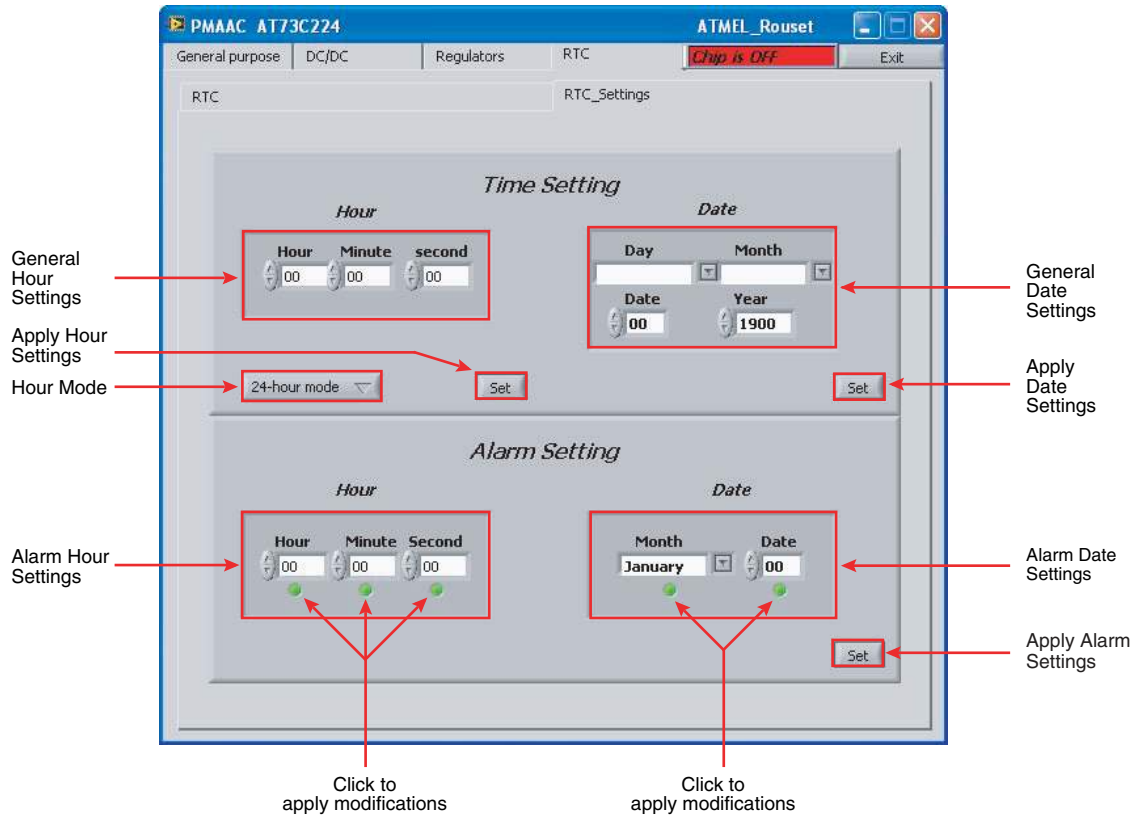


Figure 3-5. Software Panel - RTC Settings Page





Section 4

Technical Specifications

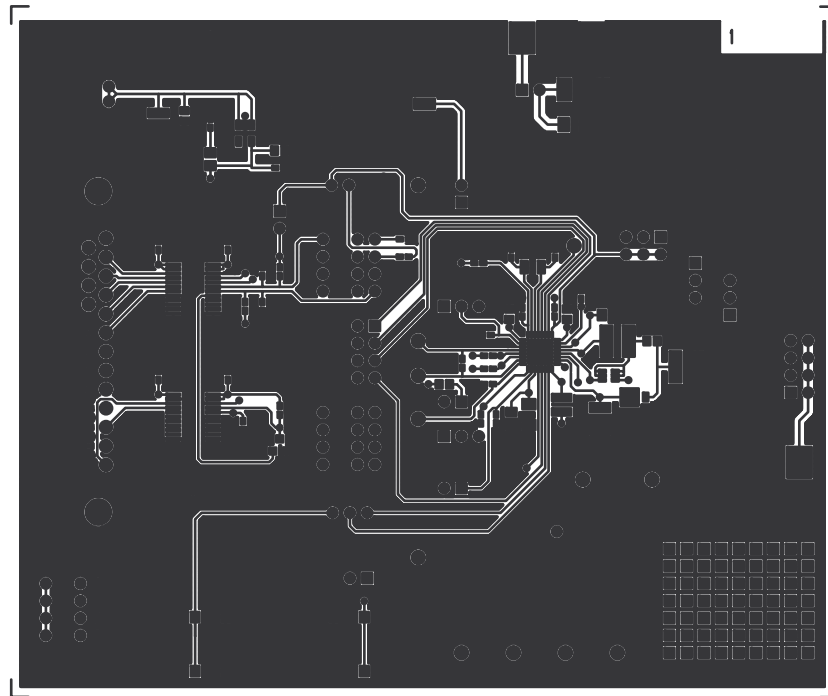
- System Unit
 - Physical Dimensions..... L= 120 x W = 60 x H = 20 mm
 - Weight.....50 g

- Operating Conditions
 - Voltage Supply (on VBAT).....1.8V - 4.2V
 - Voltage Supply (for Level Shifter).....5.5V - 9V

- Connections
 - Parallel Port Connector.....Sub D25 male

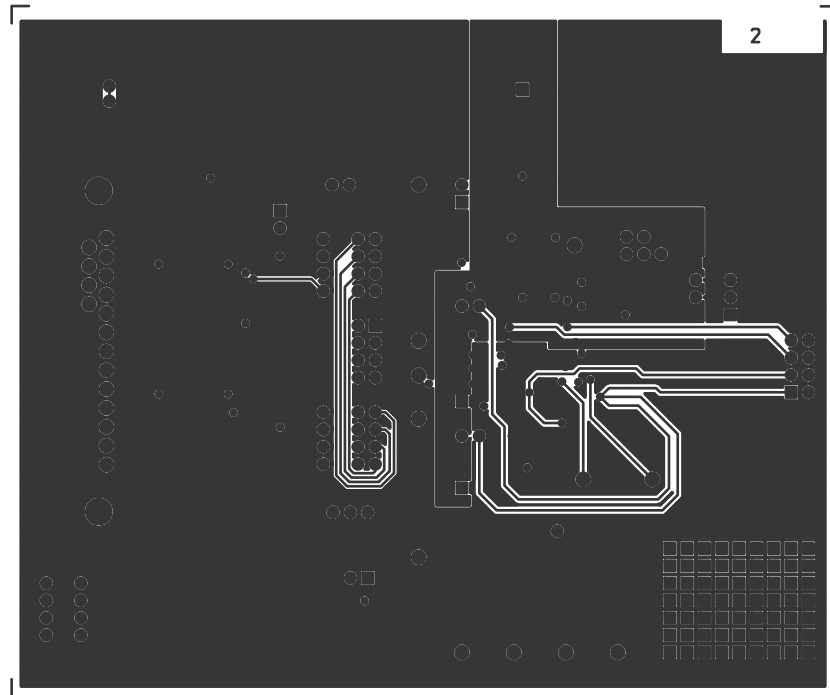


Figure 5-1. Layer 1 - Components Layer



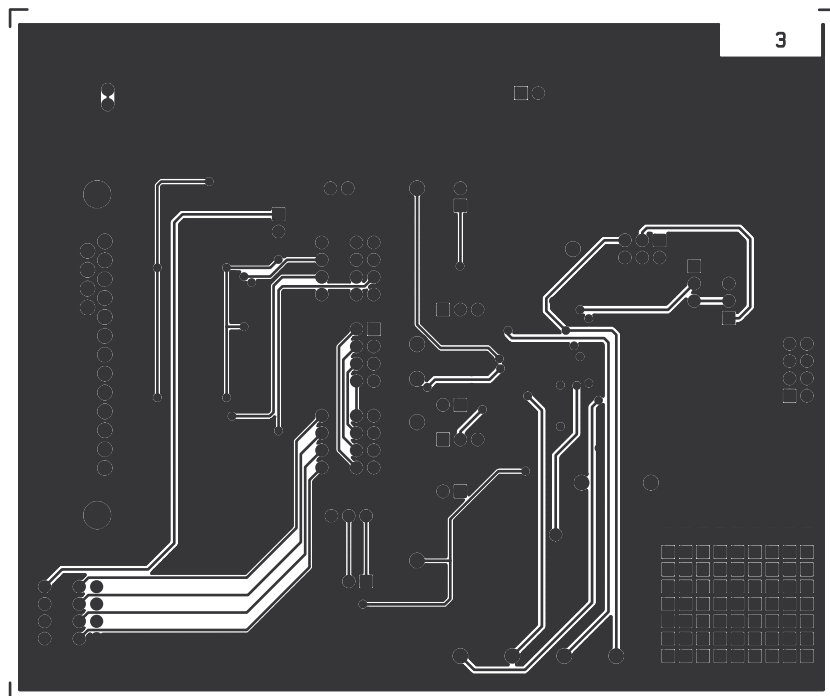
Note: Size not to be scaled.

Figure 5-2. Layer 2



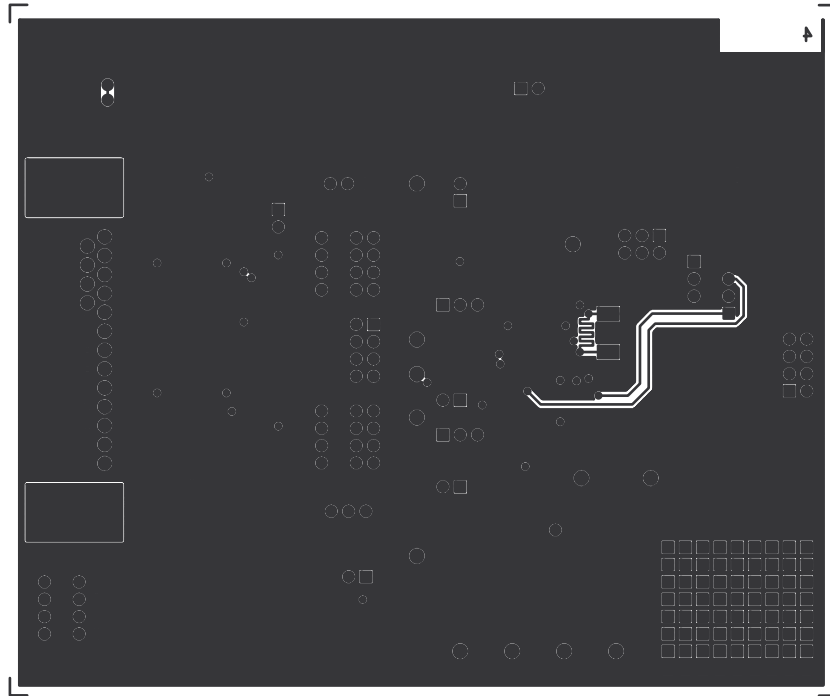
Note: Size not to be scaled.

Figure 5-3. Layer 3



Note: Size not to be scaled.

Figure 5-4. Layer 4 - Solder Layer



Note: Size not to be scaled.



Figure 6-1. AT73C224-EK1 Main Schematic Page

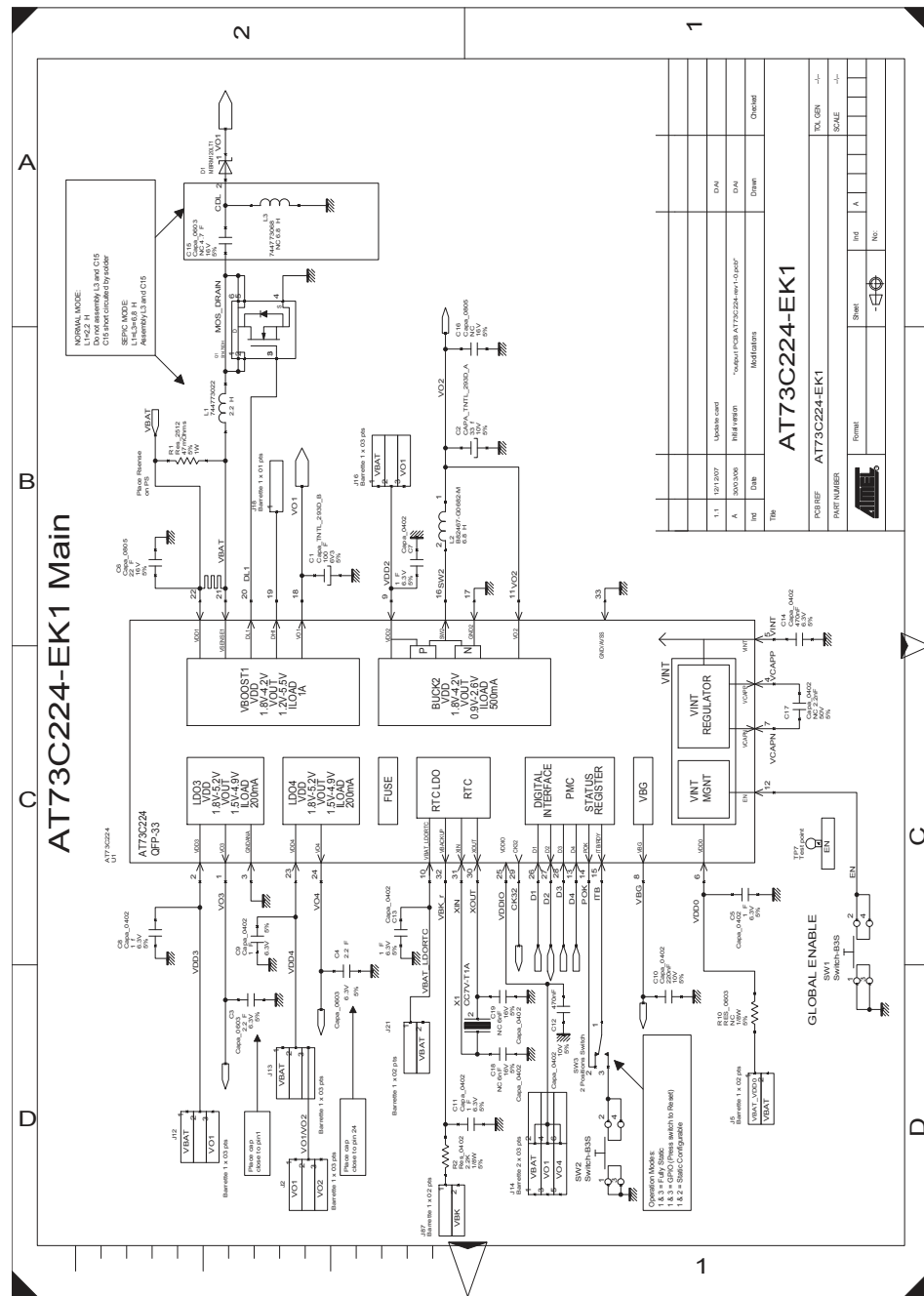


Figure 6-2. AT73C224-EK1 PC Interface Schematic Page

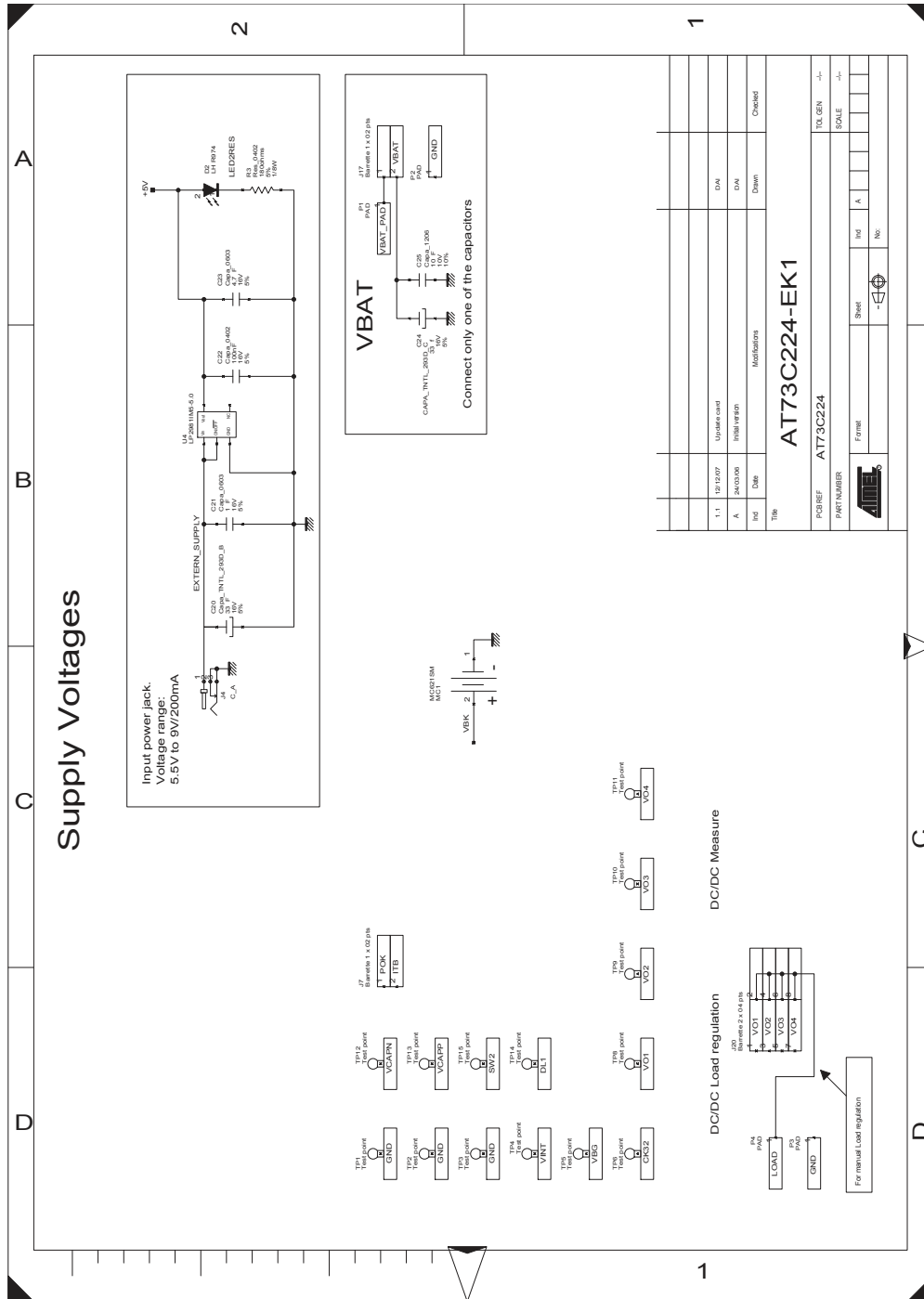
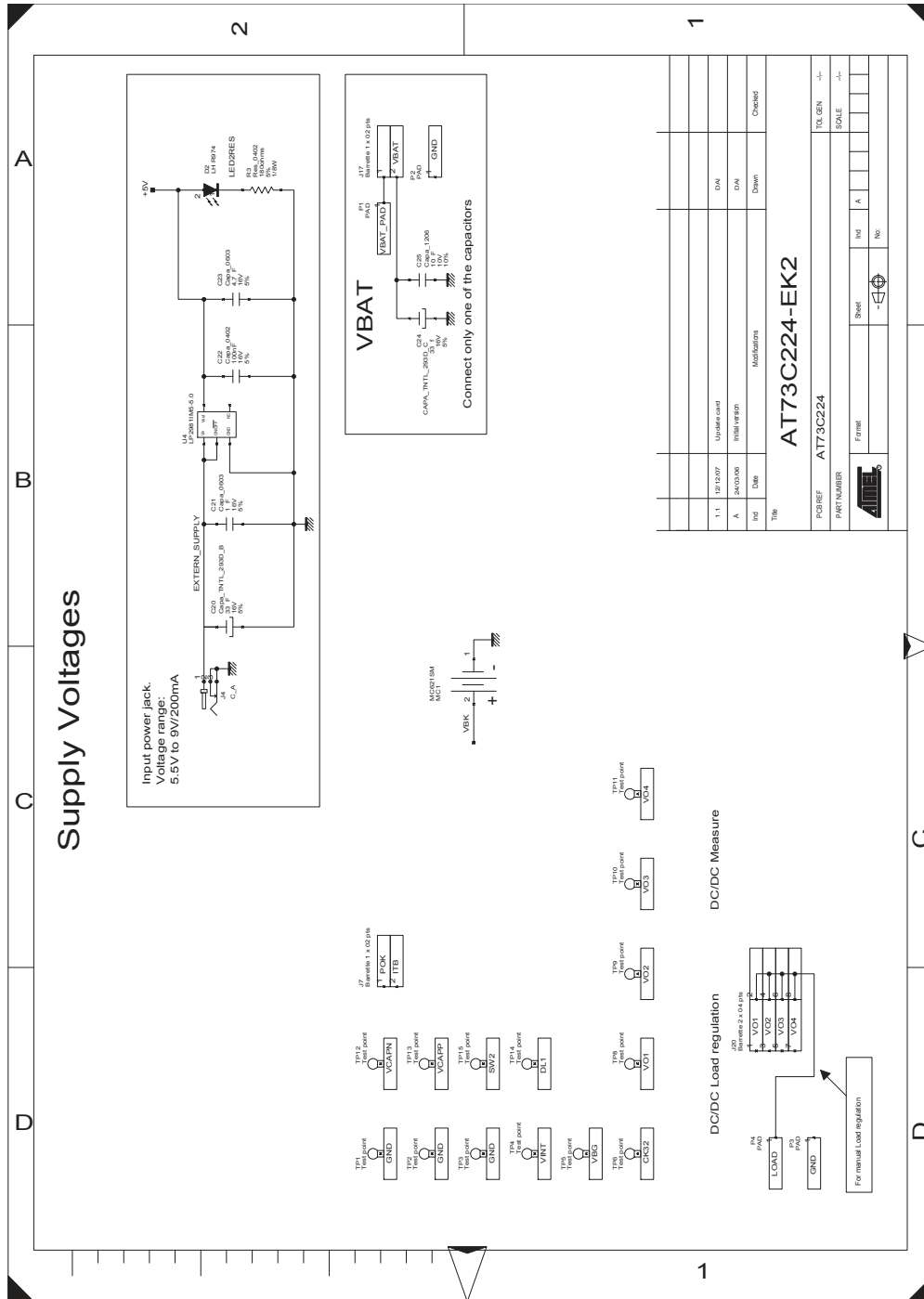


Figure 6-3. AT73C224-EK1 Supply And Measure Schematic Page





Section 7

Revision History

7.1 Revision History

Table 7-1. Revision History

Document	Comments	Change Request Ref.
6439A	First issue	



Headquarters

Atmel Corporation
2325 Orchard Parkway
San Jose, CA 95131
USA
Tel: 1(408) 441-0311
Fax: 1(408) 487-2600

International

Atmel Asia
Unit 1-5 & 16, 19/F
BEA Tower, Millennium City 5
418 Kwun Tong Road
Kwun Tong, Kowloon
Hong Kong
Tel: (852) 2245-6100
Fax: (852) 2722-1369

Atmel Europe
Le Krebs
8, Rue Jean-Pierre Timbaud
BP 309
78054 Saint-Quentin-en-
Yvelines Cedex
France
Tel: (33) 1-30-60-70-00
Fax: (33) 1-30-60-71-11

Atmel Japan
9F, Tonetsu Shinkawa Bldg.
1-24-8 Shinkawa
Chuo-ku, Tokyo 104-0033
Japan
Tel: (81) 3-3523-3551
Fax: (81) 3-3523-7581

Product Contact

Web Site
www.atmel.com
www.atmel.com/PMAAC

Technical Support
Atmel technical support
pmaac@atmel.com

Sales Contacts
www.atmel.com/contacts/

Literature Requests
www.atmel.com/literature

Disclaimer: The information in this document is provided in connection with Atmel products. No license, express or implied, by estoppel or otherwise, to any intellectual property right is granted by this document or in connection with the sale of Atmel products. **EXCEPT AS SET FORTH IN ATMEL'S TERMS AND CONDITIONS OF SALE LOCATED ON ATMEL'S WEB SITE, ATMEL ASSUMES NO LIABILITY WHATSOEVER AND DISCLAIMS ANY EXPRESS, IMPLIED OR STATUTORY WARRANTY RELATING TO ITS PRODUCTS INCLUDING, BUT NOT LIMITED TO, THE IMPLIED WARRANTY OF MERCHANTABILITY, FITNESS FOR A PARTICULAR PURPOSE, OR NON-INFRINGEMENT. IN NO EVENT SHALL ATMEL BE LIABLE FOR ANY DIRECT, INDIRECT, CONSEQUENTIAL, PUNITIVE, SPECIAL OR INCIDENTAL DAMAGES (INCLUDING, WITHOUT LIMITATION, DAMAGES FOR LOSS OF PROFITS, BUSINESS INTERRUPTION, OR LOSS OF INFORMATION) ARISING OUT OF THE USE OR INABILITY TO USE THIS DOCUMENT, EVEN IF ATMEL HAS BEEN ADVISED OF THE POSSIBILITY OF SUCH DAMAGES.** Atmel makes no representations or warranties with respect to the accuracy or completeness of the contents of this document and reserves the right to make changes to specifications and product descriptions at any time without notice. Atmel does not make any commitment to update the information contained herein. Unless specifically provided otherwise, Atmel products are not suitable for, and shall not be used in, automotive applications. Atmel's products are not intended, authorized, or warranted for use as components in applications intended to support or sustain life.

© 2009 Atmel Corporation. All rights reserved. Atmel®, Atmel logo and combinations thereof, and others are registered trademarks or trademarks of Atmel Corporation or its subsidiaries. Windows® and others are registered trademarks of Microsoft Corporation in the US and/or other countries. Other terms and product names may be trademarks of others.