Description

The 74AHCT1G126 is a single non-inverting buffer/bus driver with a 3-state output. The output enters a high impedance state when a LOW-level is applied to the output enable (OE) pin. The device is designed for operation with a power supply range of 4.5V to 5.5V.

Features

- Supply Voltage Range from 4.5V to 5.5V
- ± 8 mA Output Drive at 5.0V
- CMOS low power consumption
- Schmitt Trigger Action at All Inputs Make the Circuit Tolerant for Slower Input Rise and Fall Time.
- ESD Protection per JESD 22
 - Exceeds 200-V Machine Model (A115-A)
 - Exceeds 2000-V Human Body Model (A114-A)
 - Exceeds 1000-V Charged Device Model (C101C)
- Latch-Up Exceeds 100mA per JESD 78, Class II
- SOT25 and SOT353: Assembled with "Green" Molding Compound (no Br, Sb)
- Lead Free Finish / RoHS Compliant (Note 1)

Notes: 1. EU Directive 2002/95/EC (RoHS). All applicable RoHS exemptions applied. Please visit our website at http://www.diodes.com/products/lead_free.html.

Pin Assignments

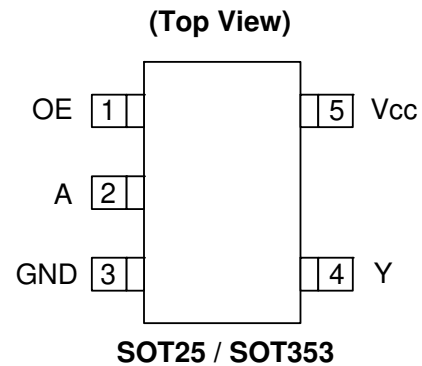

Applications

- General Purpose Logic
- Wide array of products such as:
 - PCs, networking, notebooks, netbooks, PDAs
 - Computer peripherals, hard drives, CD/DVD ROM
 - TV, DVD, DVR, set top box
 - Phones, Personal Navigation / GPS
 - MP3 players, Cameras, Video Recorders

Pin Descriptions

Pin Name	Pin No.	Description
OE	1	Output Enable
A	2	Data Input
GND	3	Ground
Y	4	Data Output
V _{CC}	5	Supply Voltage

Logic Diagram

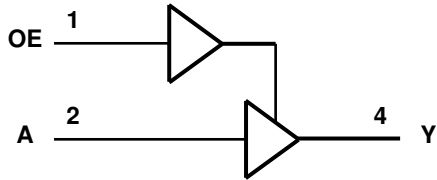

Function Table

Inputs		Output
OE	A	Y
H	H	H
H	L	L
L	X	Z

Absolute Maximum Ratings (Note 2)

Symbol	Description	Rating	Unit
ESD HBM	Human Body Model ESD Protection	2	KV
ESD CDM	Charged Device Model ESD Protection	1	KV
ESD MM	Machine Model ESD Protection	200	V
V _{CC}	Supply Voltage Range	-0.5 to 6.5	V
V _I	Input Voltage Range	-0.5 to 6.5	V
V _O	Voltage applied to output in high or low state	-0.5 to V _{CC} +0.5	V
I _{IK}	Input Clamp Current V _I <0	-20	mA
I _{OK}	Output Clamp Current (V _O < 0 or V _O > V _{CC})	±20	mA
I _O	Continuous output current (V _O = 0 to V _{CC})	±25	mA
I _{CC}	Continuous current through V _{CC}	50	mA
I _{GND}	Continuous current through GND	-50	mA
T _J	Operating Junction Temperature	-40 to 150	°C
T _{STG}	Storage Temperature	-65 to 150	°C

Notes: 2. Stresses beyond the absolute maximum may result in immediate failure or reduced reliability. These are stress values and device operation should be within recommend values.

Recommended Operating Conditions (Note 3)

Symbol	Parameter	Min	Max	Unit
V _{CC}	Operating Voltage	4.5	5.5	V
V _{IH}	High-level Input Voltage	2.0		V
V _{IL}	Low-level input voltage		0.8	V
V _I	Input Voltage	0	5.5	V
V _O	Output Voltage	0	V _{CC}	V
I _{OH}	High-level output current		-8	mA
I _{OL}	Low-level output current		8	mA
Δt/ΔV	Input transition rise or fall rate		20	ns/V
T _A	Operating free-air temperature	-40	125	°C

Notes: 3. Unused inputs should be held at V_{CC} or Ground.

Electrical Characteristics

Symbol	Parameter	Test Conditions	V _{CC}	25°C			-40°C to 85°C		-40°C to 125°C		Unit
				Min	Typ.	Max	Min	Max	Min	Max	
V _{OH}	High Level Output Voltage	I _{OH} = -50μA	4.5V	4.4	4.5		4.4		4.4		V
		I _{OH} = -8mA	4.5V	3.94			3.8		3.70		
V _{OL}	Low Level Output Voltage	I _{OL} = 50μA	4.5V		0	0.1		0.1		0.1	V
		I _{OL} = 8mA	4.5V			0.36		0.44		0.55	
I _I	Input Current	V _I = 5.5V or GND	0 to 5.5V			± 0.1		± 1		± 2	μA
I _{OZ}	Z State Leakage Current	V _O = 0 to 5.5V	5.5V			0.25		2.5		10	μA
I _{CC}	Supply Current	V _I = 5.5V or GND I _O = 0	5.5V			1		10		40	μA
C _i	Input Capacitance	V _I = V _{CC} – or GND	5.5V		2.0	10		10		10	pF
ΔI _{CC}	Additional Supply Current	One input at 3.4 V Other inputs at V _{CC} or GND	5.5V			1.35		1.5			mA
θ _{JA}	Thermal Resistance Junction-to-Ambient	SOT25	(Note 4)		204						°C/W
		SOT353			371						
θ _{JC}	Thermal Resistance Junction-to-Case	SOT25	(Note 4)		52						°C/W
		SOT353			143						

Note: 4. Test conditions for SOT25, and SOT353: Device mounted on FR-4 substrate PC board, 2oz copper, with minimum recommended pad layout.

Switching Characteristics

$V_{CC} = 5V \pm 0.5V$ (see Figure 1)

Parameter	From (Input)	TO (OUTPUT)		25°C			-40°C to 85°C		-40°C to 125°C		Unit
				Min	Typ.	Max	Min	Max	Min	Max	
t_{pd}	A	Y	$C_L=15pF$	0.6	3.4	5.5	0.6	6.5	0.6	7.0	ns
			$C_L=50pF$	0.6	4.7	7.5	0.6	8.5	0.6	9.5	ns
t_{en}	OE	Y	$C_L=15pF$	0.6	3.6	5.6	0.6	6.3	0.6	6.5	ns
			$C_L=50pF$	0.6	5.4	8.0	0.6	9.0	0.6	9.0	ns
t_{dis}	OE	Y	$C_L=15pF$	0.6	4.3	6.8	0.6	8.0	0.6	8.5	ns
			$C_L=50pF$	0.6	6.1	8.8	0.6	10.0	0.6	11.0	ns

Operating Characteristics

$T_A = 25^\circ C$

Parameter		Test Conditions	$V_{CC} = 5V$	Unit
			Typ.	
C_{pd}	Power dissipation capacitance	f = 1 MHz No Load	11	pF

Parameter Measurement Information

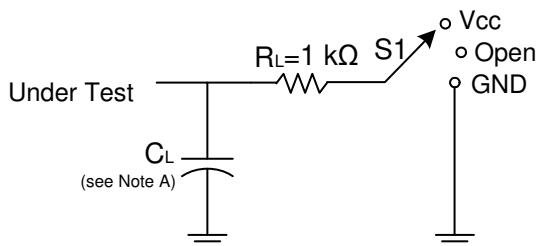

TEST	S1
t_{PLH}/t_{PHL}	Open
t_{PLZ}/t_{PZL}	Vload
t_{PHZ}/t_{PZH}	GND

Vcc	Inputs		VM	CL	VΔ
	VI	tr/td			
5V±0.5V	VCC	≤3ns	VCC/2	15pF	0.3V
5V±0.5V	VCC	≤3ns	VCC/2	50pF	0.3V

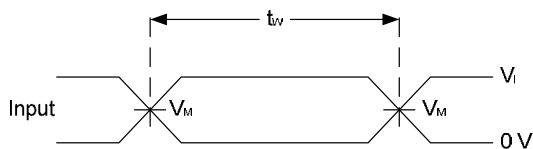

Voltage Waveform Pulse Duration

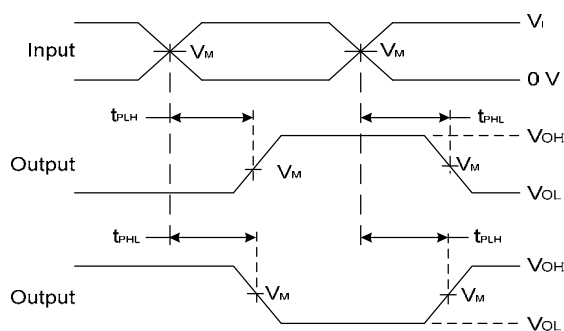

**Voltage Waveform Propagation Delay Times
Inverting and Non Inverting Outputs**

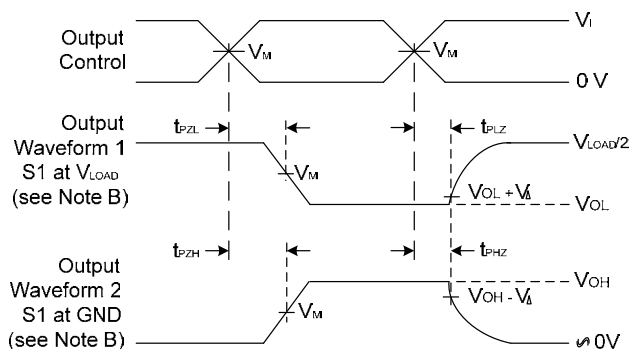

**Voltage Waveform Enable and Disable Times
Low and High Level Enabling**

Figure 1. Load Circuit and Voltage Waveforms

- Notes:
- A. Includes test lead and test apparatus capacitance.
 - B. All pulses are supplied at pulse repetition rate ≤ 1 MHz.
 - C. Inputs are measured separately one transition per measurement.
 - D. t_{PLZ} and t_{PHZ} are the same as t_{dis} .
 - E. t_{PZL} and t_{PZH} are the same as t_{EN} .
 - F. t_{PLH} and t_{PHL} are the same as t_{PD} .

Ordering Information

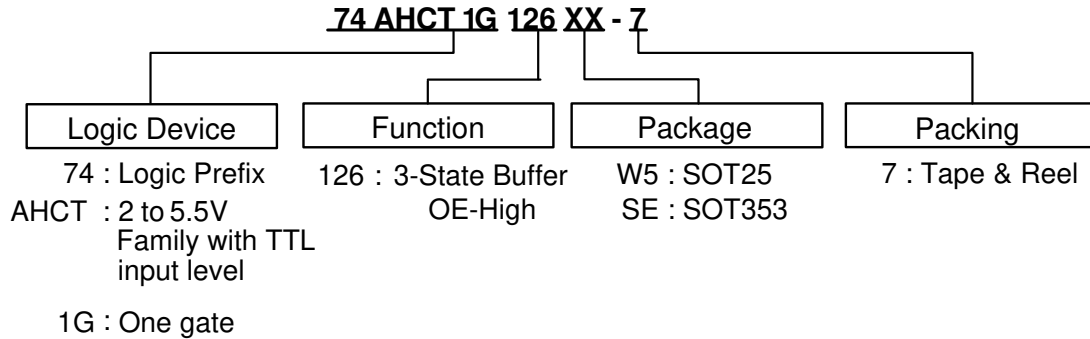

Device	Package Code	Packaging (Note 5)	7" Tape and Reel	
			Quantity	Part Number Suffix
74AHCT1G126W5-7	W5	SOT25	3000/Tape & Reel	-7
74AHCT1G126SE-7	SE	SOT353	3000/Tape & Reel	-7

Notes: 5. Pad layout as shown on Diodes Inc. suggested pad layout document AP02001, which can be found on our website at <http://www.diodes.com/datasheets/ap02001.pdf>.

Marking Information

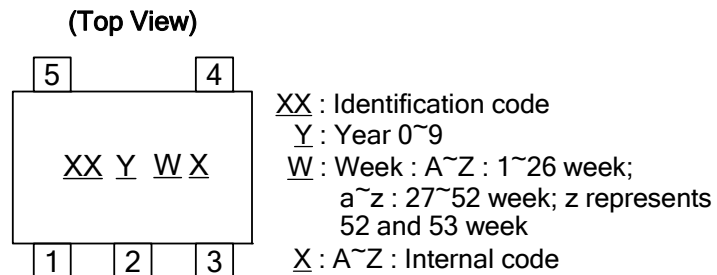

Part Number	Package	Identification Code
74AHCT1G126W5	SOT25	ZZ
74AHCT1G126SE	SOT353	ZZ

NEW PRODUCT

Package Outline Dimensions (All Dimensions in mm)

(1) Package Type: SOT25

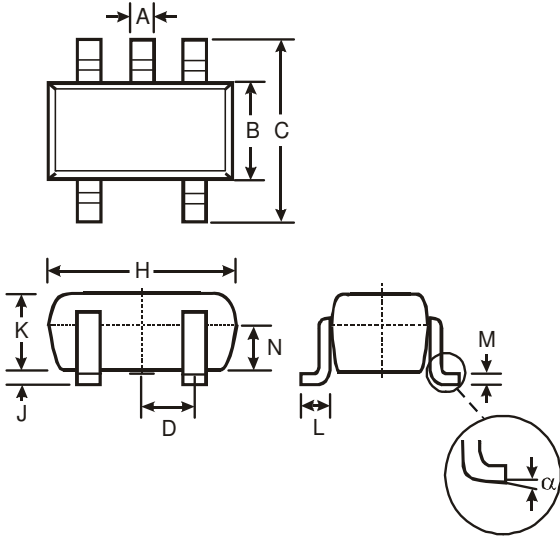

SOT25			
Dim	Min	Max	Typ
A	0.35	0.50	0.38
B	1.50	1.70	1.60
C	2.70	3.00	2.80
D	—	—	0.95
H	2.90	3.10	3.00
J	0.013	0.10	0.05
K	1.00	1.30	1.10
L	0.35	0.55	0.40
M	0.10	0.20	0.15
N	0.70	0.80	0.75
α	0°	8°	—
All Dimensions in mm			

(2) Package Type: SOT353

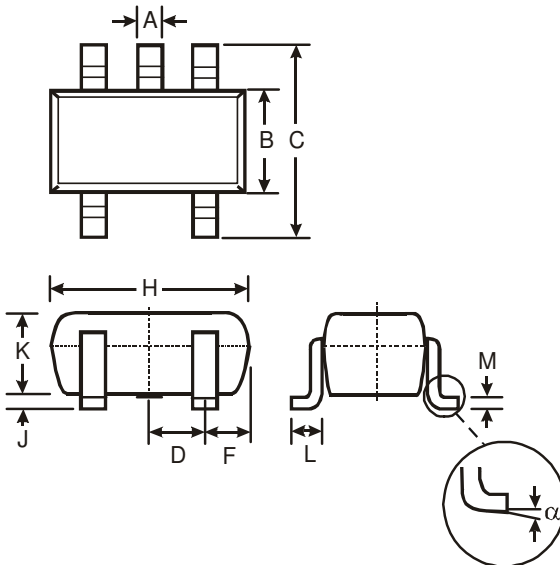

SOT353		
Dim	Min	Max
A	0.10	0.30
B	1.15	1.35
C	2.00	2.20
D	0.65 Typ	
F	0.40	0.45
H	1.80	2.20
J	0	0.10
K	0.90	1.00
L	0.25	0.40
M	0.10	0.22
α	0°	8°
All Dimensions in mm		

IMPORTANT NOTICE

DIODES INCORPORATED MAKES NO WARRANTY OF ANY KIND, EXPRESS OR IMPLIED, WITH REGARDS TO THIS DOCUMENT, INCLUDING, BUT NOT LIMITED TO, THE IMPLIED WARRANTIES OF MERCHANTABILITY AND FITNESS FOR A PARTICULAR PURPOSE (AND THEIR EQUIVALENTS UNDER THE LAWS OF ANY JURISDICTION).

Diodes Incorporated and its subsidiaries reserve the right to make modifications, enhancements, improvements, corrections or other changes without further notice to this document and any product described herein. Diodes Incorporated does not assume any liability arising out of the application or use of this document or any product described herein; neither does Diodes Incorporated convey any license under its patent or trademark rights, nor the rights of others. Any Customer or user of this document or products described herein in such applications shall assume all risks of such use and will agree to hold Diodes Incorporated and all the companies whose products are represented on Diodes Incorporated website, harmless against all damages.

Diodes Incorporated does not warrant or accept any liability whatsoever in respect of any products purchased through unauthorized sales channel.

Should Customers purchase or use Diodes Incorporated products for any unintended or unauthorized application, Customers shall indemnify and hold Diodes Incorporated and its representatives harmless against all claims, damages, expenses, and attorney fees arising out of, directly or indirectly, any claim of personal injury or death associated with such unintended or unauthorized application.

Products described herein may be covered by one or more United States, international or foreign patents pending. Product names and markings noted herein may also be covered by one or more United States, international or foreign trademarks.

LIFE SUPPORT

Diodes Incorporated products are specifically not authorized for use as critical components in life support devices or systems without the express written approval of the Chief Executive Officer of Diodes Incorporated. As used herein:

A. Life support devices or systems are devices or systems which:

1. are intended to implant into the body, or
2. support or sustain life and whose failure to perform when properly used in accordance with instructions for use provided in the labeling can be reasonably expected to result in significant injury to the user.

B. A critical component is any component in a life support device or system whose failure to perform can be reasonably expected to cause the failure of the life support device or to affect its safety or effectiveness.

Customers represent that they have all necessary expertise in the safety and regulatory ramifications of their life support devices or systems, and acknowledge and agree that they are solely responsible for all legal, regulatory and safety-related requirements concerning their products and any use of Diodes Incorporated products in such safety-critical, life support devices or systems, notwithstanding any devices- or systems-related information or support that may be provided by Diodes Incorporated. Further, Customers must fully indemnify Diodes Incorporated and its representatives against any damages arising out of the use of Diodes Incorporated products in such safety-critical, life support devices or systems.

Copyright © 2011, Diodes Incorporated

www.diodes.com