

Sequential Linear LED Driver

Features

- Minimal Component Count
(Base Configuration: CL8801 + Four Resistors + Diode Bridge)
- No Magnetics, No Capacitors
- Up to 7.5W Output (13W with Heat Sink)
- >110 Lm/W using Efficient LEDs
- 85% Typical Electrical Efficiency
- >0.95 Power Factor
- <30% THD Line Current
- Low Conducted EMI without Filters
- 85% LED Luminous Utilization
- Phase Dimmer Compatible with an RC Network

Applications

- Fluorescent Tube Retrofit
- Incandescent and CFL Bulb Replacement
- General LED Lighting

General Description

The CL8801 is designed to drive a long string of inexpensive, low-current LEDs directly from the AC mains. A basic driver circuit consists of CL8801, four resistors and a bridge rectifier. Two to four additional components are optional for various levels of transient protection. No capacitors, EMI filters or power factor correction circuits are needed.

A string of series/parallel LEDs is tapped at four locations. Four linear current regulators sink current at each tap and are sequentially turned on and off, thereby tracking the input sine wave voltage. Voltage across each regulator is minimized when conducting, providing high efficiency. Output current at each tap is individually resistor-adjustable. Cross-regulation, as the CL8801 switches from one regulator to another, provides smooth transitions. The current waveform can be tailored to optimize for input voltage range, line/load regulation, output power/current, efficiency, power factor, THD, dimmer compatibility and LED utilization.

With the addition of an RC network, the driver is compatible with phase dimming.

Package Type

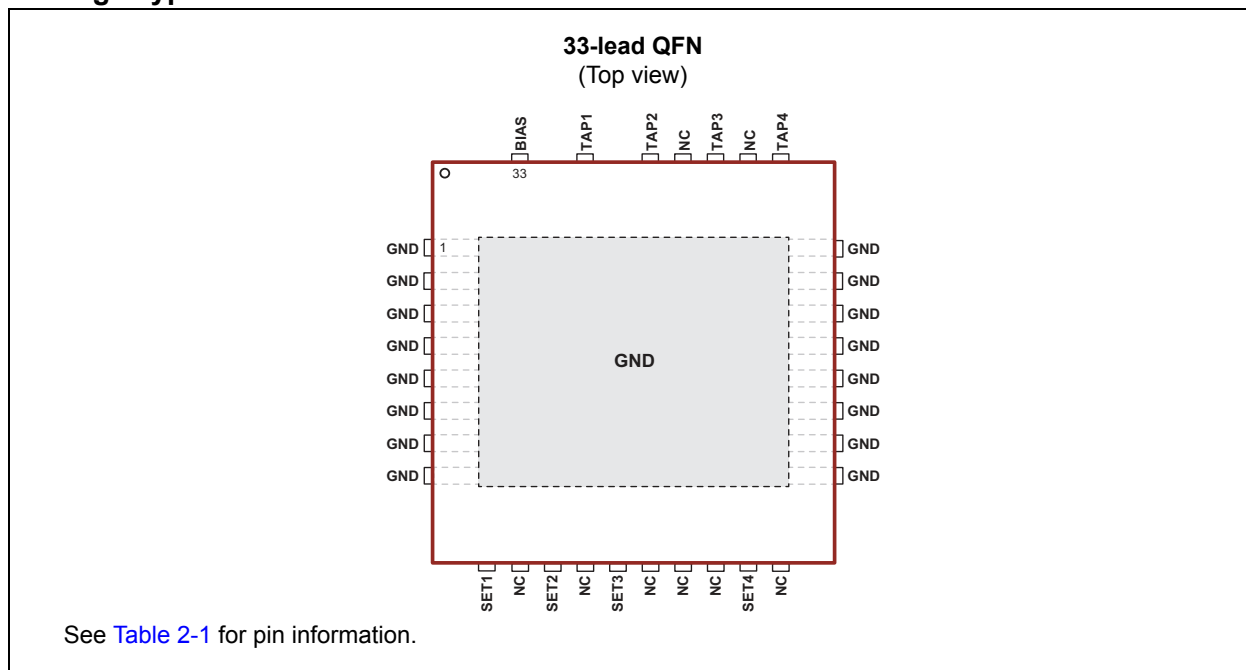

CL8801

Functional Block Diagram

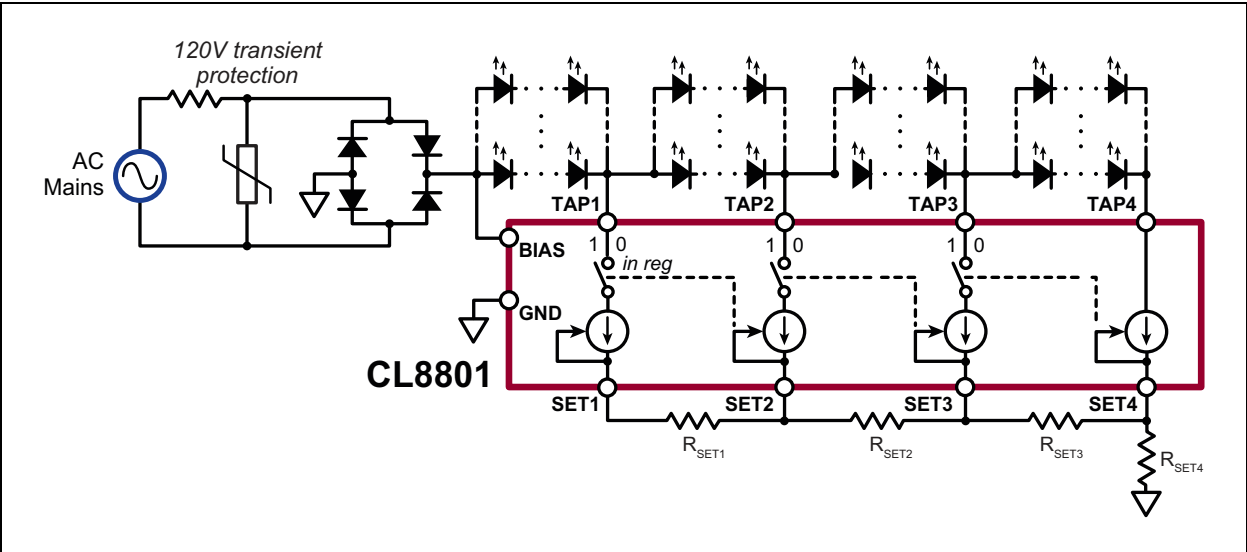

Typical Application Circuit

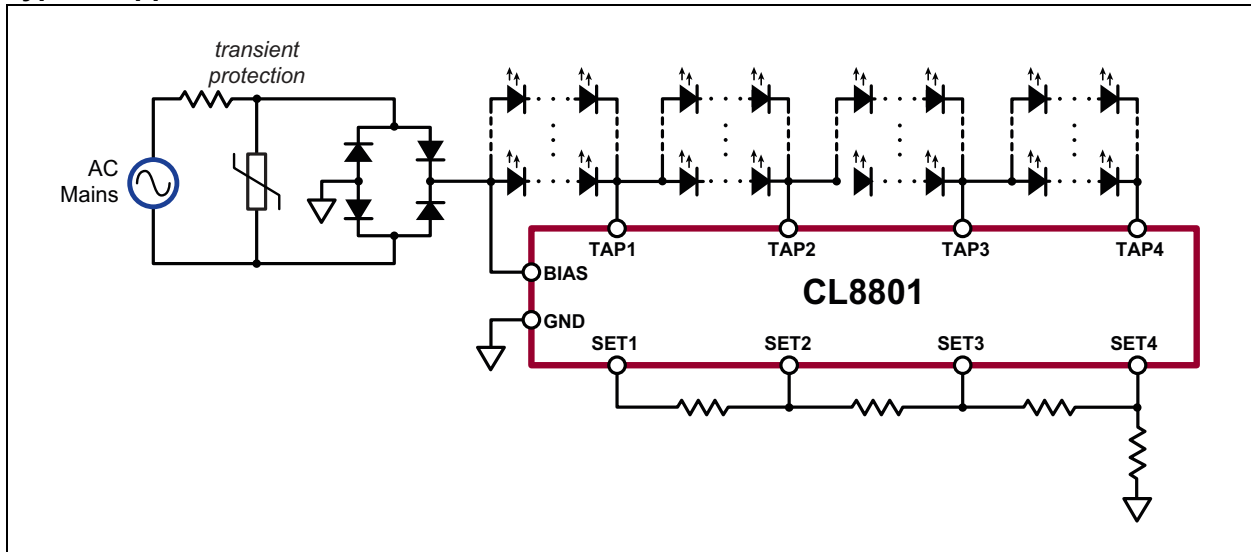

CL8801

1.0 ELECTRICAL CHARACTERISTICS

Absolute Maximum Ratings†

V_{BIAS}, V_{TAP1}	-0.5V to +550V
V_{TAP2-4}	-0.5V to +320V
V_{SET1-4}	4V
Operating Junction Temperature, T_J	-55°C to +125°C
Storage Temperature, T_S	-65°C to +150°C

† **Notice:** Stresses above those listed under “Absolute Maximum Ratings” may cause permanent damage to the device. This is a stress rating only, and functional operation of the device at those or any other conditions above those indicated in the operational sections of this specification is not intended. Exposure to maximum rating conditions for extended periods may affect device reliability.

RECOMMENDED OPERATING CONDITIONS

Electrical Specifications: All voltages with respect to GND pin							
Parameter	Sym.	Min.	Typ.	Max.	Unit	Conditions	
Output Current	TAP1	I_{OUT}	—	—	60	mA	
	TAP2		—	—	90		
	TAP3		—	—	200		
	TAP4		—	—	200		
Output Voltage	TAP1	V_{OUT}	—	—	400	V	Non-conducting
	TAP2–4		—	—	300		Non-conducting
	TAP1–4		—	—	Note 1		Conducting
Applied BIAS Voltage	V_{BIAS}	—	—	440	V		

Note 1: Voltage capability is determined by power dissipation ($V \times I$).

ELECTRICAL CHARACTERISTICS

Electrical Specifications: Over recommended operating conditions at 25°C unless noted otherwise							
Parameter	Sym.	Min.	Typ.	Max.	Unit	Conditions	
BIAS Pin Input Current	I_{BIAS}	—	250	410	μA	$V_{BIAS} = 170V$	
Output Current, On	TAP1	$I_{TAP(ON)}$	60	—	—	mA	$V_{TAP1} = 30V, V_{SET1-4} = GND$
	TAP2		90	—	—		$V_{TAP2} = 17V, V_{SET1-4} = GND$
	TAP3		200	—	—		$V_{TAP3} = 17V, V_{SET1-4} = GND$
	TAP4		200	—	—		$V_{TAP4} = 17V, V_{SET1-4} = GND$
Output Current, Off	$I_{TAP(OFF)}$	—	0	10	μA	Tap 1–3, $V_{BIAS} = 170V$	
Regulation Voltage at SET Pins	SET1–3	V_{REG}	1.8	2	2.2	V	
	SET4		1.89	2.1	2.31	V	

TEMPERATURE SPECIFICATIONS

Parameter	Sym.	Min.	Typ.	Max.	Unit	Conditions
TEMPERATURE RANGE						
Operating Junction Temperature	T_J	-55	—	+125	°C	
Storage Temperature	T_S	-65	—	+150	°C	
PACKAGE THERMAL RESISTANCE						
33-Lead QFN	θ_{JA}	—	24	—	°C/W	Note 1
	θ_{JC}	—	2.5	—	°C/W	Note 2

Note 1: One oz Cu four-layer board, 3 x 4-inch PCB with thermal pad and thermal via array

2: Junction to exposed heat slug

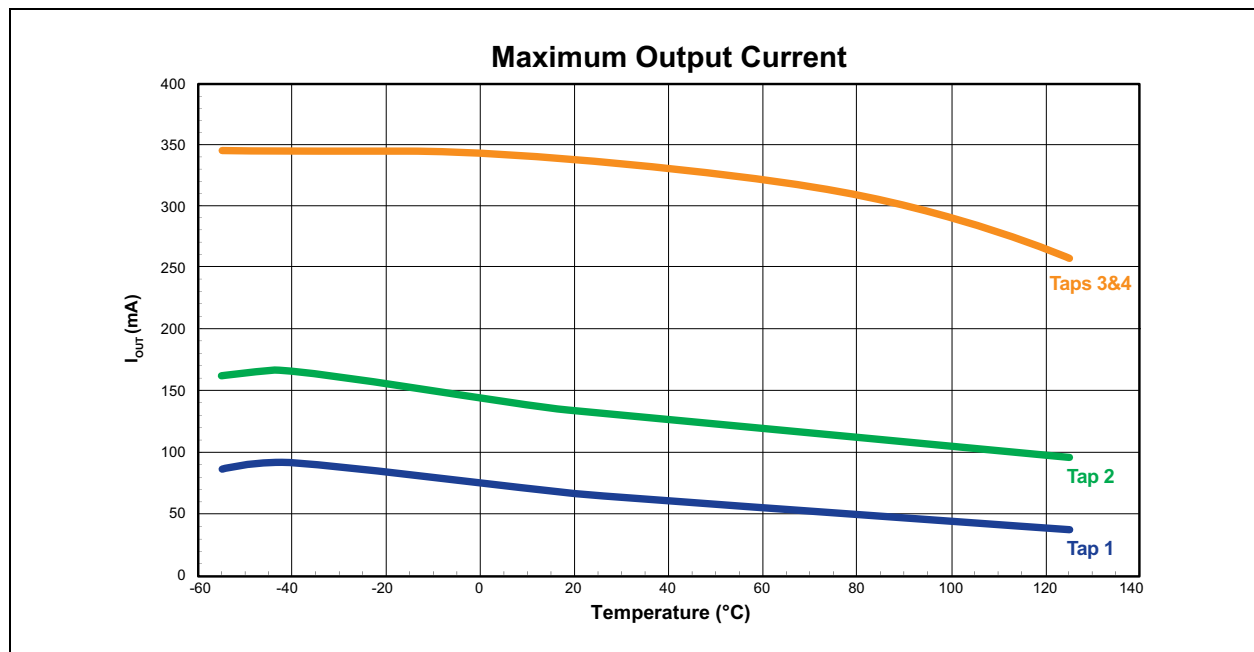

FIGURE 1-1: Output Current Thermal Characteristics.

CL8801

2.0 PIN DESCRIPTION

The details on the pins of CL8801 are listed in [Table 2-1](#). Refer to [Package Type](#) for the location of pins. The high-voltage pins are located on one side of the package and are arranged from lowest to highest voltage. Pin-to-pin voltage gradients are minimized.

TABLE 2-1: PIN FUNCTION TABLE

Pin Number	Pin Name	Description
1–8	GND	Circuit common. (Used for heat sink ground plane.)
9	SET1	Current sense for linear current regulators for each tap. Resistors on these pins set the tap currents.
10	NC	No internal connection
11	SET2	Current sense for linear current regulators for each tap. Resistors on these pins set the tap currents.
12	NC	No internal connection
13	SET3	Current sense for linear current regulators for each tap. Resistors on these pins set the tap currents.
14	NC	No internal connection
15	NC	No internal connection
16	NC	No internal connection
17	SET4	Current sense for linear current regulators for each tap. Resistors on these pins set the tap currents.
18	NC	No internal connection
19, 20	GND	Circuit common. (Used for heat sink ground plane.)
21	GND	Circuit common. (Used for heat sink ground plane.) Connect to bridge rectifier return.
22–26	GND	Circuit common. (Used for heat sink ground plane.)
27	TAP4	Current regulator outputs. Connect to taps along the LED string.
28	NC	No internal connection
29	TAP3	Current regulator outputs. Connect to taps along the LED string.
30	NC	No internal connection
31	TAP2	Current regulator outputs. Connect to taps along the LED string.
32	TAP1	Current regulator outputs. Connect to taps along the LED string.
33	BIAS	Provides bias for driver. Connect to rectified AC.
Underside Plate (GND)		For heat sinking purposes, it should be soldered to a 4 cm ² exposed copper area. It should also be electrically connected to circuit common (GND).

3.0 APPLICATION INFORMATION

3.1 Overview

Designing a driver to meet particular requirements may be a difficult task considering the 16 design variables: tap current (4), number of series-connected LEDs per segment (4), and the number of parallel-connected LEDs per segment (4). Manually selecting values will provide light, but the chosen values may be far from optimal with regard to efficiency, LED utilization and line regulation.

In addition to configuring the driver, several circuits may be employed to increase reliability, performance and cost. The following sections briefly describe these circuits. For additional information and design assistance, contact your nearest Microchip field applications engineer.

3.2 Transient Protection

The driver circuits have no need for capacitors that could otherwise absorb transient energy nor is there a need for EMI filters that would block transients. Therefore, the full burden of transient protection is borne by the protection circuit. (See [Figure 3-1.](#)) The two-stage approach in the following schematics provides 2.5 kV protection, both pulse and ring per EN 61000-4-5 and EN 61000-4-12, six hits each. (See [Figure 3-2.](#))

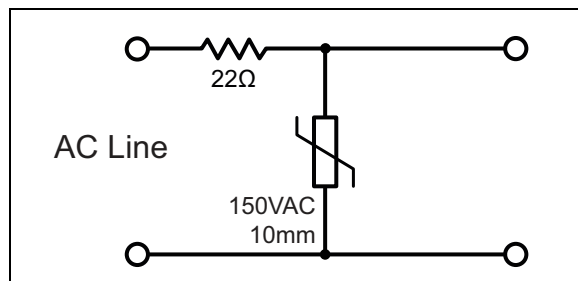

FIGURE 3-1: 100 VAC to 120 VAC Transient Protection.

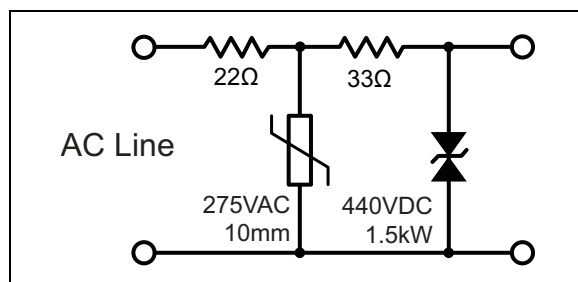

FIGURE 3-2: 230 VAC Transient Protection.

3.3 Zener Diode Substitution

Zener diodes may be substituted for LEDs in the bottom stages of the design. The last one or two stages of LEDs contribute little to the light output—they are mainly present to offload the adjacent upstream regulator at high line voltages to minimize losses. The advantages of Zener substitution include minimizing unlit LEDs at low line for better light uniformity, better line regulation at high line, fewer LEDs for lower cost and less PCB area and fewer board-to-board connections. Disadvantages include slightly reduced efficiency at high line and additional heat load on the driver board.

3.4 Phase Dimming

As with any light load, the LED lamp might not draw enough current to ensure proper dimmer operation. This is especially true for 230 VAC dimmers. Triodes for Alternating Current (TRIAC) used in dimmers require a minimum latching current when triggered to place the TRIAC in the latched-on state. Once latched, a minimum holding current is required to maintain the TRIAC in the ON state. Latching current is many times greater than the holding current and is the main concern with dimmer compatibility.

Higher latching current can be provided by a simple series RC network across the AC line. A short time constant provides a current spike at the turn-on edge. (See [Figure 3-3.](#))

Less common is inadequate holding current. The minimum dimmer holding current is typically 10 mA to 20 mA. Tap1 at 60 mA (maximum) exceeds the minimum.

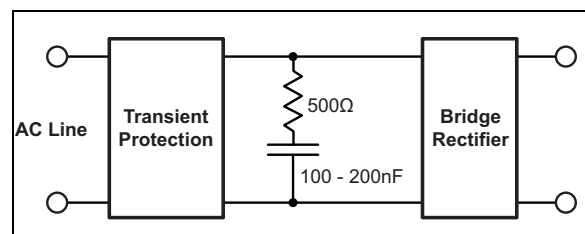

FIGURE 3-3: Phase Dimming.

3.5 Power Boost

Higher output power can be achieved by offloading a portion of the power dissipation from the CL8801 to external Field-Effect Transistors (FETs). The circuit in [Figure 3-4](#) drops most of the tap voltage across the FETs, thereby shifting the bulk of the dissipation to the FETs.

CL8801

3.6 Strobing

Twice per AC line cycle the line voltage crosses zero volts, during which time there is no light output.

The circuit in Figure 3-5 can provide 5% to 10% valley fill. It has little effect on input current wave shape (THD, PF) and efficiency. This circuit is intended to prevent the output from reaching zero. It will not significantly reduce output ripple.

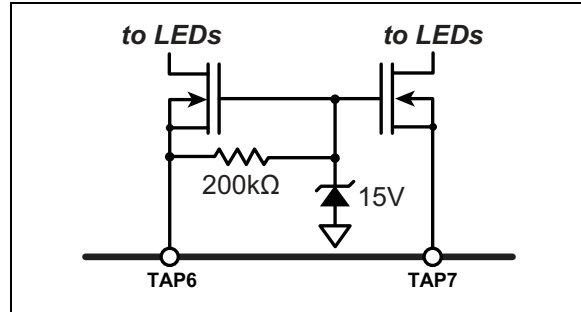

FIGURE 3-4: Power Boost.

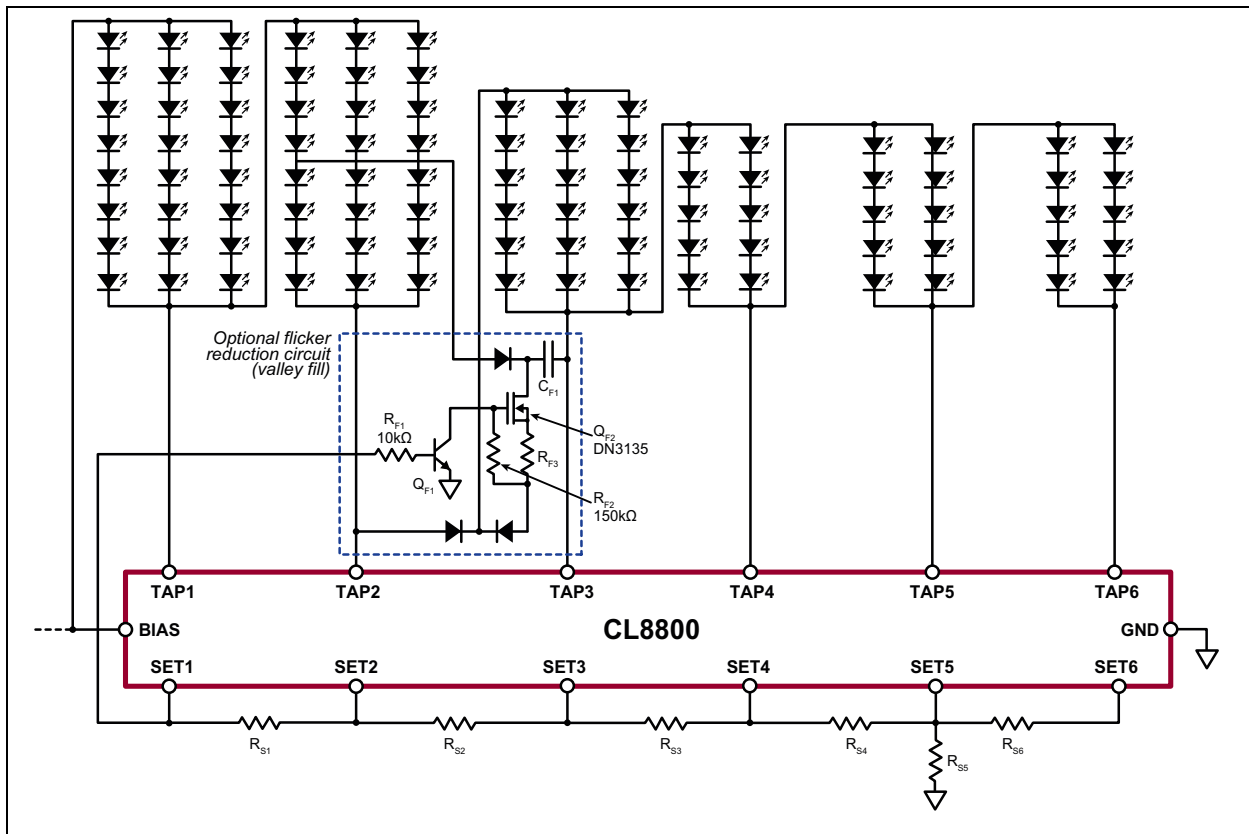
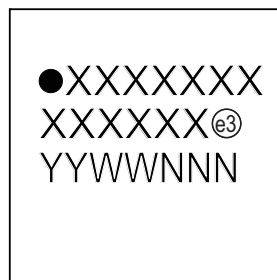

FIGURE 3-5: Valley Fill Circuit.

4.0 PACKAGING INFORMATION

4.1 Package Marking Information

33-lead QFN



Example

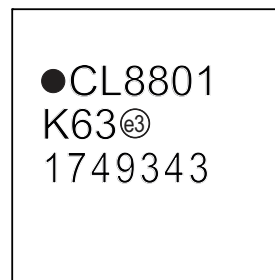

Legend:	XX...X	Product Code or Customer-specific information
	Y	Year code (last digit of calendar year)
	YY	Year code (last 2 digits of calendar year)
	WW	Week code (week of January 1 is week '01')
	NNN	Alphanumeric traceability code
	(e3)	Pb-free JEDEC® designator for Matte Tin (Sn)
	*	This package is Pb-free. The Pb-free JEDEC designator (e3) can be found on the outer packaging for this package.
Note:	In the event the full Microchip part number cannot be marked on one line, it will be carried over to the next line, thus limiting the number of available characters for product code or customer-specific information. Package may or may not include the corporate logo.	

33-Lead QFN Package Outline (K6)

6.00x6.00mm body, 1.00mm height (max), 0.50mm pitch

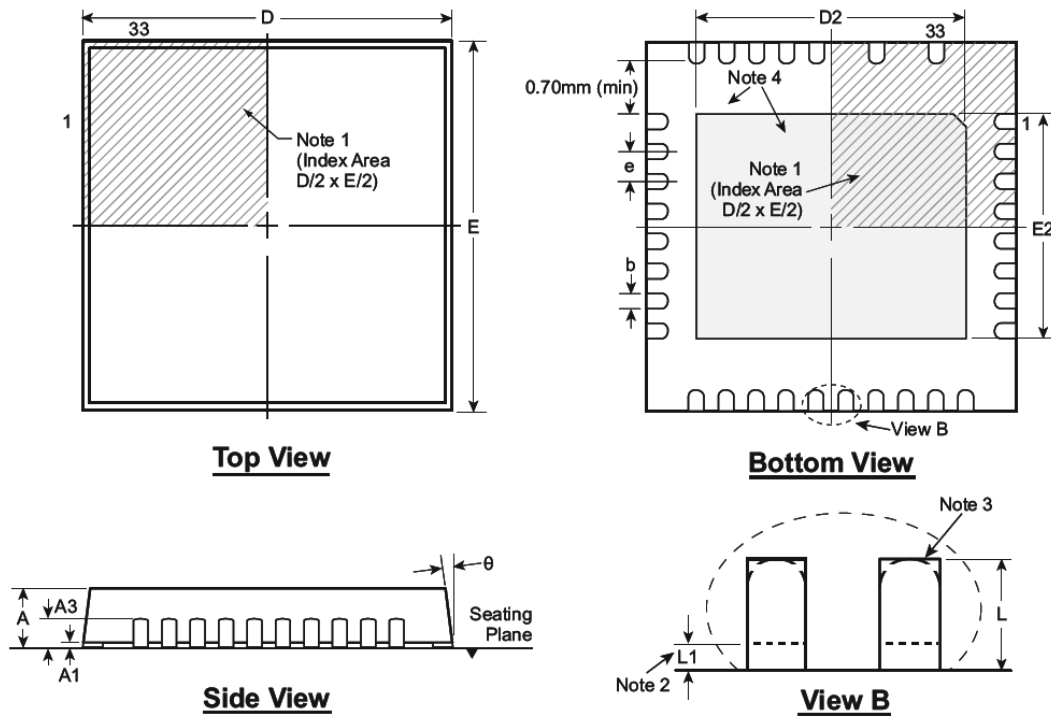

Note: For the most current package drawings, see the Microchip Packaging Specification at www.microchip.com/packaging.

Notes:

1. A Pin 1 identifier must be located in the index area indicated. The Pin 1 identifier can be: a molded mark/identifier; an embedded metal marker; or a printed indicator.
2. Depending on the method of manufacturing, a maximum of 0.15mm pullback (L1) may be present.
3. The inner tip of the lead may be either rounded or square.
4. There will be an exposed DAP. A minimum of 0.7mm spacing will be maintained between the leads and the DAP.

Symbol	A	A1	A3	b	D	D2	E	E2	e	L	L1	θ°	
Dimension (mm)	MIN	0.80	0.00	0.20 REF	0.18	5.85	4.00	5.85	3.60	0.50 BSC	0.30	0.00	0
	NOM	0.90	0.02		0.25	6.00	4.15	6.00	3.75		0.40	-	-
	MAX	1.00	0.05		0.30	6.15	4.25	6.15	3.85		0.50	0.15	14

Drawings not to scale.

APPENDIX A: REVISION HISTORY

Revision A (February 2017)

- Converted Supertex Doc# DSFP-CL8801 to Microchip DS20005601A
- Changed the quantity of the K6 M935 package from 2000/Reel to 3000/Reel
- Made minor text changes throughout the document

CL8801

PRODUCT IDENTIFICATION SYSTEM

To order or obtain information, e.g., on pricing or delivery, contact your local Microchip representative or sales office.

<u>PART NO.</u>	<u>XX</u>	-	<u>X</u>	-	<u>X</u>
Device	Package Options		Environmental		Media Type
Device:	CL8801	=	Sequential Linear LED Driver (Base Configuration: CL8801 + 4 Resistors + Diode Bridge)		
Package:	K6(3)	=	33-lead (6 x 6) QFN		
Environmental:	G	=	Lead (Pb)-free/RoHS-compliant Package		
Media Types:	(blank)	=	490/Tray for a K6 Package		
	M935	=	3000/Reel for a K6 Package		

Examples:

a) CL8801K63-G: Sequential Linear LED Driver (Base Configuration: CL8801 + 4 Resistors + Diode Bridge), 33-lead QFN Package, 490/Tray

b) CL8801K63-G-M935: Sequential Linear LED Driver (Base Configuration: CL8801 + 4 Resistors + Diode Bridge), 33-lead QFN Package, 3000/Reel

Note the following details of the code protection feature on Microchip devices:

- Microchip products meet the specification contained in their particular Microchip Data Sheet.
- Microchip believes that its family of products is one of the most secure families of its kind on the market today, when used in the intended manner and under normal conditions.
- There are dishonest and possibly illegal methods used to breach the code protection feature. All of these methods, to our knowledge, require using the Microchip products in a manner outside the operating specifications contained in Microchip's Data Sheets. Most likely, the person doing so is engaged in theft of intellectual property.
- Microchip is willing to work with the customer who is concerned about the integrity of their code.
- Neither Microchip nor any other semiconductor manufacturer can guarantee the security of their code. Code protection does not mean that we are guaranteeing the product as “unbreakable.”

Code protection is constantly evolving. We at Microchip are committed to continuously improving the code protection features of our products. Attempts to break Microchip's code protection feature may be a violation of the Digital Millennium Copyright Act. If such acts allow unauthorized access to your software or other copyrighted work, you may have a right to sue for relief under that Act.

Information contained in this publication regarding device applications and the like is provided only for your convenience and may be superseded by updates. It is your responsibility to ensure that your application meets with your specifications. MICROCHIP MAKES NO REPRESENTATIONS OR WARRANTIES OF ANY KIND WHETHER EXPRESS OR IMPLIED, WRITTEN OR ORAL, STATUTORY OR OTHERWISE, RELATED TO THE INFORMATION, INCLUDING BUT NOT LIMITED TO ITS CONDITION, QUALITY, PERFORMANCE, MERCHANTABILITY OR FITNESS FOR PURPOSE. Microchip disclaims all liability arising from this information and its use. Use of Microchip devices in life support and/or safety applications is entirely at the buyer's risk, and the buyer agrees to defend, indemnify and hold harmless Microchip from any and all damages, claims, suits, or expenses resulting from such use. No licenses are conveyed, implicitly or otherwise, under any Microchip intellectual property rights unless otherwise stated.

Microchip received ISO/TS-16949:2009 certification for its worldwide headquarters, design and wafer fabrication facilities in Chandler and Tempe, Arizona; Gresham, Oregon and design centers in California and India. The Company's quality system processes and procedures are for its PIC® MCUs and dsPIC® DSCs, KEELOQ® code hopping devices, Serial EEPROMs, microperipherals, nonvolatile memory and analog products. In addition, Microchip's quality system for the design and manufacture of development systems is ISO 9001:2000 certified.

**QUALITY MANAGEMENT SYSTEM
CERTIFIED BY DNV
= ISO/TS 16949 =**

Trademarks

The Microchip name and logo, the Microchip logo, AnyRate, AVR, AVR logo, AVR Freaks, BeaconThings, BitCloud, CryptoMemory, CryptoRF, dsPIC, FlashFlex, flexPWR, Heldo, JukeBlox, KEELOQ, KEELOQ logo, Klear, LANCheck, LINK MD, maXStylus, maXTouch, MediaLB, megaAVR, MOST, MOST logo, MPLAB, OptoLyzer, PIC, picoPower, PICSTART, PIC32 logo, Prochip Designer, QTouch, RightTouch, SAM-BA, SpyNIC, SST, SST Logo, SuperFlash, tinyAVR, UNI/O, and XMEGA are registered trademarks of Microchip Technology Incorporated in the U.S.A. and other countries.

ClockWorks, The Embedded Control Solutions Company, EtherSynch, Hyper Speed Control, HyperLight Load, IntelliMOS, mTouch, Precision Edge, and Quiet-Wire are registered trademarks of Microchip Technology Incorporated in the U.S.A.

Adjacent Key Suppression, AKS, Analog-for-the-Digital Age, Any Capacitor, AnyIn, AnyOut, BodyCom, chipKIT, chipKIT logo, CodeGuard, CryptoAuthentication, CryptoCompanion, CryptoController, dsPICDEM, dsPICDEM.net, Dynamic Average Matching, DAM, ECAN, EtherGREEN, In-Circuit Serial Programming, ICSP, Inter-Chip Connectivity, JitterBlocker, KlearNet, KlearNet logo, Mindi, MiWi, motorBench, MPASM, MPF, MPLAB Certified logo, MPLIB, MPLINK, MultiTRAK, NetDetach, Omniscient Code Generation, PICDEM, PICDEM.net, PICKit, PICTail, PureSilicon, QMatrix, RightTouch logo, REAL ICE, Ripple Blocker, SAM-ICE, Serial Quad I/O, SMART-I.S., SQI, SuperSwitcher, SuperSwitcher II, Total Endurance, TSHARC, USBCheck, VariSense, ViewSpan, WiperLock, Wireless DNA, and ZENA are trademarks of Microchip Technology Incorporated in the U.S.A. and other countries.

SQTP is a service mark of Microchip Technology Incorporated in the U.S.A.

Silicon Storage Technology is a registered trademark of Microchip Technology Inc. in other countries.

GestIC is a registered trademark of Microchip Technology Germany II GmbH & Co. KG, a subsidiary of Microchip Technology Inc., in other countries.

All other trademarks mentioned herein are property of their respective companies.

© 2017, Microchip Technology Incorporated, All Rights Reserved.
ISBN: 978-1-5224-1384-4



MICROCHIP

Worldwide Sales and Service

AMERICAS

Corporate Office
2355 West Chandler Blvd.
Chandler, AZ 85224-6199
Tel: 480-792-7200
Fax: 480-792-7277
Technical Support:
<http://www.microchip.com/support>
Web Address:
www.microchip.com

Atlanta
Duluth, GA
Tel: 678-957-9614
Fax: 678-957-1455

Austin, TX
Tel: 512-257-3370

Boston
Westborough, MA
Tel: 774-760-0087
Fax: 774-760-0088

Chicago
Itasca, IL
Tel: 630-285-0071
Fax: 630-285-0075

Dallas
Addison, TX
Tel: 972-818-7423
Fax: 972-818-2924

Detroit
Novi, MI
Tel: 248-848-4000

Houston, TX
Tel: 281-894-5983

Indianapolis
Noblesville, IN
Tel: 317-773-8323
Fax: 317-773-5453
Tel: 317-536-2380

Los Angeles
Mission Viejo, CA
Tel: 949-462-9523
Fax: 949-462-9608
Tel: 951-273-7800

Raleigh, NC
Tel: 919-844-7510

New York, NY
Tel: 631-435-6000

San Jose, CA
Tel: 408-735-9110
Tel: 408-436-4270

Canada - Toronto
Tel: 905-695-1980
Fax: 905-695-2078

ASIA/PACIFIC

Asia Pacific Office
Suites 3707-14, 37th Floor
Tower 6, The Gateway
Harbour City, Kowloon

Hong Kong
Tel: 852-2943-5100
Fax: 852-2401-3431

Australia - Sydney
Tel: 61-2-9868-6733
Fax: 61-2-9868-6755

China - Beijing
Tel: 86-10-8569-7000
Fax: 86-10-8528-2104

China - Chengdu
Tel: 86-28-8665-5511
Fax: 86-28-8665-7889

China - Chongqing
Tel: 86-23-8980-9588
Fax: 86-23-8980-9500

China - Dongguan
Tel: 86-769-8702-9880

China - Guangzhou
Tel: 86-20-8755-8029

China - Hangzhou
Tel: 86-571-8792-8115
Fax: 86-571-8792-8116

China - Hong Kong SAR
Tel: 852-2943-5100
Fax: 852-2401-3431

China - Nanjing
Tel: 86-25-8473-2460
Fax: 86-25-8473-2470

China - Qingdao
Tel: 86-532-8502-7355
Fax: 86-532-8502-7205

China - Shanghai
Tel: 86-21-3326-8000
Fax: 86-21-3326-8021

China - Shenyang
Tel: 86-24-2334-2829
Fax: 86-24-2334-2393

China - Shenzhen
Tel: 86-755-8864-2200
Fax: 86-755-8203-1760

China - Wuhan
Tel: 86-27-5980-5300
Fax: 86-27-5980-5118

China - Xian
Tel: 86-29-8833-7252
Fax: 86-29-8833-7256

ASIA/PACIFIC

China - Xiamen
Tel: 86-592-2388138
Fax: 86-592-2388130

China - Zhuhai
Tel: 86-756-3210040
Fax: 86-756-3210049

India - Bangalore
Tel: 91-80-3090-4444
Fax: 91-80-3090-4123

India - New Delhi
Tel: 91-11-4160-8631
Fax: 91-11-4160-8632

India - Pune
Tel: 91-20-3019-1500

Japan - Osaka
Tel: 81-6-6152-7160
Fax: 81-6-6152-9310

Japan - Tokyo
Tel: 81-3-6880-3770
Fax: 81-3-6880-3771

Korea - Daegu
Tel: 82-53-744-4301
Fax: 82-53-744-4302

Korea - Seoul
Tel: 82-2-554-7200
Fax: 82-2-558-5932 or
82-2-558-5934

Malaysia - Kuala Lumpur
Tel: 60-3-6201-9857
Fax: 60-3-6201-9859

Malaysia - Penang
Tel: 60-4-227-8870
Fax: 60-4-227-4068

Philippines - Manila
Tel: 63-2-634-9065
Fax: 63-2-634-9069

Singapore
Tel: 65-6334-8870
Fax: 65-6334-8850

Taiwan - Hsin Chu
Tel: 886-3-5778-366
Fax: 886-3-5770-955

Taiwan - Kaohsiung
Tel: 886-7-213-7830

Taiwan - Taipei
Tel: 886-2-2508-8600
Fax: 886-2-2508-0102

Thailand - Bangkok
Tel: 66-2-694-1351
Fax: 66-2-694-1350

EUROPE

Austria - Wels
Tel: 43-7242-2244-39
Fax: 43-7242-2244-393

Denmark - Copenhagen
Tel: 45-4450-2828
Fax: 45-4485-2829

Finland - Espoo
Tel: 358-9-4520-820

France - Paris
Tel: 33-1-69-53-63-20
Fax: 33-1-69-30-90-79

France - Saint Cloud
Tel: 33-1-30-60-70-00

Germany - Garching
Tel: 49-8931-9700

Germany - Haan
Tel: 49-2129-3766400

Germany - Heilbronn
Tel: 49-7131-67-3636

Germany - Karlsruhe
Tel: 49-721-625370

Germany - Munich
Tel: 49-89-627-144-0
Fax: 49-89-627-144-44

Germany - Rosenheim
Tel: 49-8031-354-560

Israel - Ra'anana
Tel: 972-9-744-7705

Italy - Milan
Tel: 39-0331-742611
Fax: 39-0331-466781

Italy - Padova
Tel: 39-049-7625286

Netherlands - Drunen
Tel: 31-416-690399
Fax: 31-416-690340

Norway - Trondheim
Tel: 47-7289-7561

Poland - Warsaw
Tel: 48-22-3325737

Romania - Bucharest
Tel: 40-21-407-87-50

Spain - Madrid
Tel: 34-91-708-08-90
Fax: 34-91-708-08-91

Sweden - Gothenberg
Tel: 46-31-704-60-40

Sweden - Stockholm
Tel: 46-8-5090-4654

UK - Wokingham
Tel: 44-118-921-5800
Fax: 44-118-921-5820