

THIS DRAWING IS UNPUBLISHED. RELEASED FOR PUBLICATION
 © COPYRIGHT - By - ALL RIGHTS RESERVED.

LOC		DIST		REVISIONS			
P	LTR	DESCRIPTION		DATE	DWN	APVD	
GP	00	V		REVISED PER ECO-15-010090	16JUL2015	AP	DG

D

C

B

A

D

C

B

A

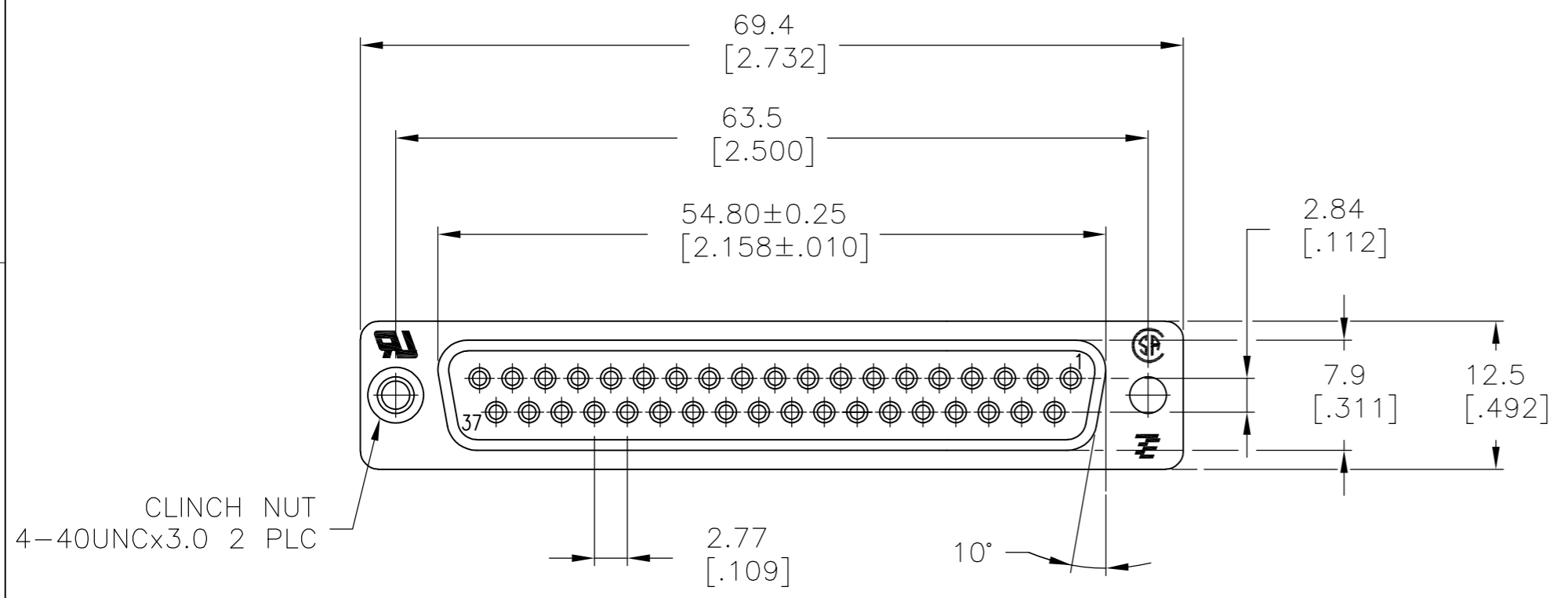

CLINCH NUT
 4-40UNCx3.0 2 PLC

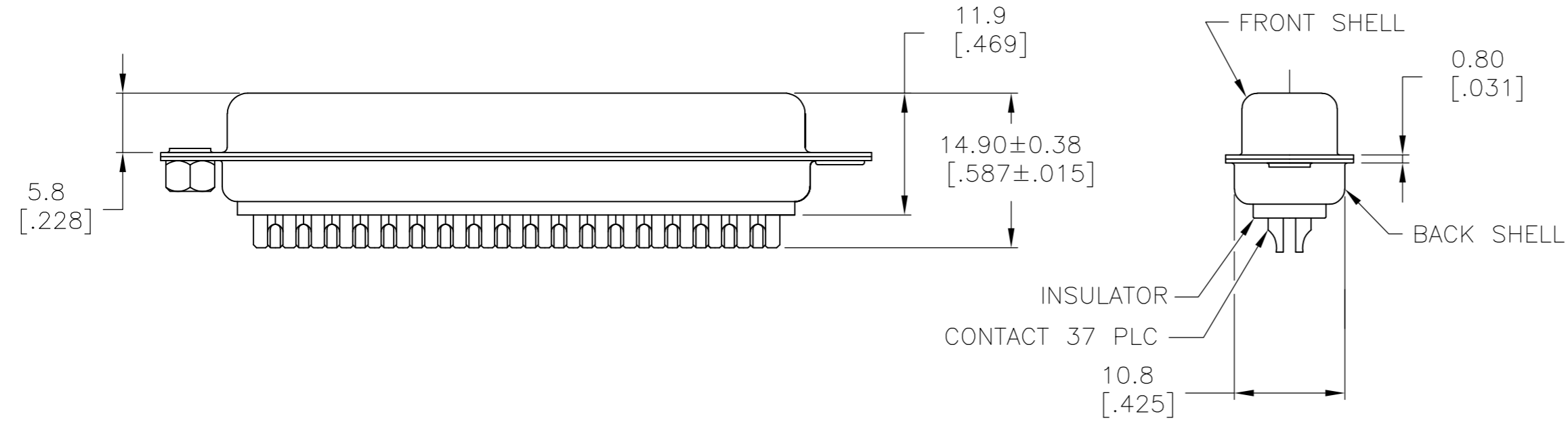

- 1 MATERIAL:
 FRONT INSULATOR: PBT, 30 %GF, UL94V-0, BLACK COLOR
 BACK INSULATOR: PBT, 30 %GF, UL94V-0, BLACK COLOR
 CONTACT: BRASS
 FRONT SHELL: STEEL
 BACK SHELL: STEEL
 CLINCH NUTS: BRASS
- 2 FINISH:
 CONTACT: GOLD PLATING 0.00002[.000008] MIN ON CONTACT AREA 0.00229 [.000090] MIN TIN-LEAD PLATING ALL OVER 0.00127[.000050] MIN NICKEL
- 3 CONTACT: GOLD PLATING 0.00076[.000030] MIN ON CONTACT AREA 0.00229 [.000090] MIN TIN-LEAD PLATING ALL OVER 0.00127[.000050] MIN NICKEL
- 4 SHELL: BRIGHT TIN 0.00241[.000095] MIN FULL SHELL
- 5 SHELL: BLUE ZINC: 0.00508[.000200] - 0.00762[.000300] OVER ENTIRE SHELL
- 6 CONTACT: GOLD PLATING 0.00002[.000008] MIN ON CONTACT AREA 0.00229 [.000090] MIN HOT DIPPED TIN-COPPER PLATING ALL OVER 0.00127[.000050] MIN NICKEL
- 7 CLINCH NUTS: NICKEL PLATING .00305-.00508[.000120-.000200]
- 8 SPECIFICATION
 ELECTRICAL CHARACTERISTICS: CURRENT RATING: 3 AMPERES
 DIELECTRIC WITHSTANDING VOLTAGE: AC 1000V r.m.s
 INSULATION RESISTANCE: 5000 MEGOHMS MINIMUM AT DC 500V
 CONTACT RESISTANCE: 10 MILLIOHMS MAXIMUM.
- 9 ROHS 2002/95/EC COMPLIANT
- 10 RECEPTACLE ASSEMBLY MATES WITH ANY 37 POSITION PLUG IN AMPLIMITE SERIES
- 11 SOLDER CUP WILL ACCOMMODATE 20 MAX AWG WIRE.
- 12 CONTACT: GOLD PLATING 0.00076[.000030] MIN ON CONTACT AREA 0.00229[.000090] MIN HOT DIPPED TIN-COPPER ALL OVER 0.00127[.000050] MIN NICKEL PLATING

REVISION	DESCRIPTION	DATE	BY	CHKD	APVD
1	STANDARD	NO	6	5	5-747917-4
2	STANDARD	YES	6	4	5-747917-6
3	STANDARD	NO	12	4	5-747917-5
4	STANDARD	NO	6	4	5-747917-2
5	STANDARD	NO	6	4	747917-7
6	STANDARD	YES	2	4	747917-6
7	STANDARD	NO	3	4	747917-5
8	STANDARD	NO	2	5	747917-4
9	STANDARD	NO	2	4	747917-2

THIS DRAWING IS A CONTROLLED DOCUMENT. DIMENSIONING AND TOLERANCING PER ASME Y14.5M-2009		DWN M. BINNER 04MAR03	TE Connectivity	
DIMENSIONS: mm [INCHES]		CHK R. BENDORF 05MAR03	RECEPTACLE ASSEMBLY, SOLDER CUP, SIZE 4, 37 POSN, HD-20, AMPLIMITE	
TOLERANCES UNLESS OTHERWISE SPECIFIED:		APVD R. BENDORF 05MAR03	NAME	RESTRICTED TO
0 PLC ± -	1 PLC ± 0.25	PRODUCT SPEC	SIZE	SCALE
2 PLC ± 0.13	3 PLC ± 0.05	APPLICATION SPEC	CAGE CODE	SHEET
4 PLC ± -	ANGLES ± 4°	WEIGHT	DRAWING NO	REV
MATERIAL	FINISH	CUSTOMER DRAWING	A2 00779	1 of 1
1	SEE TABLE	CLINCH NUTS	C=747917	2:1

747917