

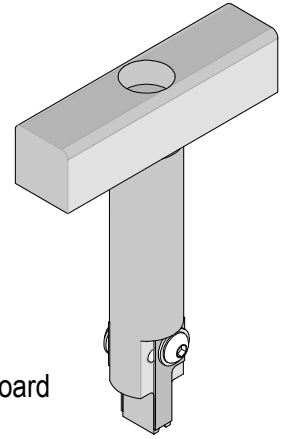

Heat Sink Hook Insertion Tool Tooling Specification Order No. 62100-6900



FEATURES

- The Heat Sink Insertion Tool is used for inserting a heat sink hook onto a printed circuit board (PCB).
- Retaining fingers on tool prevent HeatSink Hook from falling out of tool.

SCOPE

Products: Heat Sink Hooks 46548 Series. See Product List below for specific part numbers

Product List

The following is a partial list of the product order numbers and their specifications that this tool is designed to repair. Updates to this list are available on www.molex.com.

Terminal Series No.	Terminal Order No.		
46548	46548-0001	46548-0002	46548-0003
	46548-1001	46548-1002	46548-1003

OPERATION

Individual Heat Sink Hooks maybe inserted in a printed circuit board (PCB) using this tool. Follow the instructions below:

1. Hold the Heat Sink Hook by the prongs and place it into the slot at the tip of the Insertion Tool until it stops.
2. The solder tangs of the Heat Sink Hook should be touching the bottom of the push-in rod of the Insertion Tool, and centered between the retaining fingers. Make sure it is held between the fingers so it will not fall out during insertion into the PCB. See Figure 1.
3. Hold the Insertion Tool by the T-handle and align the hook prongs into the correct hole orientation in the PCB. The solder tangs should line up with the solder pads on the PCB. See drawing SD-46548-001 for more information.
4. Guide the Heat Sink Hook prongs into the holes of the PCB.

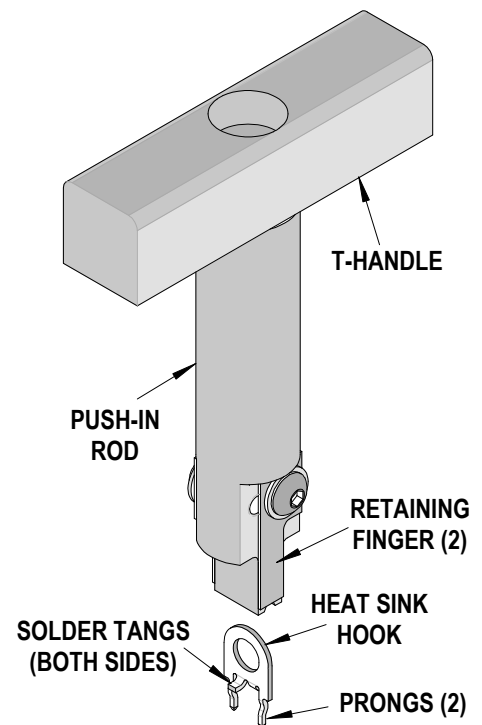

Figure 1

5. Continue pushing the hook until it is completely seated in the PCB. The hook is seated when the solder tangs are touching the solder pads of the PCB. The hook should snap into place. See Figure 2.
6. Pull the Insertion Tool straight up and remove.
7. Visually check the final seating of the Heat Sink Hook; the solder tangs should be touching the PCB.
8. If the HeatSink Hook needs to be removed (prior to soldering) the eye of the hook can be gripped with long-nose pliers. Pull the hook straight up.

Printed Circuit Board (PCB) Support

The Heat Sink Hook requires up to 10.4kg (23.0 lbs) of force to insert into the PCB. To prevent excessive PCB flexure and/or damage to the PCB, a support plate is strongly recommended directly beneath the Heat Sink hole pattern.

Due to the custom nature of every application, Molex does not offer any PCB support plate. The customer must furnish their own support plate.

When creating the PCB support plate, remember to allow clearance for the connector pins as they pass through the PCB thickness.

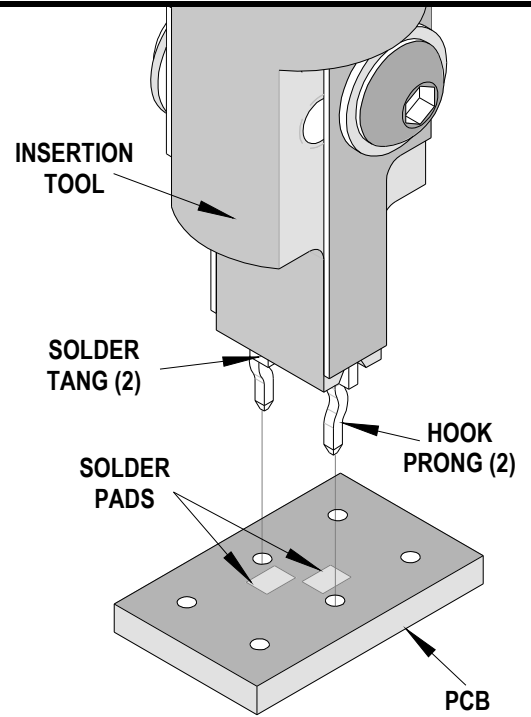

Figure 2

CAUTION: Molex application tooling specifications are valid only when used with Molex products and tooling.

Contact Information

For more information on Molex application tooling please contact Molex at 1-800-786-6539.

Parts List

Item	Order No	Description	Quantity
	62100-6900	Heat Sink Hook Insertion Tool	Figure 3
1	62100-6204	T Handle	1
2	62100-6901	Push-In Rod	1
3	62100-6902	Lifting Finger	2
Hardware			
4	N/A	M3 by 6 Long BHCS	2**
5	N/A	M5 by 16 Long SSS	1**
6	N/A	M3 Flat Washer	2**

** Available from an industrial supply company such as MSC (1-800-645-7270).

Assembly Drawing

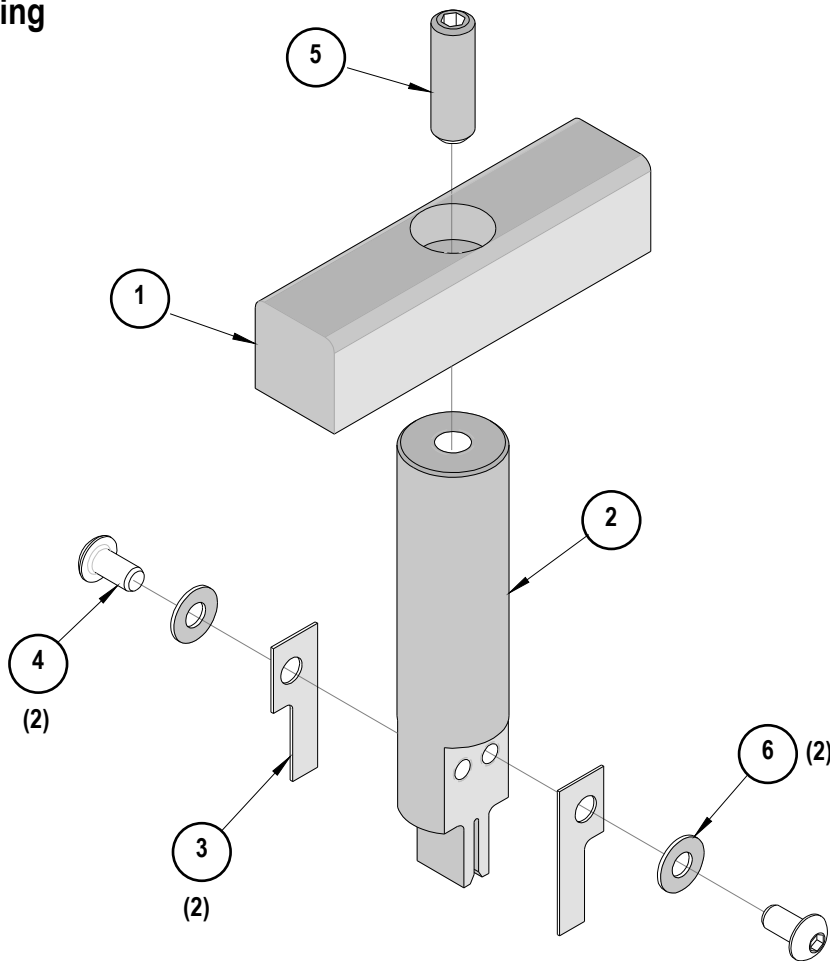

Figure 3

Americas Headquarters
 Lisle, Illinois 60532 U.S.A.
 1-800-78MOLEX
 amerinfo@molex.com

Far East North Headquarters
 Yamato, Kanagawa, Japan
 81-462-65-2324
 feninfo@molex.com

Far East South Headquarters
 Jurong, Singapore
 65-6-268-6868
 fesinfo@molex.com

European Headquarters
 Munich, Germany
 49-89-413092-0
 eurinfo@molex.com

Corporate Headquarters
 2222 Wellington Ct.
 Lisle, IL 60532 U.S.A.
 630-969-4550
 Fax: 630-969-1352

Visit our Web site at <http://www.molex.com>