

HAL[®] 2420, HAL 2425

High-Precision Programmable
Linear Hall-Effect Sensors with
Arbitrary Output Characteristics

Copyright, Warranty, and Limitation of Liability

The information and data contained in this document are believed to be accurate and reliable. The software and proprietary information contained therein may be protected by copyright, patent, trademark and/or other intellectual property rights of TDK-Micronas. All rights not expressly granted remain reserved by TDK-Micronas.

TDK-Micronas assumes no liability for errors and gives no warranty representation or guarantee regarding the suitability of its products for any particular purpose due to these specifications.

By this publication, TDK-Micronas does not assume responsibility for patent infringements or other rights of third parties which may result from its use. Commercial conditions, product availability and delivery are exclusively subject to the respective order confirmation.

Any information and data which may be provided in the document can and do vary in different applications, and actual performance may vary over time.

All operating parameters must be validated for each customer application by customers' technical experts. Any mention of target applications for our products is made without a claim for fit for purpose as this has to be checked at system level.

Any new issue of this document invalidates previous issues. TDK-Micronas reserves the right to review this document and to make changes to the document's content at any time without obligation to notify any person or entity of such revision or changes. For further advice please contact us directly.

Do not use our products in life-supporting systems, military, aviation, or aerospace applications! Unless explicitly agreed to otherwise in writing between the parties, TDK-Micronas' products are not designed, intended or authorized for use as components in systems intended for surgical implants into the body, or other applications intended to support or sustain life, or for any other application in which the failure of the product could create a situation where personal injury or death could occur.

No part of this publication may be reproduced, photocopied, stored on a retrieval system or transmitted without the express written consent of TDK-Micronas.

TDK-Micronas Trademarks

– HAL

Third-Party Trademarks

All other brand and product names or company names may be trademarks of their respective companies.

Contents

Page	Section	Title
4	1.	Introduction
5	1.1.	Features
6	1.2.	Major Applications
6	2.	Ordering Information
7	2.1.	Device-Specific Ordering Codes
8	3.	Functional Description
8	3.1.	General Function
10	3.2.	Signal path and Register Definition
10	3.2.1.	Signal path
10	3.2.2.	Register Definition
11	3.2.2.1.	RAM registers
15	3.2.2.2.	EEPROM register
19	3.2.2.3.	NVRAM Registers
20	3.2.2.4.	Setpoint linearization accuracy
21	3.3.	On-board Diagnostic features
21	3.4.	Calibration of the sensor
22	4.	Specifications
22	4.1.	Outline Dimensions
28	4.2.	Solderability, Welding, Assembly
28	4.3.	Pin Connections and Short Descriptions
29	4.4.	Physical Dimensions
29	4.4.1.	Dimensions of Sensitive Area
30	4.5.	Absolute Maximum Ratings
31	4.6.	Storage and Shelf Life
31	4.7.	Recommended Operating Conditions
32	4.8.	Characteristics
34	4.9.	Open-Circuit Detection
34	4.10.	Overvoltage and Undervoltage Detection
35	4.11.	Magnetic Characteristics
36	4.11.1.	Definition of Sensitivity Error ES
37	5.	Application Notes
37	5.1.	Application Circuit
37	5.2.	Use of two HAL 242x in Parallel
38	5.3.	Ambient Temperature
39	6.	Programming of the Sensor
39	6.1.	Programming Interface
41	6.2.	Programming Environment and Tools
41	6.3.	Programming Information
42	7.	Document History

High-Precision Programmable Linear Hall-Effect Sensors with Arbitrary Output Characteristics

Note Revision bars indicate significant changes to the previous edition.

1. Introduction

HAL 242x is a family of programmable linear Hall-effect sensors consisting of two members: the HAL 2420 and the HAL 2425.

Both devices are universal magnetic-field sensors with a linear output based on the Hall effect. Major characteristics like magnetic-field range, sensitivity, output quiescent voltage (output voltage at $B=0$ mT), and output voltage range are programmable in a non-volatile memory. The sensors have a ratiometric output characteristic, which means that the output voltage is proportional to the magnetic flux and the supply voltage. Additionally, both sensors offer wire-break detection.

The HAL 2425 offers 16 setpoints to change the output characteristics from linear to arbitrary or vice versa.

Table 1–1: HAL 242x family members

Device	Key Function
HAL 2420	2 Setpoints (calibration points)
HAL 2425	16 Setpoints

The HAL 242x features a temperature-compensated Hall plate with chopper offset compensation, an A/D converter, digital signal processing, a D/A converter with output driver, an EEPROM with redundancy and lock function for the calibration data, a serial interface for programming the EEPROM, and protection devices at all pins. The internal digital signal processing is of great benefit because analog offsets, temperature shifts, and mechanical stress do not degrade digital signals.

The easy programmability allows a 2-point calibration by adjusting the output signal directly to the input signal (like mechanical angle, distance, or current). Individual adjustment of each sensor during the final manufacturing process is possible. With this calibration procedure, the tolerances of the sensor, the magnet, and the mechanical positioning can be compensated in the final assembly.

In addition, the temperature compensation of the Hall IC can be fit to all common magnetic materials by programming first and second order temperature coefficients of the Hall sensor sensitivity.

It is also possible to compensate offset drift over temperature generated by the customer application with a first order temperature coefficient for the sensor offset. This enables operation over the full temperature range with high accuracy.

The calculation of the individual sensor characteristics and the programming of the EEPROM can easily be done with a PC and the application kit from TDK-Micronas.

The sensors are designed for hostile industrial and automotive applications and operate with typically 5 V supply voltage in the junction temperature range from $-40\text{ }^{\circ}\text{C}$ up to $170\text{ }^{\circ}\text{C}$. The HAL 242x is available in the very small leaded package TO92UT-1/-2 and in the SOIC8-1 package.

1.1. Features

- High-precision linear Hall-effect sensors with 12-bit analog output
- 16 setpoints for various output signal shapes (HAL 2425)
- Multiple customer programmable magnetic characteristics in a non-volatile memory with redundancy and lock function
- Programmable temperature compensation for sensitivity and offset
- Magnetic-field measurements in the range of $\pm 200\text{ mT}$
- Low output voltage drifts over temperature
- Active open-circuit (ground and supply line break detection) with $5\text{ k}\Omega$ pull-up and pull-down resistor, overvoltage and undervoltage detection
- Programmable clamping function
- Digital readout of temperature and magnetic-field information in calibration mode
- Programming and operation of multiple sensors at the same supply line
- Active detection of output short between two sensors
- High immunity against mechanical stress, ESD, EMC
- Operates from $T_J = -40\text{ }^{\circ}\text{C}$ up to $170\text{ }^{\circ}\text{C}$
- Operates from 4.5 V up to 5.5 V supply voltage in specification and functions up to 8.5 V
- Operates with static magnetic fields and dynamic magnetic fields up to 2 kHz
- Overvoltage and reverse-voltage protection at all pins
- Short-circuit protected push-pull output
- Qualified according to AEC-Q100

1.2. Major Applications

Due to the sensors' versatile programming characteristics and low temperature drifts, the HAL 242x is the optimal system solution for applications such as:

- Contactless potentiometers,
- Angle sensors (like throttle position, pedal position and EGR applications),
- Distance and linear movement measurements,
- Magnetic-field and current measurement.

2. Ordering Information

A Micronas device is available in a variety of delivery forms. They are distinguished by a specific ordering code:

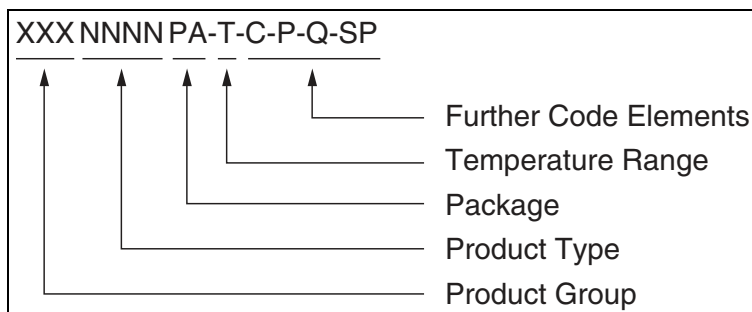

Fig. 2–1: Ordering Code Principle

For a detailed information, please refer to the brochure: “Micronas Sensors and Controllers: Ordering Codes, Packaging, Handling”.

2.1. Device-Specific Ordering Codes

HAL 242x is available in the following package and temperature variants.

Table 2–1: Available packages

Package Code (PA)	Package Type
UT	TO92UT-1/-2
DJ	SOIC8-1

Table 2–2: Available temperature ranges

Temperature Code (T)	Temperature Range
A	$T_J = -40\text{ °C to }+170\text{ °C}$

The relationship between ambient temperature (T_A) and junction temperature (T_J) is explained in Section 5.4. on page 29.

For available variants for Configuration (C), Packaging (P), Quantity (Q), and Special Procedure (SP) please contact TDK-Micronas.

Table 2–3: Available ordering codes and corresponding package marking

Available Ordering Codes	Package Marking
HAL2420UT-A-[C-P-Q-SP]	2420A
HAL2420DJ-A-[C-P-Q-SP]	2420A
HAL2425UT-A-[C-P-Q-SP]	2425A
HAL2425DJ-A-[C-P-Q-SP]	2425A

3. Functional Description

3.1. General Function

The HAL 242x is a monolithic integrated circuit which provides an output voltage proportional to the magnetic flux through the Hall plate and proportional to the supply voltage (ratiometric behavior).

The external magnetic-field component perpendicular to the branded side of the package generates a Hall voltage. The Hall IC is sensitive to magnetic north and south polarity. This voltage is converted to a digital value, processed in the Digital Signal Processing Unit (DSP) according to the settings of the EEPROM registers, converted back to an analog voltage with ratiometric behavior, and buffered by a push-pull output transistor stage.

The setting of a LOCK bit disables the programming of the EEPROM memory for all time. This bit cannot be reset by the customer.

As long as the LOCK bit is not set, the output characteristic can be adjusted by programming the EEPROM registers. The IC is addressed by modulating the output voltage.

In the supply voltage range from 4.5 V up to 5.5 V, the sensor generates an analog output voltage. After detecting a command, the sensor reads or writes the memory and answers with a digital signal on the output pin. The analog output is switched off during the communication. Several sensors in parallel to the same supply and ground line can be programmed individually. The selection of each sensor is done via its output pin.

The open-circuit detection provides a defined output voltage if the V_{SUP} or GND line is broken.

Internal temperature compensation circuitry and the spinning-current offset compensation enables operation over the full temperature range with minimal changes in accuracy and high offset stability. The circuitry also reduces offset shifts due to mechanical stress from the package. The non-volatile memory consists of redundant EEPROM cells. In addition, the sensor IC is equipped with devices for overvoltage and reverse-voltage protection at all pins.

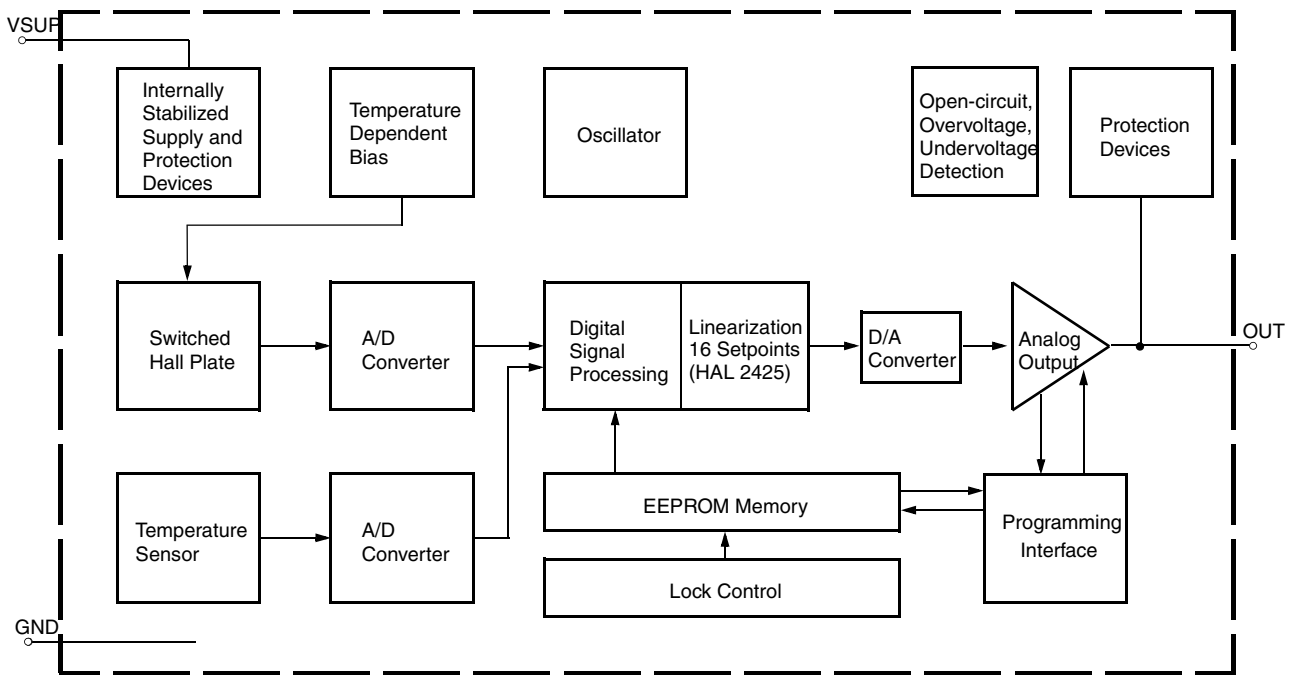

Fig. 3–1: HAL 242x block diagram

3.2. Signal path and Register Definition

3.2.1. Signal path

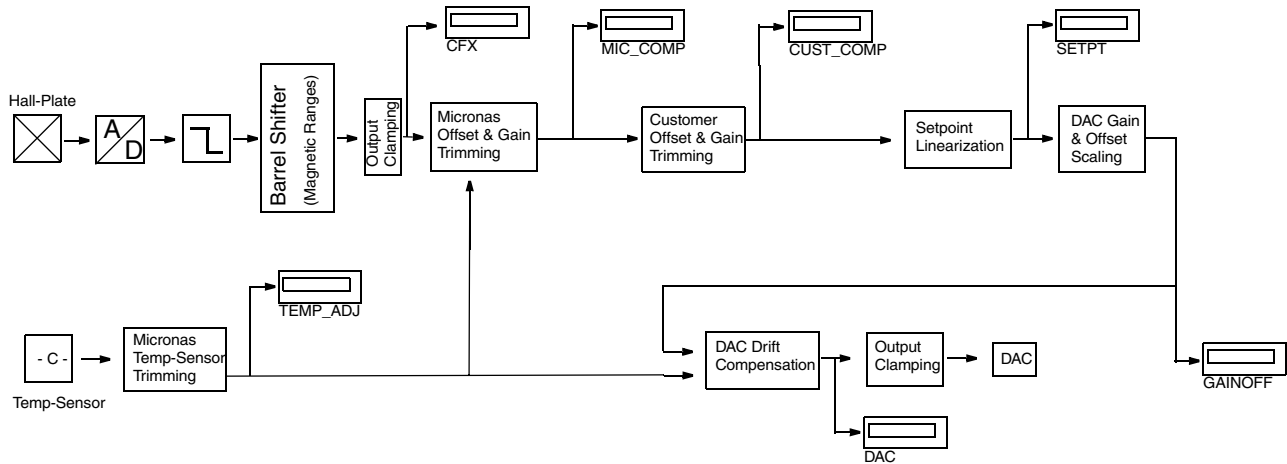

Fig. 3–2: Signal path of HAL 242x

3.2.2. Register Definition

The DSP is the major part of this sensor and performs the signal conditioning. The parameters for the DSP are stored in the EEPROM registers. The details are shown in Fig. 3–2.

Terminology:

GAIN: Name of the register or register value

Gain: Name of the parameter

The sensors signal path contains two kinds of registers. Registers that are readout only (RAM) and programmable registers (EEPROM & NVRAM). The RAM registers contain measurement data at certain positions of the signal path and the EEPROM registers have influence on the sensors signal processing.

3.2.2.1.RAM registers

TEMP_ADJ

The TEMP_ADJ register contains the calibrated temperature sensor information. TEMP_ADJ can be used for the sensor calibration over temperature. This register has a length of 16 bit and it is two's-complemented coded. Therefore the register value can vary between $-32768 \dots 32767$.

CFX

The CFX register represents the magnetic-field information directly after A/D conversion, decimation filter and magnetic range (barrel shifter) selection. The register content is not temperature compensated. The temperature variation of this register is specified in Section 4.11. on page 35 by the parameter RANGE_{ABS}.

Note

During application design, it must be taken into consideration that CFX should never overflow in the operational range of the specific application and especially over the full temperature range. In case of a potential overflow the barrels shifter should be switched to the next higher range.

This register has a length of 16 bit and it is two's-complemented coded. Therefore the register value can vary between $-32768 \dots 32767$. CFX register values will increase for positive magnetic fields (south pole) on the branded side of the package (positive CFX values) and it will decrease with negative magnetic-field polarity.

MIC_COMP

The MIC_COMP register is representing the magnetic-field information directly after the Micronas temperature trimming. The register content is temperature compensated and has a typical gain drift over temperature of 0 ppm/k. Also the offset and its drift over temperature is typically zero. The register has a length of 16 bit and it is two's-complemented coded. Therefore the register value can vary between $-32768 \dots 32767$.

CUST_COMP

The CUST_COMP register is representing the magnetic-field information after the customer temperature trimming. For HAL 242x it is possible to set a customer specific gain of second order over temperature as well as a customer specific offset of first order over temperature. The customer gain and offset can be set with the EEPROM registers TCCO0, TCCO1 for offset and TCCG0 ... TCCG2 for gain. Details of these registers are described on the following pages.

The register has a length of 16 bit and it is two's-complemented coded. Therefore the register value can vary between $-32768 \dots 32767$.

SETPT

The SETPT register offers the possibility to read the magnetic-field information after the linearization of the magnetic-field information with 16 setpoints. This information is also required for the correct setting of the sensors DAC GAIN and OFFSET in the following block.

The register has a length of 16 bit and it is two's-complemented coded. Therefore the register value can vary between $-32768 \dots 32767$.

GAINOFF

The GAINOFF register offers the possibility to read the magnetic-field information after the DAC GAIN and OFFSET scaling.

This register has a length of 16 bit and it is two's-complemented coded. Therefore the register value can vary between $-32768 \dots 32767$.

DAC

The DAC register offers the possibility to read the magnetic-field information at the end of the complete signal path. The value of this register is then converted into an analog output voltage.

The register has a length of 16 bit and it is two's-complemented coded. Therefore the register value can vary between $-32768 \dots 32767$.

MIC_ID1 and MIC_ID2

The two registers MIC_ID1 and MIC_ID2 are used by TDK-Micronas to store production information like, wafer number, die position on wafer, production lot, etc. Both registers have a length of 16 bit each and are readout only.

DIAGNOSIS

The DIAGNOSIS register enables the customer to identify certain failures detected by the sensor. HAL 242x performs certain self tests during power-up of the sensor and also during normal operation. The result of these self tests is stored in the DIAGNOSIS register. DIAGNOSIS register is a 16 bit register.

Bit No.	Function	Description
15:6	None	Reserved
5	State Machine (DSP) Self-test	This bit is set to 1 in case that the state machine self-test fails. (continuously running)
4	EEPROM Self-test	This bit is set to 1 in case that the EEPROM self-test fails. (Performed during power-up only)
3	ROM Check	This bit is set to 1 in case that ROM parity check fails. (continuously running)
2	Adder overflow	This bit is set to 1 in case that an overflow occurs during calculation of the Micronas temperature compensation
1:0	None	Reserved

Details on the sensor self-tests can be found in Section 3.3. on page 21.

PROG_DIAGNOSIS

The PROG_DIAGNOSIS register enables the customer to identify errors occurring during programming and writing of the EEPROM or NVRAM memory. The customer must either check the status of this register after each write or program command or alternatively the second acknowledge. Please check the Programming Guide for HAL 242x.

The PROG_DIAGNOSIS register is a 16 bit register. The following table shows the different bits indicating certain errors possibilities.

Bit No.	Function	Description
15:11	None	Reserved
10	Charge Pump Error	This bit is set to 1 in case that the internal programming voltage was to low
9	Voltage Error during Program/Erase	This bit is set to 1 in case that the internal supply voltage was to low during program or erase
8	NVRAM Error	This bit is set to 1 in case that the programming of the NVRAM failed
7:0	Memory Programming	For further information please refer to the Programming Guide for HAL 242x

3.2.2.2.EEPROM register

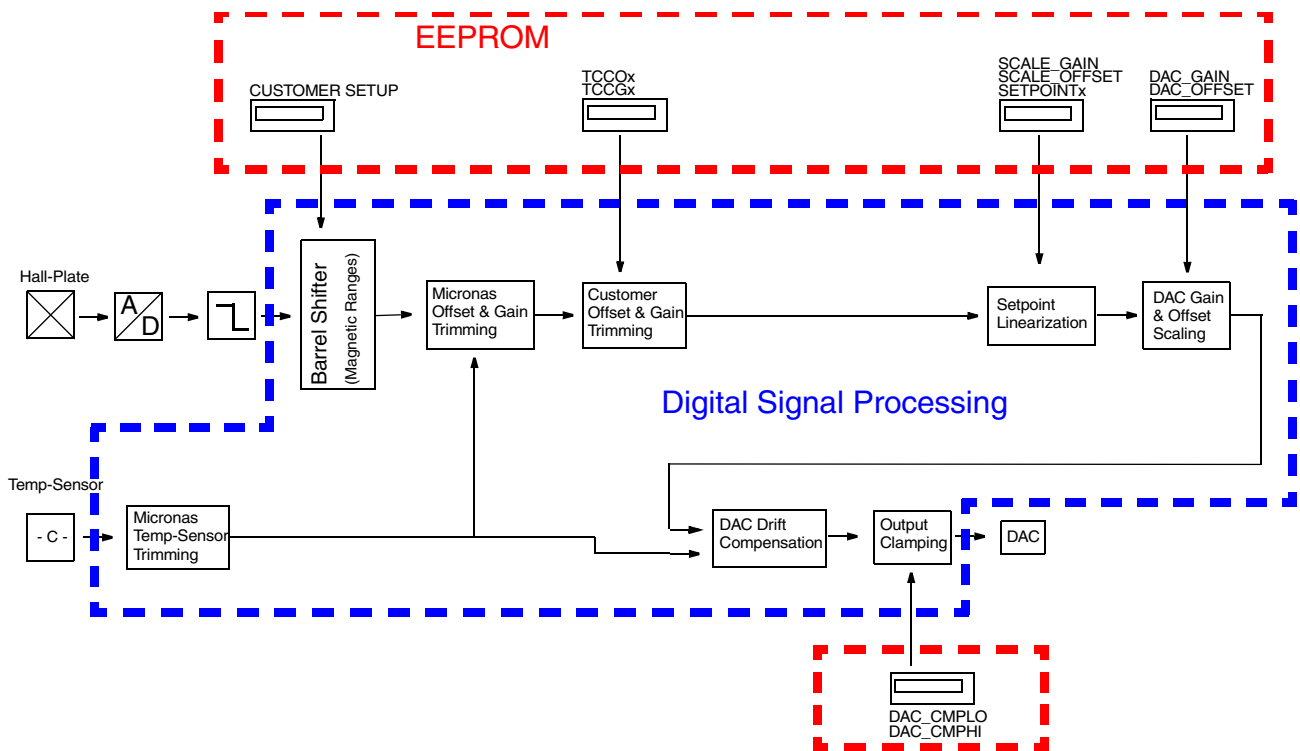

Fig. 3–3: Details of EEPROM and Digital Signal Processing

CUST_ID1 and CUST_ID2

The two registers CUST_ID1 and CUST_ID2 can be used to store customer information. Both registers have a length of 16 bit each.

Barrel Shifter (Magnetic ranges)

The signal path of HAL 242x contains a Barrel Shifter to emulate magnetic ranges. The customer can select between different magnetic ranges by changing the Barrel shifter setting. After decimation filter the signal path has a word length of 22 bit. The Barrel Shifter selects 16 bit out of the available 22 bit.

Note

In case that the external field exceeds the magnetic-field range the CFX register will be clamped either to -32768 or 32767 depending on the sign of the magnetic field.

Table 3–1: Relation between Barrel Shifter setting and emulated magnetic range

BARREL SHIFTER	Used bits	Typ. magnetic range
0	22...7	not used
1	21...6	± 200 mT
2	20...5	± 100 mT
3	19...4	± 50 mT
4	18...3	± 25 mT
5	17...2	± 12 mT
6	16...1	± 6 mT

The Barrel Shifter bits are part of the CUSTOMER SETUP register (bits 14...12). The CUSTOMER SETUP register is described on the following pages.

Magnetic Sensitivity TCCG

The TCCG (Sensitivity) registers (TCCG0 ... TCCG2) contain the customer setting for the multiplier in the DSP. The multiplication factor is a second order polynomial of the temperature.

All three polynomial coefficients have a bit length of 16 bit and they are two's-complemented coded. Therefore the register values can vary between $-32768 \dots 32767$. In case that the target polynomial is based on normalized values, then each coefficient can vary between $-1 \dots +1$. To store each coefficient into the EEPROM it is necessary to multiply the normalized coefficients with 32768.

Example:

$$- \text{Tccg0} = 0.5102 \Rightarrow \text{TCCG0} = 16719$$

$$- \text{Tccg1} = -0.0163 \Rightarrow \text{TCCG1} = -536$$

$$- \text{Tccg2} = 0.0144 \Rightarrow \text{TCCG2} = 471$$

In case that the polynomial was calculated based on not normalized values of TEMP_ADJ and MIC_COMP, then it is not necessary to multiply the polynomial coefficients with a factor of 32768.

Magnetic Offset TCCO

The TCCO (Offset) registers (TCCO0 and TCCO1) contain the parameters for the adder in the DSP of the sensor. The added value is a first order polynomial of the temperature.

Both polynomial coefficients have a bit length of 16 bit and they are two's-complemented coded. Therefore the register values can vary between $-32768 \dots 32767$.

In case that the target polynomial is based on normalized values, then each coefficient can vary between $-1 \dots +1$. To store each coefficient into the EEPROM it is necessary to multiply the normalized coefficients with 32768.

In case that the polynomial was calculated based on not normalized values of TEMP_ADJ and MIC_COMP, then it is not necessary to multiply the polynomial coefficients.

HAL 2425 features a linearization function based on 16 setpoints. The setpoint linearization in general allows to linearize a given output characteristic by applying the inverse compensation curve.

Each of the 16 setpoints (SETPT) registers have a length of 16 bit. The setpoints have to be computed and stored in a differential way. This means that if all setpoints are set to 0, then the linearization is set to neutral and a linear curve is used.

Sensitivity and Offset Scaling before setpoint linearization SCALE_GAIN/ SCALE_OFFSET

The setpoint linearization uses the full 16 bit number range 0...32767 (only positive values possible). So the signal path should be properly scaled for optimal usage of all 16 setpoints.

For optimum usage of the number range an additional scaling stage is added in front of the set point algorithm. The setpoint algorithm allows positive input numbers only.

The input scaling for the linearization stage is done with the EEPROM registers SCALE_GAIN and SCALE_OFFSET. The register content is calculated based on the calibration angles. Both registers have a bit length of 16 bit and are two's-complemented coded.

Analog output signal scaling with DAC_GAIN/DAC_OFFSET

The required output voltage range of the analog output is defined by the registers DAC_GAIN (Gain of the output) and DAC_OFFSET (Offset of the output signal). Both register values can be calculated based on the angular range and the required output voltage range. They have a bit length of 16 bit and are two's-complemented coded.

Clamping Levels

The clamping levels DAC_CMPHI and DAC_CMPLO define the maximum and minimum output voltage of the analog output. The clamping levels can be used to define the diagnosis band for the sensor output. Both registers have a bit length of 16 bit and are two's-complemented coded. Both clamping levels can have values between 0% and 100% of V_{SUP} .

3.2.2.3.NVRAM Registers

Customer Setup

The CUST_SETUP register is a 16 bit register that enables the customer to activate various functions of the sensor like, customer burn-in mode, diagnosis modes, functionality mode, customer lock, etc.

Table 3–2: Functions in CUST_SETUP register

Bit No.	Function	Description
15	None	Reserved
14:12	Barrel Shifter	Magnetic Range (see Section Table 3–1: on page 16)
11:10	None	Reserved
9:8	Output Short Detection	0: Disabled 1: High & low side over current detection -> OUT = V _{SUP} in error case 2: High & low side over current detection -> OUT = GND in error case 3: Low side over current detection -> OUT = Tristate in error case
7:6	None	Reserved
5	Functionality Mode	1: Normal
4	Communication Mode (POUT)	Communication via output pin 0: Disabled 1: Enabled
3	Overvoltage Detection	0: Overvoltage detection active 1: Overvoltage detection disabled
2	Diagnosis Latch	Latching of diagnosis bits 0: No latching 1: Latched till next POR (power-on reset)
1	Diagnosis	0: Diagnosis errors force output to error band (V _{SUP}) 1: Diagnosis errors do not force output to error band (V _{SUP})
0	Customer Lock	Bit must be set to 1 to lock the sensor memory

3.2.2.4. Setpoint linearization accuracy

The set point linearization in general allows to linearize a given output characteristic by applying the inverse compensation curve.

For this purpose the compensation curve will be divided into 16 segments with equal distance. Each segment is defined by two setpoints, which are stored in EEPROM. Within the interval, the output is calculated by linear interpolation according to the position within the interval.

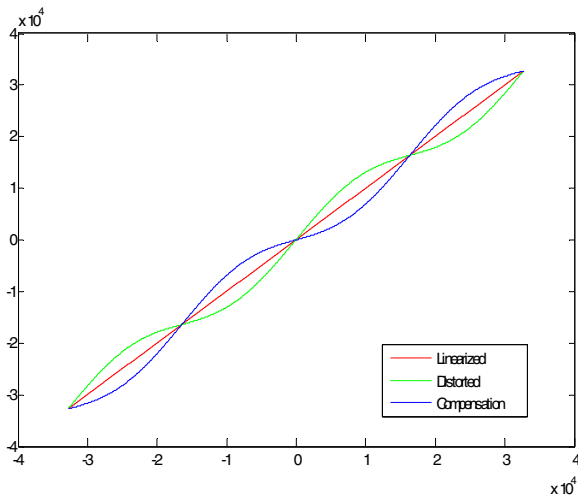

Fig. 3–4: Linearization - Principle

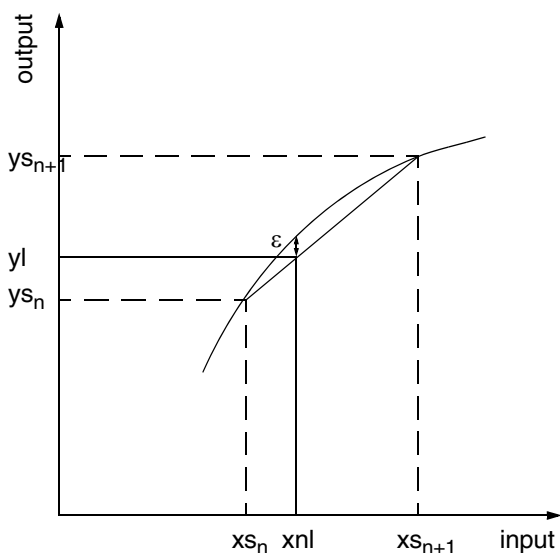

Fig. 3–5: Linearization - Detail

- xnl: non linear distorted input value
- yl: linearized value
- ϵ : remaining error

The constraint of the linearization is that the input characteristic has to be a monotonic function. In addition to that it is recommended that the input does not have a saddle point or inflection point, i.e. regions where the input is nearly constant. This would require a high density of set points

3.3. On-board Diagnostic features

The HAL 242x features two groups of diagnostic functions. The first group contains basic functions that are always active. The second group can be activated by the customer and contains supervision and self-tests related to the signal path and sensor memory.

Diagnostic features that are always active:

- Wire break detection for supply and ground line
- Undervoltage detection
- Thermal supervision of output stage (overcurrent, short circuit, etc.)

Diagnostic features that can be activated by customer:

- Overvoltage detection
- EEPROM self-test at power-on
- Continuous ROM parity check
- Continuous state machine self-test
- Adder overflow

The sensor indicates a fault immediately by switching the output signal to the upper diagnosis level (max. V_{out}) in case that the diagnostic mode is activated by the customer. The sensor switches the output to tristate if an over temperature is detected by the thermal supervision. The sensor switches the output to ground in case of a V_{SUP} wire break.

3.4. Calibration of the sensor

For calibration in the system environment, the application kit from TDK-Micronas is recommended. It contains the hardware for the generation of the serial telegram for programming (HAL-APB V1.5) and the corresponding LabVIEW™ based programming environment for the input of the register values.

For the individual calibration of each sensor in the customer application, a two point calibration is recommended.

A detailed description of the calibration software, calibration algorithm, programming sequences and register value calculation can be found in the Application Note “HAL 242x Programming Guide”.

4. Specifications

4.1. Outline Dimensions

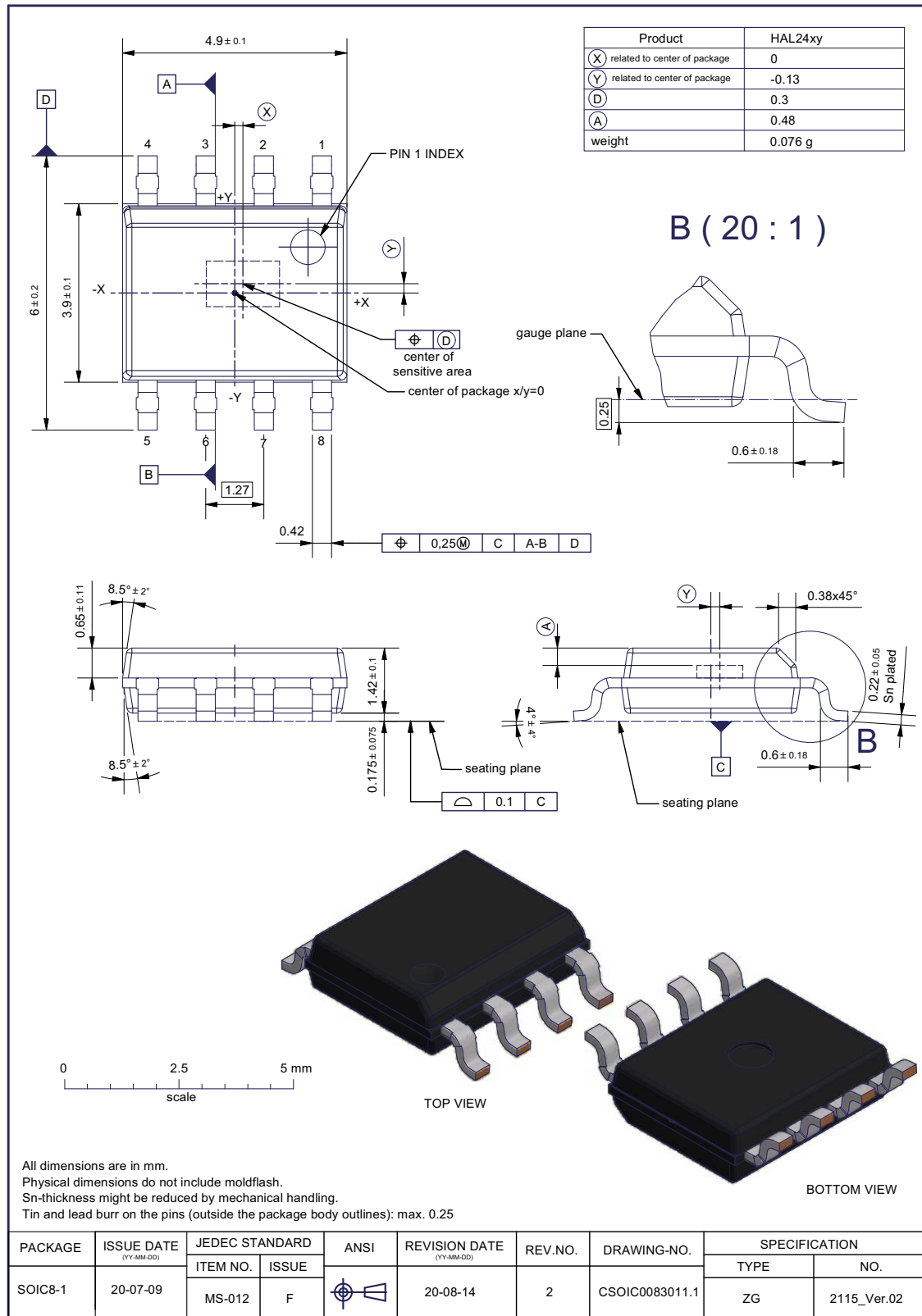

All dimensions are in mm.
 Physical dimensions do not include moldflash.
 Sn-thickness might be reduced by mechanical handling.
 Tin and lead burr on the pins (outside the package body outlines): max. 0.25

Fig. 4-1:
SOIC8-1: Plastic Small Outline IC package, 8 leads, gullwing bent, 150 mil
 Ordering code: DJ

© Copyright 2018 TDK-Micronas GmbH, all rights reserved

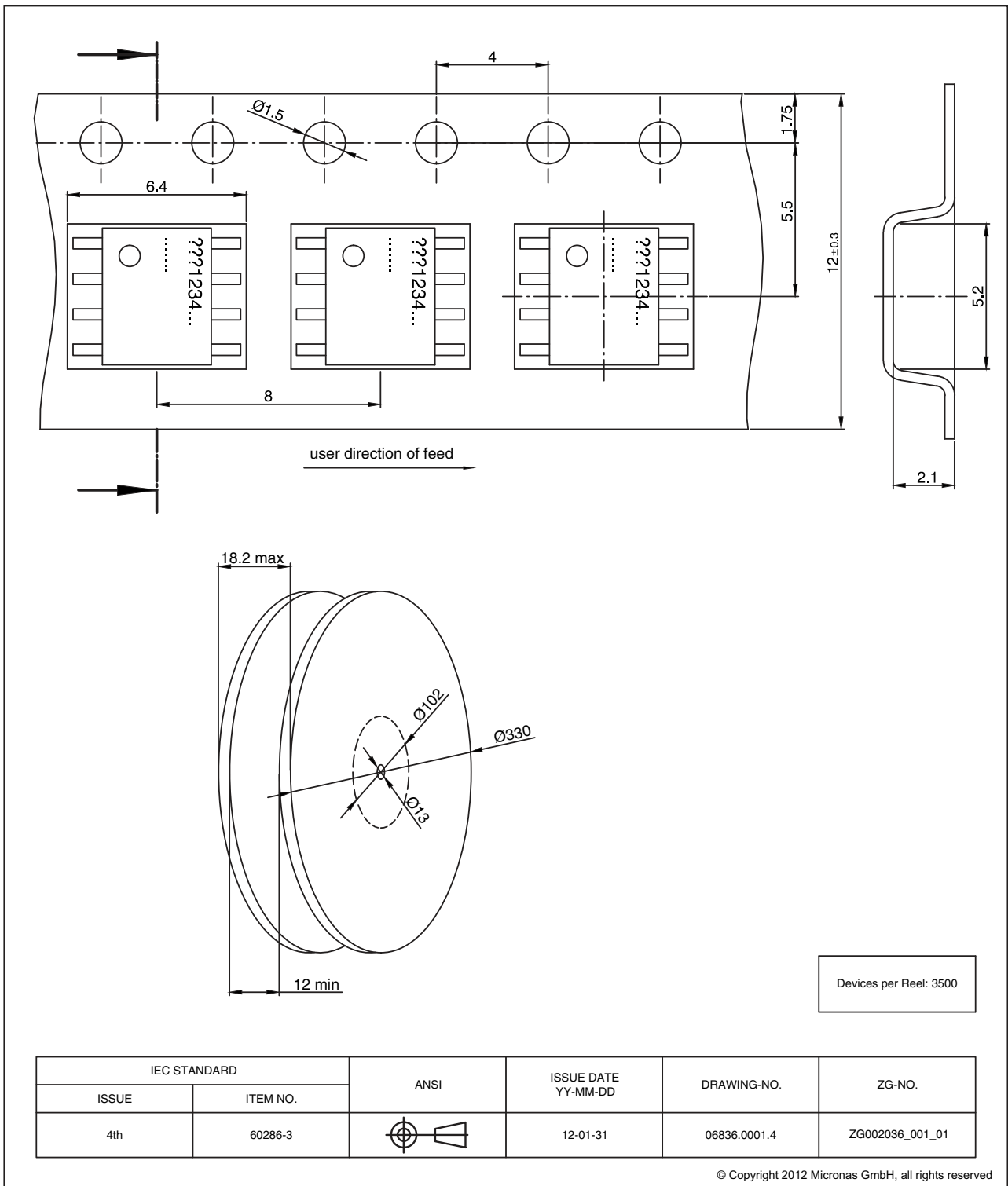

Fig. 4–2:
SOIC8: Tape and Reel Finishing

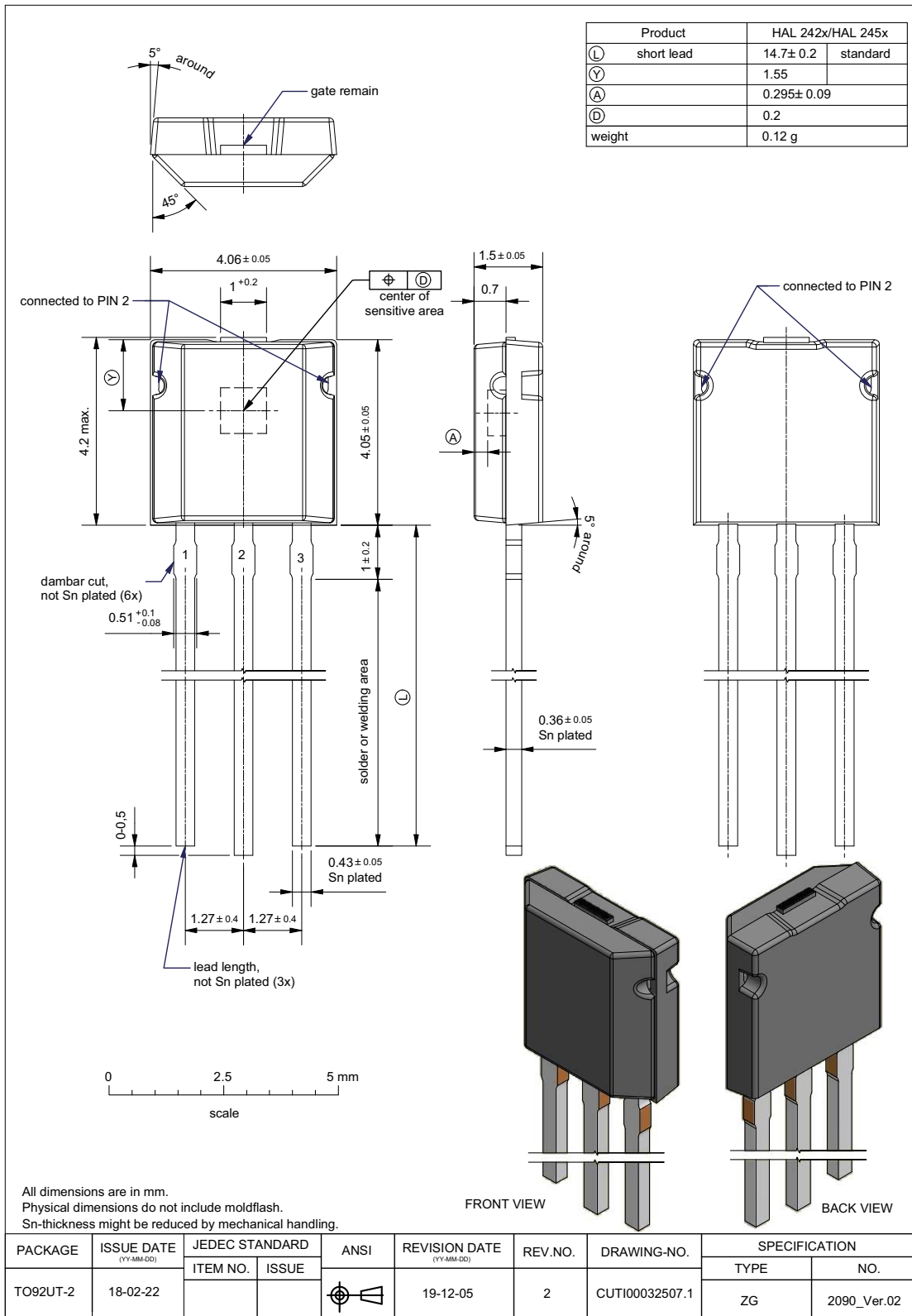

Fig. 4-3:
TO92UT-2 Plastic Transistor Standard UT package, 3 leads, non-spread

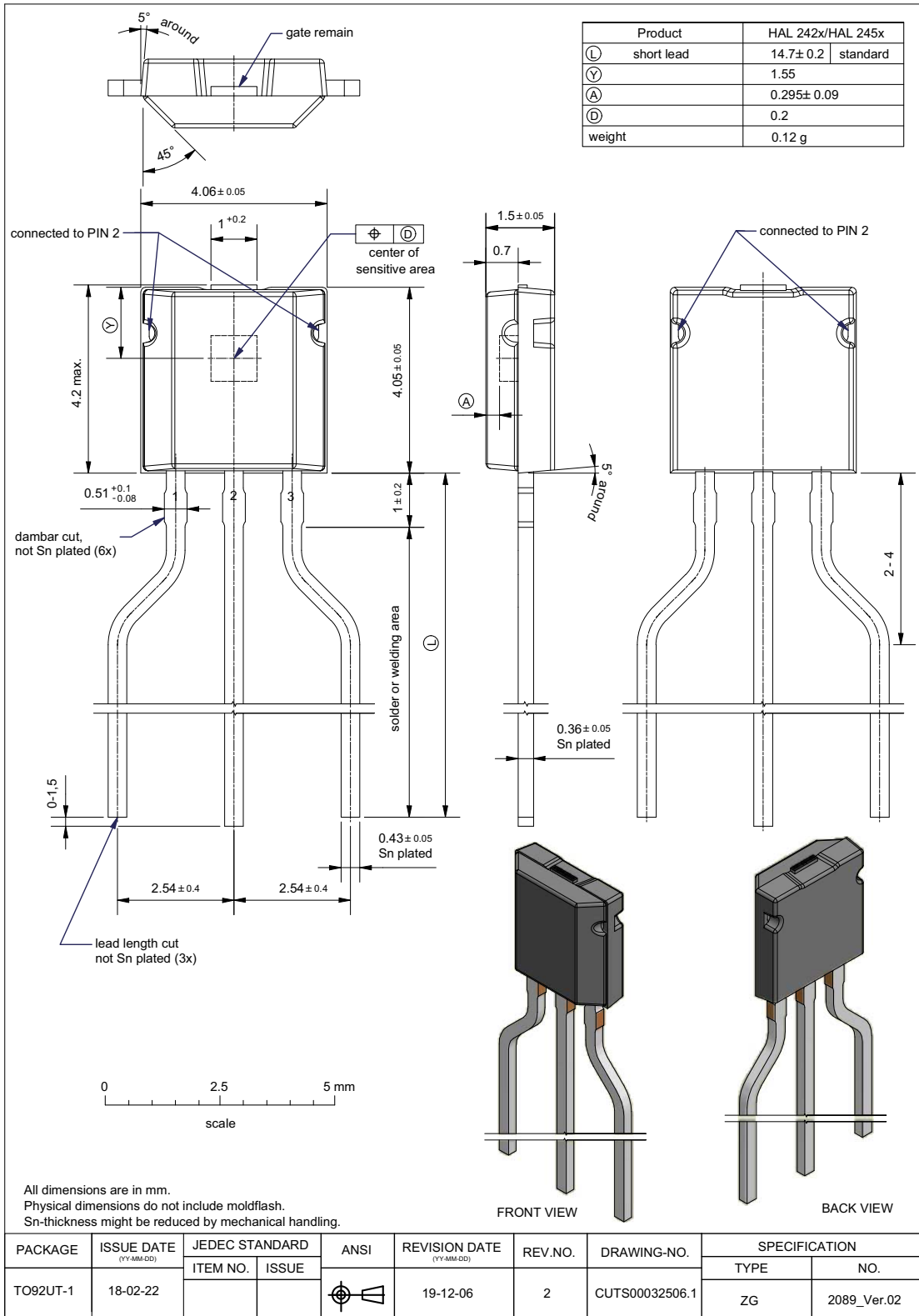

Fig. 4-4:
TO92UT-1 Plastic Transistor Standard UT package, 3 leads, spread

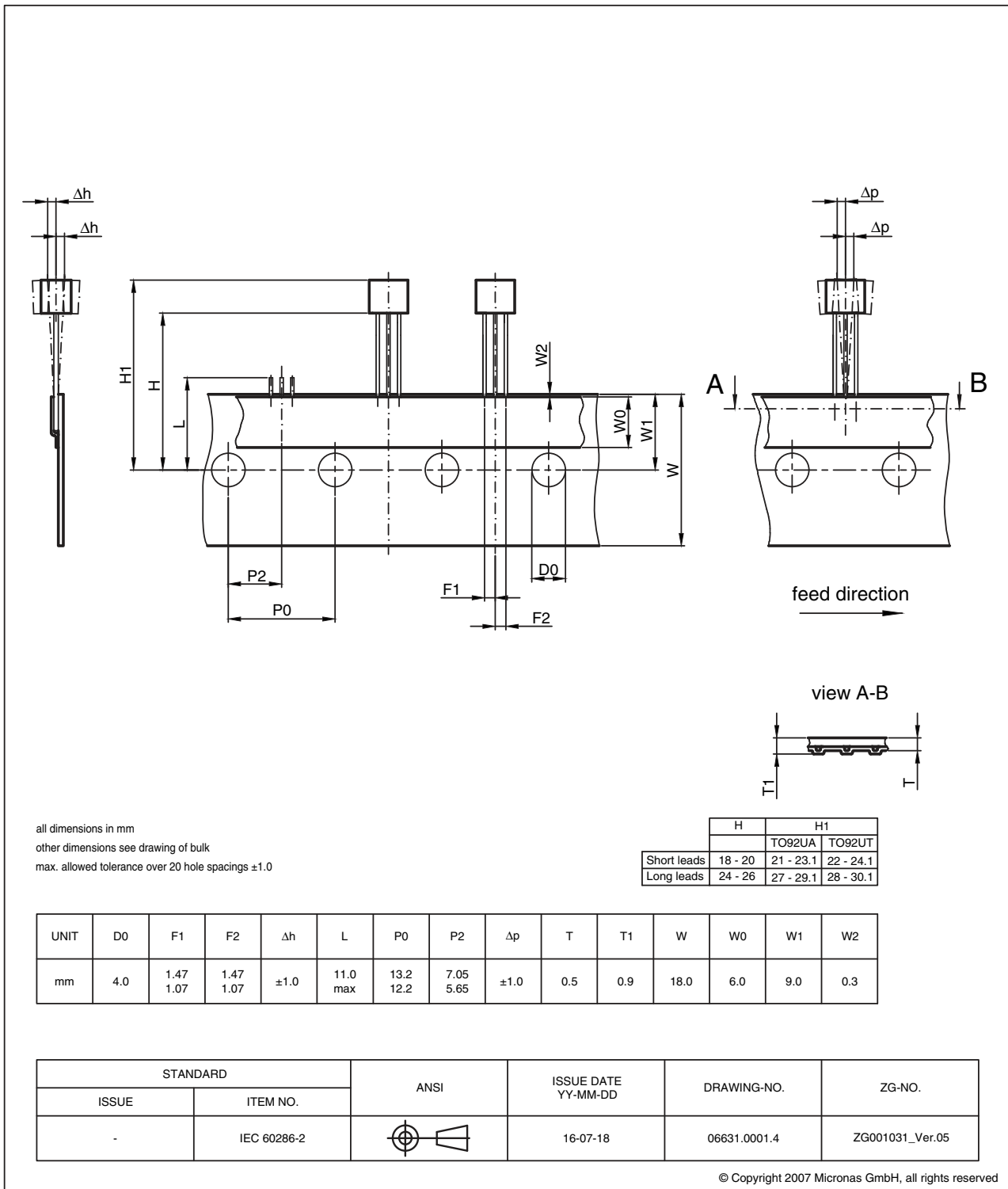

Fig. 4–5:
TO92UA/UT: Dimensions ammpack inline, not spread

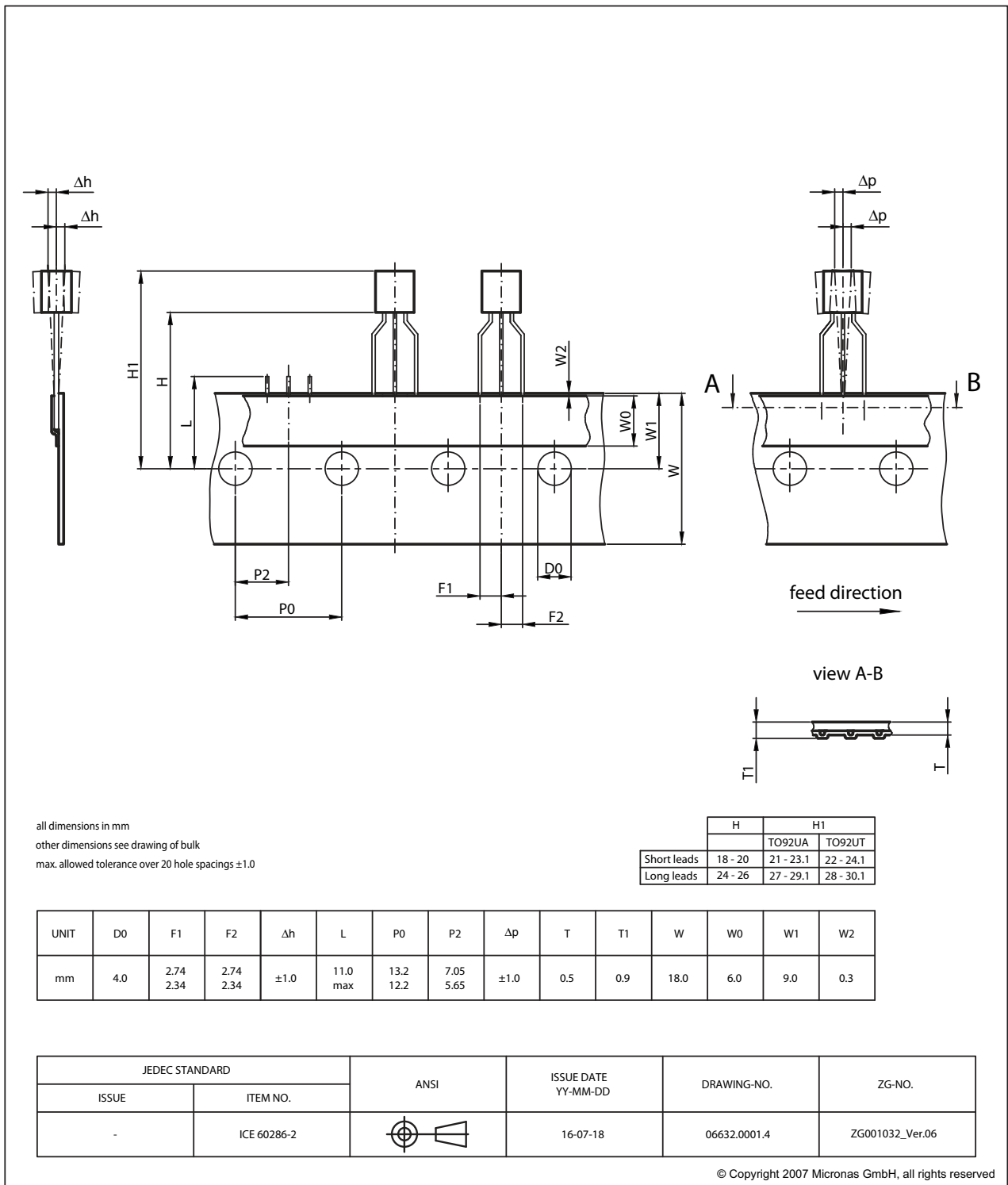

Fig. 4-6:
TO92UA/UT: Dimensions ammpack inline, spread

4.2. Solderability, Welding, Assembly

Information related to solderability, welding, assembly, and second-level packaging is included in the document “Guidelines for the Assembly of Micronas Packages”. It is available on the TDK-Micronas website (<http://www.micronas.com/en/service-center/downloads>) or on the service portal (<http://service.micronas.com>).

4.3. Pin Connections and Short Descriptions

Pin No.	Pin Name	Type	Short Description
SOIC8 Package			
1	VSUP	SUPPLY	Supply Voltage
2	Gnd	GND	Ground
4	OUT	I/O	Output and Programming Pin
All remaining pins (3, 5, 6, 7, 8) must be connected to ground			
Pin No.	Pin Name	Type	Short Description
TO92UT Package			
1	VSUP	SUPPLY	Supply Voltage
2	Gnd	GND	Ground
3	OUT	I/O	Output and Programming Pin

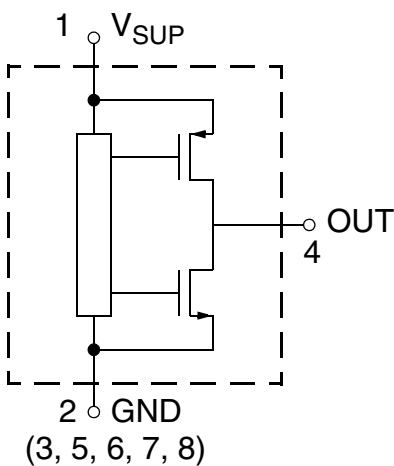

Fig. 4–7: Pin configuration (SOIC8)

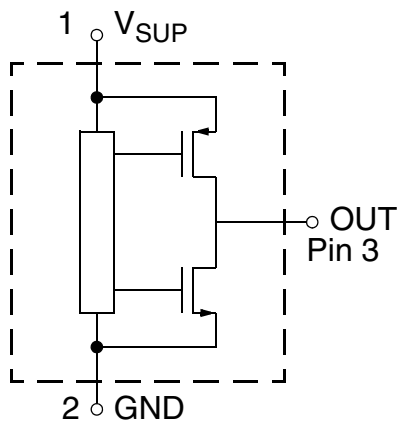

Fig. 4–8: Pin configuration (TO92UT)

4.4. Physical Dimensions

4.4.1. Dimensions of Sensitive Area

250 μm x 250 μm

4.5. Absolute Maximum Ratings

Stresses beyond those listed in the “Absolute Maximum Ratings” may cause permanent damage to the device. This is a stress rating only. Functional operation of the device at these conditions is not implied. Exposure to absolute maximum rating conditions for extended periods will affect device reliability.

This device contains circuitry to protect the inputs and outputs against damage due to high static voltages or electric fields; however, it is advised that normal precautions must be taken to avoid application of any voltage higher than absolute maximum-rated voltages to this circuit.

All voltages listed are referenced to ground (GND).

Symbol	Parameter	Pin	Min.	Max.	Unit	Condition
V _{SUP}	Supply Voltage	VSUP	-8.5	10	V	t < 96 h ⁴⁾
			-18	18	V	t < 1h ⁴⁾
V _{OUT}	Output Voltage	OUT	-6 ¹⁾	18	V	t < 1h ⁴⁾
V _{OUT} - V _{SUP}	Excess of Output Voltage over Supply Voltage	OUT, VSUP	-	2	V	
T _J	Junction Temperature Range		-50	190 ²⁾	°C	t < 96h ⁴⁾
T _{storage}	Transportation/Short-Term Storage Temperature	-	-55	150	°C	Device only without packing material
V _{ESD_SOIC8}	ESD Protection for SOIC8 package ³⁾	All Pins	-2	2	kV	HBM AEC-Q-100-002 (100 pF / 1.5 kΩ)
		VSUP vs. GND	-8	8	kV	
		OUT vs. GND	-8	8	kV	
		VSUP vs. OUT	-8	8	kV	
V _{ESD_TO92}	ESD Protection for TO92UT package ³⁾	All Pins	-8	8	kV	HBM AEC-Q-100-002 (100 pF / 1.5 kΩ)

1) internal protection resistor = 50 Ω

2) for 96 hrs - Please contact TDK-Micronas for other temperature requirements.

3) For system ESD robustness, pins not used have to be connected to GND.

4) No cumulated stress

4.6. Storage and Shelf Life

Information related to storage conditions of Micronas sensors is included in the document “Guidelines for the Assembly of Micronas Packages”. It gives recommendations linked to moisture sensitivity level and long-term storage.

It is available on the TDK-Micronas website (<http://www.micronas.com/en/service-center/downloads>) or on the service portal (<http://service.micronas.com>).

4.7. Recommended Operating Conditions

Functional operation of the device beyond those indicated in the “Recommended Operating Conditions/Characteristics” is not implied and may result in unpredictable behavior, reduce reliability and lifetime of the device.

All voltages listed are referenced to ground (GND).

Symbol	Parameter	Pin	Min.	Typ.	Max.	Unit	Remarks
V _{SUP}	Supply Voltage	VSUP	4.5	5	5.5	V	
I _{OUT}	Continuous Output Current	OUT	-1.2	-	1.2	mA	
R _L	Load Resistor	OUT	5.0	10	-	kΩ	Can be pull-up or pull-down resistor
C _L	Load Capacitance	OUT	0.33	10	600	nF	
N _{PRG}	Number of EEPROM Programming Cycles ¹⁾	-	-	-	100	cycles	0 °C < T _{amb} < 55 °C
N _{PRGNV}	Number of NVRAM Programming Cycles	-	-	-	5	cycles	0 °C < T _{amb} < 55 °C
T _J	Junction Temperature Range ²⁾	-	-40 -40 -40	-	125 150 170	°C	for 8000 h ³⁾ for 2000 h ³⁾ for 1000 h ³⁾
¹⁾ In the EEPROM, it is not allowed to program only one single address within a 'bank' in the memory. In case of programming one single address the complete bank has to be programmed. ²⁾ Depends on the temperature profile of the application. Please contact TDK-Micronas for lifetime calculations. ³⁾ Time values are not cumulative.							

4.8. Characteristics

at $T_J = -40\text{ °C}$ to $+170\text{ °C}$, $V_{SUP} = 4.5\text{ V}$ to 5.5 V , $GND = 0\text{ V}$ after programming and locking, at Recommended Operation Conditions if not otherwise specified in the column "Conditions".

Typical Characteristics for $T_J = 25\text{ °C}$ and $V_{SUP} = 5\text{ V}$.

Symbol	Parameter	Pin	Min.	Typ.	Max.	Unit	Conditions
I_{SUP}	Supply Current over Temperature Range	VSUP	–	7	11	mA	
	Resolution ⁵⁾	OUT	–	12	–	bit	ratiometric to V_{SUP} ¹⁾
DNL	Differential Non-Linearity of D/A Converter ⁴⁾	OUT	–0.9	0	0.9	LSB	Test limit at 25 °C ambient temperature
INL	Non-Linearity of Output Voltage over Temperature ⁶⁾	OUT	–0.3	0	0.3	% V_{SUP}	²⁾ For $V_{out} = 0.35\text{ V} \dots 4.65\text{ V}$; $V_{SUP} = 5\text{ V}$; Linear Setpoint Characteristics
E_R	Ratiometric Error of Output over Temperature (Error in V_{OUT} / V_{SUP})	OUT	–0.25	0	0.25	%	Max of [$V_{OUT5} - V_{OUT4.5}$ and $V_{OUT5.5} - V_{OUT5}$] at $V_{OUT} = 10\%$ and $90\% V_{SUP}$
V_{offset}	Offset Drift over Temperature Range ⁶⁾ $V_{OUT}(B = 0\text{ mT})_{25\text{ °C}} - V_{OUT}(B = 0\text{ mT})_{max}$	OUT	0	0.1	0.2	% V_{SUP}	$V_{SUP} = 5\text{ V}$; BARREL SHIFTER = 3 ($\pm 50\text{ mT}$)
ΔV_{OUTCL}	Accuracy of Output Voltage at Clamping Low Voltage over Temperature Range ⁵⁾	OUT	–11	0	11	mV	$R_L = 5\text{ k}\Omega$, $V_{SUP} = 5\text{ V}$ Spec values are derived from resolution of the registers DAC_CMPHI/LO and V_{offset} .
ΔV_{OUTCH}	Accuracy of Output Voltage at Clamping High Voltage over Temperature Range ⁵⁾	OUT	–11	0	11	mV	
V_{OUTH}	Upper Limit of Signal Band ³⁾	OUT	93	–	–	% V_{SUP}	$V_{SUP} = 5\text{ V}$, $-1\text{ mA} \leq I_{OUT} \leq 1\text{ mA}$
V_{OUTL}	Lower Limit of Signal Band ³⁾	OUT	–	–	7	% V_{SUP}	$V_{SUP} = 5\text{ V}$, $-1\text{ mA} \leq I_{OUT} \leq 1\text{ mA}$
f_{OSC}	Internal Oscillator Frequency over Temperature Range	–	–	4	–	MHz	
$t_{r(O)}$	Step Response Time of Output ⁶⁾	OUT	–	0.4	0.6	ms	$C_L = 10\text{ nF}$, time from 10% to 90% of final output voltage for a step like signal B_{step} from 0 mT to B_{max}
t_{POD}	Power-Up Time (Time to Reach Certain Output Accuracy) ⁶⁾	OUT	–	–	1.7 8.0	ms ms	Additional error of 1% Full-Scale Full accuracy
BW	Small Signal Bandwidth (-3 dB) ⁶⁾	OUT	–	2	–	kHz	
V_{OUTrms}	Output Noise Voltage RMS ⁶⁾	OUT	–	–	1.5	mV	BARREL SHIFTER=3 Overall gain in signal path = 1 External circuitry according to Fig. 5–1 on page 38 with low-noise supply
R_{OUT}	Output Resistance over Recommended Operating Range	OUT	–	1	10	Ω	$V_{OUTLmax} \leq V_{OUT} \leq V_{OUTHmin}$

¹⁾ Output DAC full scale = 5 V ratiometric, Output DAC offset = 0 V, Output DAC LSB = $V_{SUP}/4096$

²⁾ if more than 50% of the selected magnetic-field range is used and the temperature compensation is suitable.

INL = $V_{OUT} - V_{OUTLSF}$ with V_{OUTLSF} = Least Square Fit through measured output voltage

³⁾ Signal Band Area with full accuracy is located between V_{OUTL} and V_{OUTH} . The sensor accuracy is reduced below V_{OUTL} and above V_{OUTH}

⁴⁾ External package stress or overmolding might change this parameter

⁵⁾ Guaranteed by Design

⁶⁾ Characterized on small sample size, not tested

Symbol	Parameter	Pin	Min.	Typ.	Max.	Unit	Conditions
SOIC8 Package							
R _{thja}	Thermal Resistance						
	Junction to Air	–	–	–	142	K/W	Determined with a 1s0p board
R _{thjc}	Junction to Case	–	–	–	88	K/W	Determined with a 1s1p board
		–	–	–	33	K/W	Determined with a 1s0p board
		–	–	–	22	K/W	Determined with a 1s1p board
TO92UT Package							
R _{thja}	Thermal Resistance						
	Junction to Air	–	–	–	232	K/W	Determined with a 1s0p board
R _{thjc}	Junction to Case	–	–	–	136	K/W	Determined with a 2s2p board
		–	–	–	40	K/W	Determined with a 1s0p board
		–	–	–	36	K/W	Determined with a 2s2p board
1) Guaranteed by Design							
2) Characterized on small sample size, not tested.							

4.9. Open-Circuit Detection

at $T_J = -40\text{ °C}$ to $+170\text{ °C}$, Typical Characteristics for $T_J = 25\text{ °C}$

Symbol	Parameter	Pin	Min.	Typ.	Max.	Unit	Comment
V_{OUT}	Output Voltage at Open V_{SUP} Line	OUT	0	0	0.15	V	$V_{SUP} = 5\text{ V}$ $R_L = 10\text{ k}\Omega$ to $200\text{ k}\Omega$
			0	0	0.2	V	$V_{SUP} = 5\text{ V}$ $R_L = 5\text{ k}\Omega$ to $10\text{ k}\Omega$
V_{OUT}	Output Voltage at Open GND Line	OUT	4.85	4.9	5.0	V	$V_{SUP} = 5\text{ V}$ $R_L = 10\text{ k}\Omega$ to $200\text{ k}\Omega$
			4.8	4.9	5.0	V	$V_{SUP} = 5\text{ V}$ $R_L = 5\text{ k}\Omega$ to $10\text{ k}\Omega$

R_L : Can be pull-up or pull-down resistor

4.10. Overvoltage and Undervoltage Detection

at $T_J = -40\text{ °C}$ to $+170\text{ °C}$, Typical Characteristics for $T_J = 25\text{ °C}$, after programming and locking

Symbol	Parameter	Pin	Min.	Typ.	Max.	Unit	Test Conditions
$V_{SUP,UV}$	Undervoltage Detection Level	VSUP	3.3	3.9	4.3	V	
$V_{SUP,UVhyst}$	Undervoltage Detection Level Hysteresis ¹⁾	VSUP	–	200	–	mV	
$V_{SUP,OV}$	Overvoltage Detection Level	VSUP	5.6	6.2	6.9	V	
$V_{SUP,OVhyst}$	Overvoltage Detection Level Hysteresis ¹⁾	VSUP	–	225	–	mV	

¹⁾Characterized on small sample size, not tested

4.11. Magnetic Characteristics

at $T_J = -40\text{ °C}$ to $+170\text{ °C}$, $V_{SUP} = 4.5\text{ V}$ to 5.5 V , $GND = 0\text{ V}$ after programming and locking, at Recommended Operation Conditions if not otherwise specified in the column "Conditions".

Typical Characteristics for $T_J = 25\text{ °C}$ and $V_{SUP} = 5\text{ V}$.

Symbol	Parameter	Pin	Min.	Typ.	Max.	Unit	Test Conditions
SENS	Magnetic Sensitivity	$\Delta V_{OUT}/(2 \times RANGE_{ABS})$				mV/mT	Example: For Barrel_shifter=5 and $\Delta V_{OUT} = 4\text{ V}$ $RANGE_{ABS} = 12\text{ mT}$ Sensitivity=4 V/ (2x12mT= 166 mV/mT typ.
$RANGE_{ABS}$	Absolute Range of CFX Register (Magnetic Range) ¹⁾	–	6	–	200	mT	Programmable: See Table 3–2 for relation between barrel shifter and Magnetic Range.
B_{Offset}	Magnetic Offset ¹⁾	OUT	–0.4	0	0.4	mT	$B = 0\text{ mT}$, $I_{OUT} = 0\text{ mA}$, $T_J = 25\text{ °C}$, unadjusted sensor
$\Delta B_{Offset}/\Delta T$	Magnetic Offset Change due to T_J ¹⁾	–	–5	0	5	$\mu\text{T/K}$	$B = 0\text{ mT}$, $I_{OUT} = 0\text{ mA}$ BARREL SHIFTER = 3 ($\pm 50\text{ mT}$)
ES	Error in Magnetic Sensitivity ¹⁾ SOIC8 TO92UT	OUT	–1.5 –1	0 0	1.5 1	%	$V_{SUP} = 5\text{ V}$ BARREL SHIFTER = 3 ($\pm 50\text{ mT}$)
¹⁾ Characterized on small sample size, not tested							

4.11.1. Definition of Sensitivity Error ES

ES is the maximum of the absolute value of the quotient of the normalized measured value¹ over the normalized ideal linear² value minus 1:

$$ES = \max\left(\text{abs}\left(\frac{\text{meas}}{\text{ideal}} - 1\right)\right) \Big|_{[T_{\min}, T_{\max}]}$$

In the example below, the maximum error occurs at -10 °C:

$$ES = \frac{1.001}{0.993} - 1 = 0.8\%$$

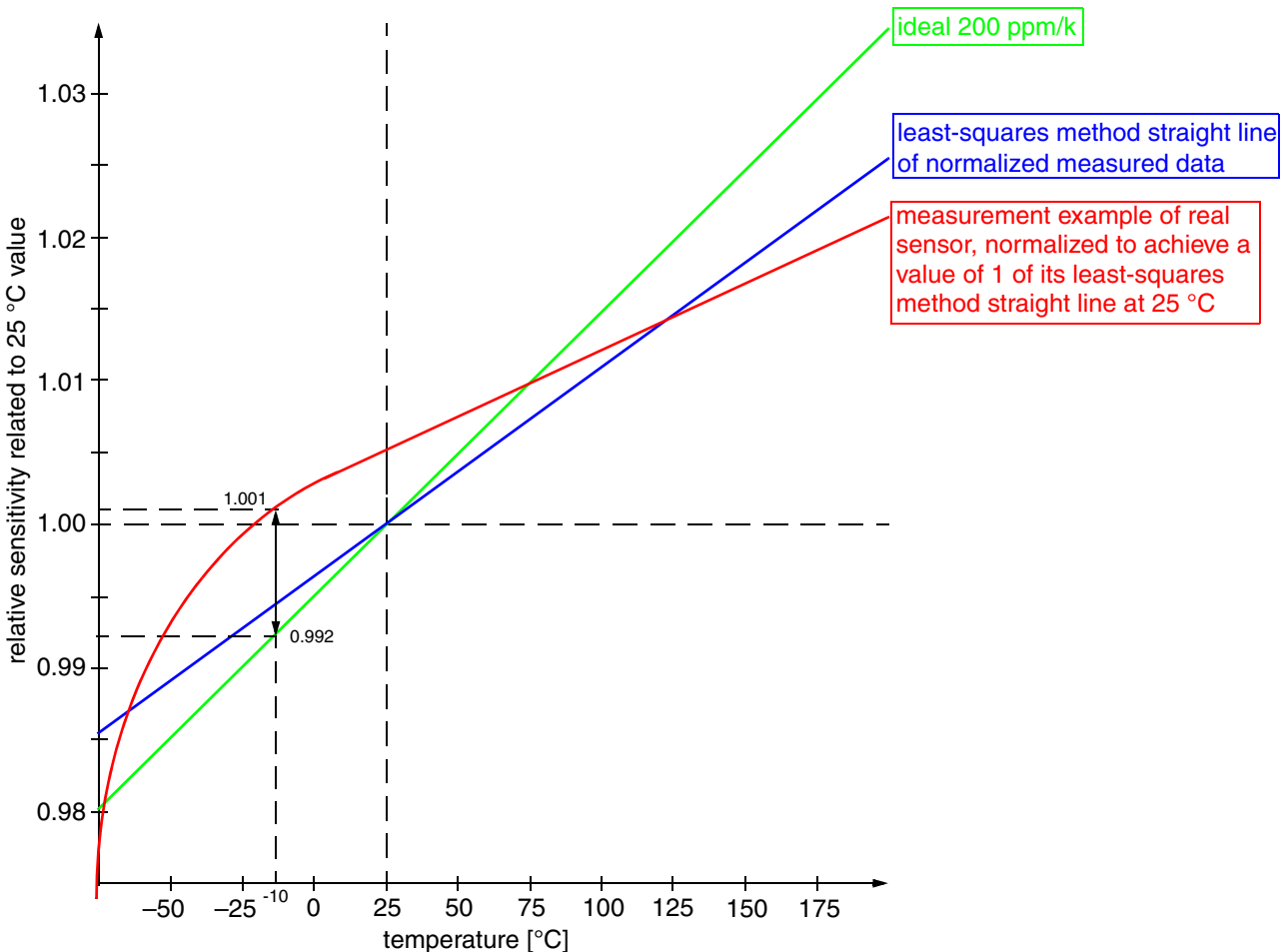

Fig. 4–9: ES definition example

1. normalized to achieve a least-squares method straight line that has a value of 1 at 25 °C
2. normalized to achieve a value of 1 at 25 °C

5. Application Notes

5.1. Application Circuit

For EMC protection, it is recommended to connect one ceramic 47 nF capacitor each between ground and the supply voltage, respectively the output voltage pin.

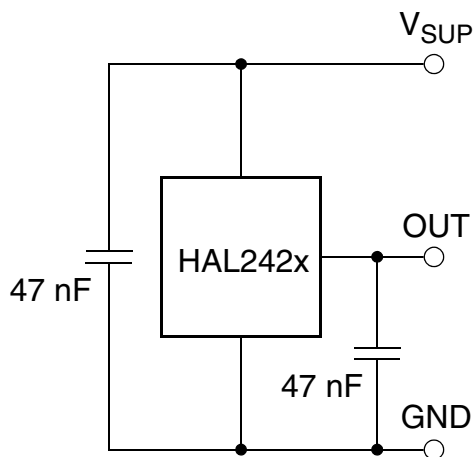

Fig. 5–1: Recommended application circuit

5.2. Use of two HAL 242x in Parallel

Two different HAL 242x sensors which are operated in parallel to the same supply and ground line can be programmed individually as the communication with the sensors is done via their output pins.

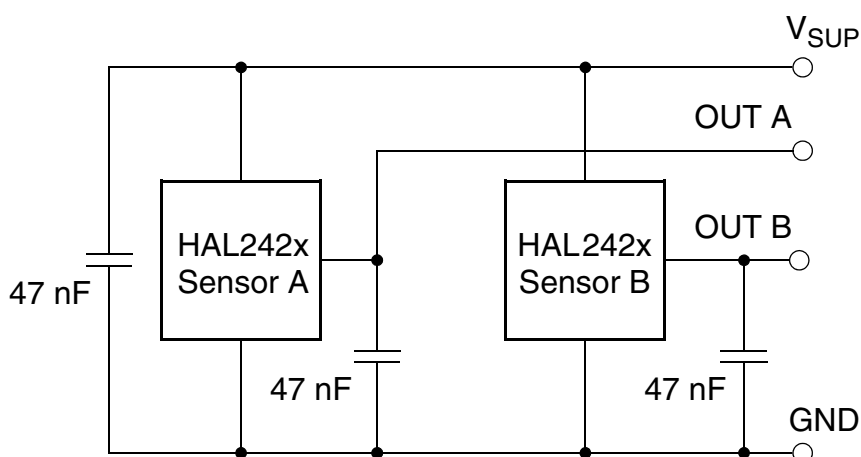

Fig. 5–2: Parallel operation of two HAL 242x

5.3. Ambient Temperature

Due to the internal power dissipation, the temperature on the silicon chip (junction temperature T_J) is higher than the temperature outside the package (ambient temperature T_A).

$$T_J = T_A + \Delta T$$

At static conditions and continuous operation, the following equation applies:

$$\Delta T = I_{SUP} \times V_{SUP} \times R_{thjx}$$

For typical values, use the typical parameters. For worst case calculation, use the max. parameters for I_{SUP} and R_{thjx} (x is representing the different R_{th} value, like junction to ambient R_{thja}), and the max. value for V_{SUP} from the application.

For $V_{SUP} = 5.5 \text{ V}$, $R_{th} = 235 \text{ K/W}$, and $I_{SUP} = 10 \text{ mA}$, the temperature difference $\Delta T = 12.93 \text{ K}$.

For all sensors, the junction temperature T_J is specified. The maximum ambient temperature T_{Amax} can be calculated as:

$$T_{Amax} = T_{Jmax} - \Delta T$$

6. Programming of the Sensor

HAL 242x features two different customer modes. In **Application Mode** the sensor provides a ratiometric analog output voltage. In **Programming Mode** it is possible to change the register settings of the sensor.

After power-up the sensor is always operating in the **Application Mode**. It is switched to the **Programming Mode** by a pulse on the sensor output pin.

6.1. Programming Interface

In Programming Mode the sensor is addressed by modulating a serial telegram on the sensors output pin. The sensor answers with a modulation of the output voltage.

A logical “0” is coded as no level change within the bit time. A logical “1” is coded as a level change of typically 50% of the bit time. After each bit, a level change occurs (see Fig. 6–1).

The serial telegram is used to transmit the EEPROM content, error codes and digital values of the angle information from and to the sensor.

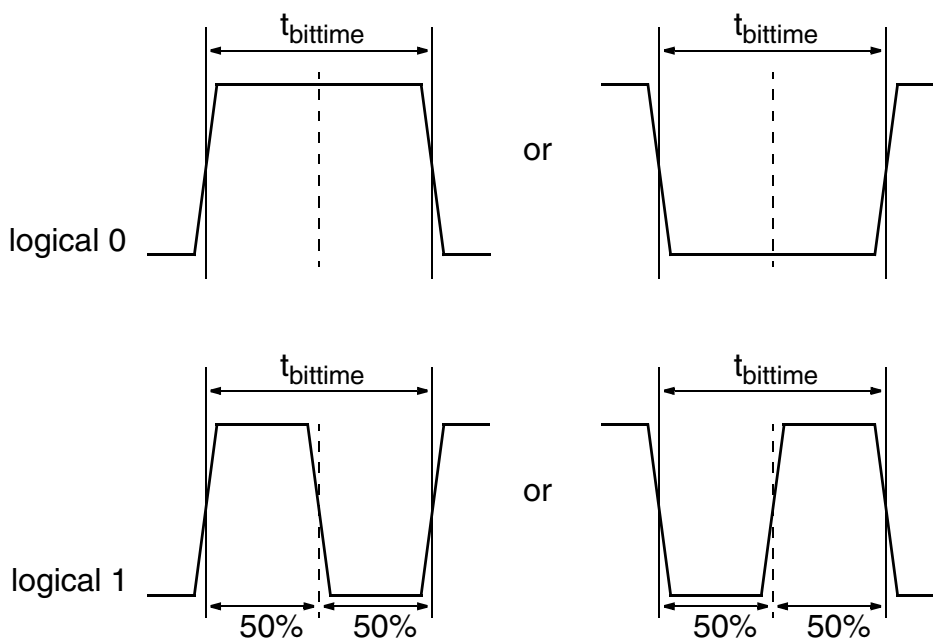

Fig. 6–1: Definition of logical 0 and 1 bit

A description of the communication protocol and the programming of the sensor is available in a separate document (Application Note Programming HAL 242x).

Table 6–1: Telegram parameters (All voltages are referenced to GND.)

Symbol	Parameter	Pin	Limit Values			Unit	Test Conditions
			Min.	Typ.	Max.		
V _{OUTL}	Voltage for Output Low Level during Programming through Sensor Output Pin	OUT	0	–	0.2*V _{SUP}	V	
			0	–	1.0	V	for V _{SUP} = 5 V
V _{OUTH}	Voltage for Output High Level during Programming through Sensor Output Pin	OUT	0.8*V _{SUP}	–	V _{SUP}	V	
			4.0	–	5.0	V	for V _{SUP} = 5 V
V _{SUP-Program}	V _{SUP} Voltage for EEPROM Programming (after PROG and ERASE)	VSUP	5.7	6.0	6.5	V	Supply voltage for bidirectional communication via output pin.
t _{bittime}	Biphase Bit Time	OUT	900	1000	1100	μs	
	Slew rate	OUT	–	2.0	–	V/μs	

6.2. Programming Environment and Tools

For the programming of HAL 242x during product development a programming tool including hardware and software is available on request. It is recommended to use the Micronas tool kit (TDK-MSP V1.x & LabView™ Programming Environment) in order to ease the product development. The details of programming sequences are also available at service.micronas.com.

6.3. Programming Information

For reliability in service, it is mandatory to set the LOCK bit to one and the POUT bit to zero after final adjustment and programming of HAL 242x.

The success of the LOCK process must be checked by reading the status of the LOCK bit after locking and by a negative communication test after a power on reset.

It is also mandatory to check the acknowledge (first and second) of the sensor or to read/check the status of the PROG_DIAGNOSIS register after each write and store sequence to verify if the programming of the sensor was successful. Please check HAL 242x Programming Guide for further details.

Electrostatic Discharges (ESD) may disturb the programming pulses. Please take precautions against ESD.

7. Document History

1. Preliminary Data Sheet: "HAL 242x High-Precision Programmable Linear Hall-Effect Sensor", May 3, 2013, PD000211_001EN. First release of the preliminary data sheet.
2. Preliminary Data Sheet: "HAL 242x High-Precision Programmable Linear Hall-Effect Sensor with Arbitrary Output Characteristics", July 4 2014, PD000211_002EN. Second release of the preliminary data sheet.
Major Change: SOIC8 package added
3. Preliminary Data Sheet: "HAL 242x High-Precision Programmable Linear Hall-Effect Sensor with Arbitrary Output Characteristics", Sept. 19, 2014 PD000211_003EN. Third release of the preliminary data sheet.
Major Changes:
 - SOIC8 package drawing updated
 - Absolute Maximum Ratings – Specification of ESD Protection for SOIC8 package
4. Preliminary Data Sheet: "HAL 242x High-Precision Programmable Linear Hall-Effect Sensor with Arbitrary Output Characteristics", Nov. 26, 2014, PD000211_004EN. Fourth release of the preliminary data sheet.
Major Changes:
 - SOIC8 package drawing updated
 - Position of Sensitive Areas: A4 value changed to 0.48 mm
5. Data Sheet: "HAL 242x High-Precision Programmable Linear Hall-Effect Sensor with Arbitrary Output Characteristics", April 15, 2016, DSH000174_001EN. First release of the data sheet.
Major Changes:
 - TO92UT package drawings updated
 - Ammopack drawings updated
 - Assembly and storage information changed
6. Data Sheet: "HAL 2420, HAL 2425 High-Precision Programmable Linear Hall-Effect Sensors with Arbitrary Output Characteristics", May. 4, 2020, DSH000174_002EN. Second release of the data sheet.
Major Changes:
 - SOIC package drawing updated
 - TO92UT package and tape drawings updated
 - Maximum Ratings: T_{storage} added
 - Characteristics: new value for parameter $V_{\text{OUT,rms}}$
 - Magnetic Characteristics: new values for parameters SENS and $\text{RANGE}_{\text{ABS}}$
7. Data Sheet: "HAL 2420, HAL 2425 High-Precision Programmable Linear Hall-Effect Sensors with Arbitrary Output Characteristics", Nov. 3, 2020, DSH000174_003EN. Third release of the data sheet.
Major Changes:
 - SOIC8 package drawing updated
 - Thermal resistance values for TO92UT package updated