

MVA.L Vertical toggle clamps, long life series

with folded base, steel

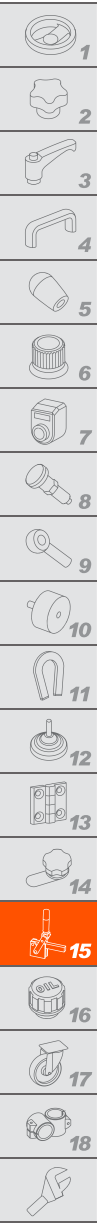

MATERIAL

Black-oxide steel.

ROTATING PINS

Hardened, black-oxide and ground steel.

SUPPORT BUSHING

Hardened, black-oxide and ground steel.

ADJUSTING SCREW AND NUT

Zinc-plated steel.

HANDLE

Polyurethane, red colour.

STANDARD EXECUTIONS

- **MVA.LLA**: with open clamping lever and two folded washers.
- **MVA.LLE**: with solid clamping lever.

CLAMPING BOLTS

To be ordered separately.

FEATURES AND APPLICATIONS

All articulated joints are lubricated with special grease.
 During clamping, the lever is controlled to prevent impact on functioning due to side thrust.
 High-quality materials make Long Life series toggle clamps suitable for medium to heavy loads on welding jigs, carpentry works, moulds and in general whenever high clamping torque and repetitive movements are required.
 Certified for 1.000.000 cycles.

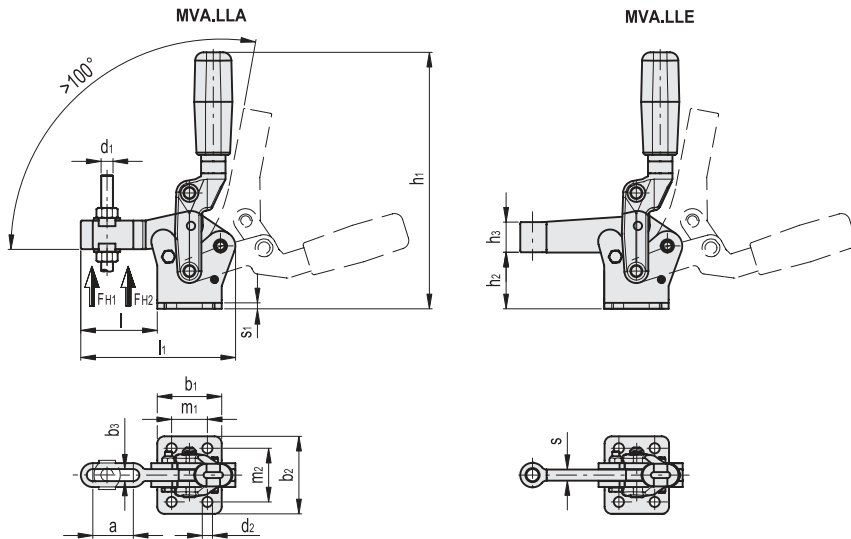
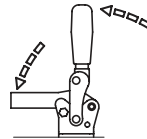

MVA.LLA

METRIC

Code	Description	a	b1	b2	b3	d1	d2	h1	h2	h3	l	l1	l2	m1	m2	s1	FH1 [N]*	FH2 [N]*	△
GG.AA600	MVA.LLA01	32	36	48	6	M6	6.5	136.5	30	16	49	91	51	20	32	3.5	2200	2800	330
GG.AA630	MVA.LLA02	34	54	65	10	M10	8.5	215	50	24	64	129.5	66	30	45	5	4400	8200	1200

MVA.LLE

METRIC

Code	Description	b1	b2	d1	d2	h1	h2	h3	l	l1	m1	m2	s	s1	FH1 [N]*	FH2 [N]*	△
GG.AA610	MVA.LLE01	36	48	M6	6.5	136.5	30	16	44	86	20	32	6	3.5	2200	2800	325
GG.AA640	MVA.LLE02	54	65	M10	8.5	215	50	24	64	129.5	30	45	10	5	4400	8200	1200
GG.AA660	MVA.LLE03	75	75	M12	10.5	280	67	30	74	161	55	55	12	6	8500	-	2200
GG.AA680	MVA.LLE04	90	100	M16	12.5	330	76.5	35	96	203	65	65	16	-	15400	-	4470

Toggle clamps

* Holding force.