

REVISIONS					
P	LTN	DESCRIPTION	DATE	DWN	APVD
A		RELEASED PER ECO-21-003568	16MAR2021	KM	CG

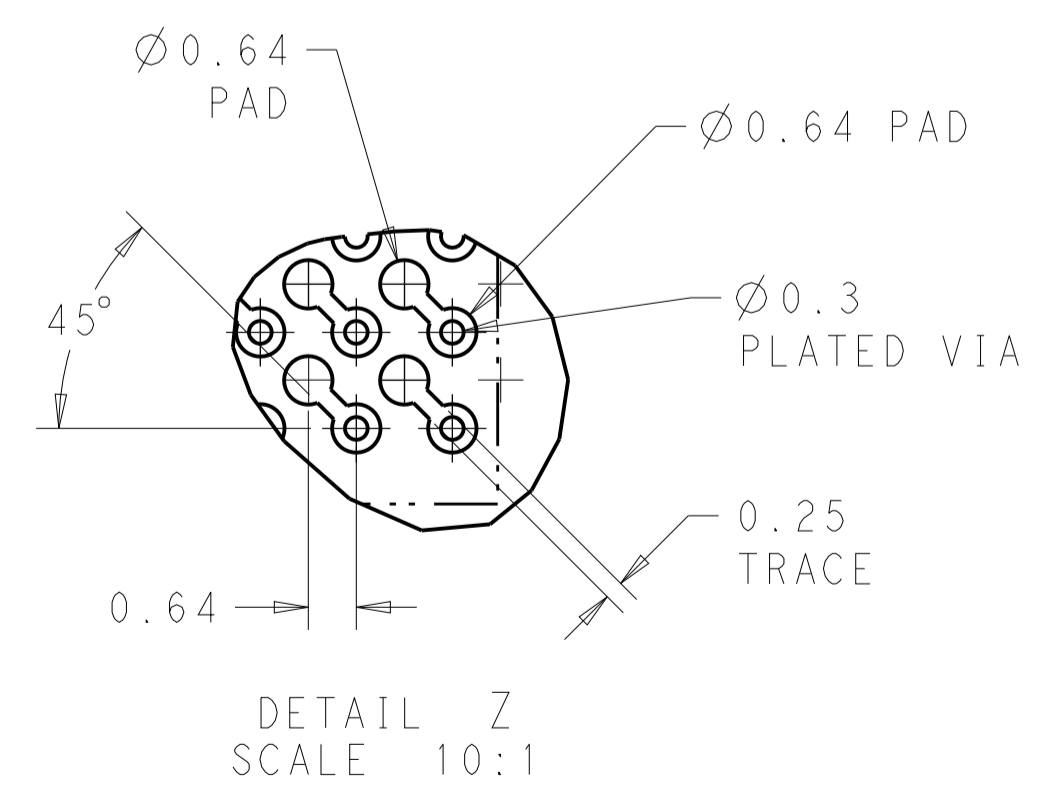
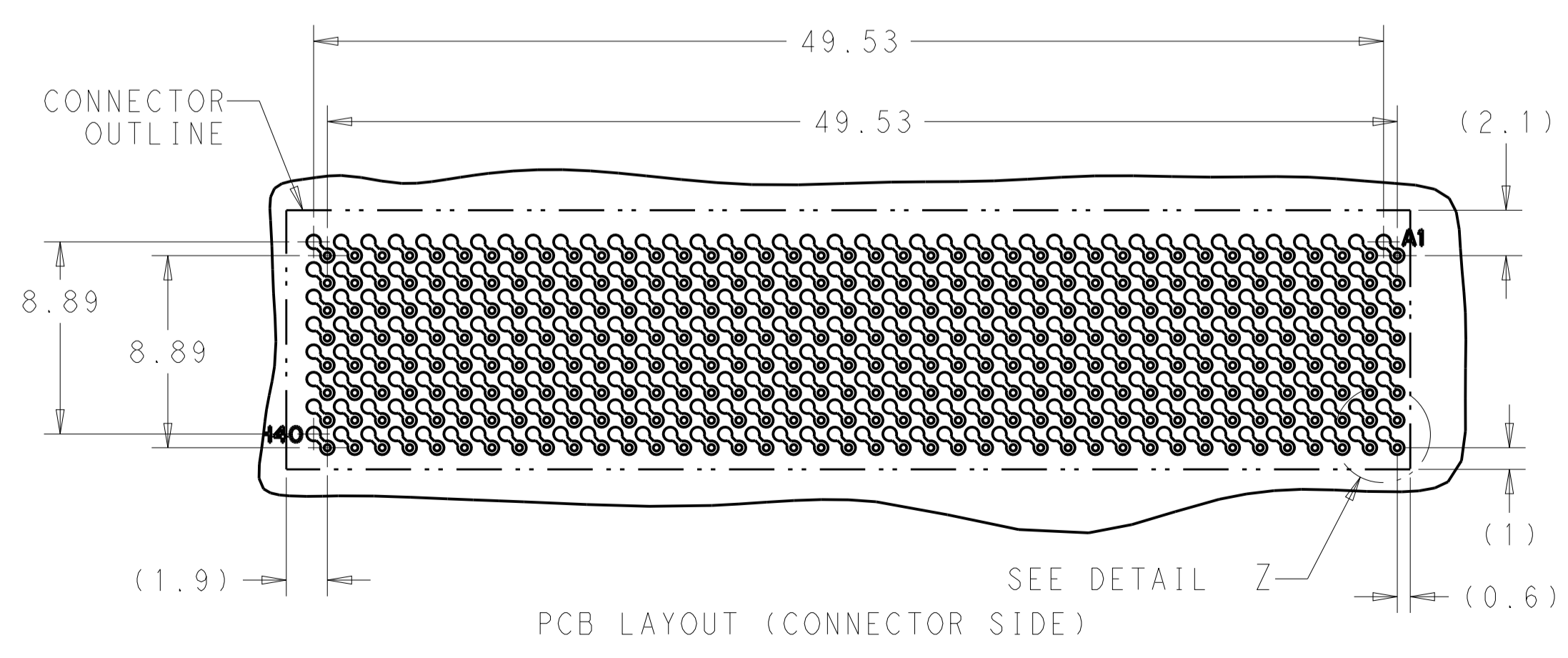
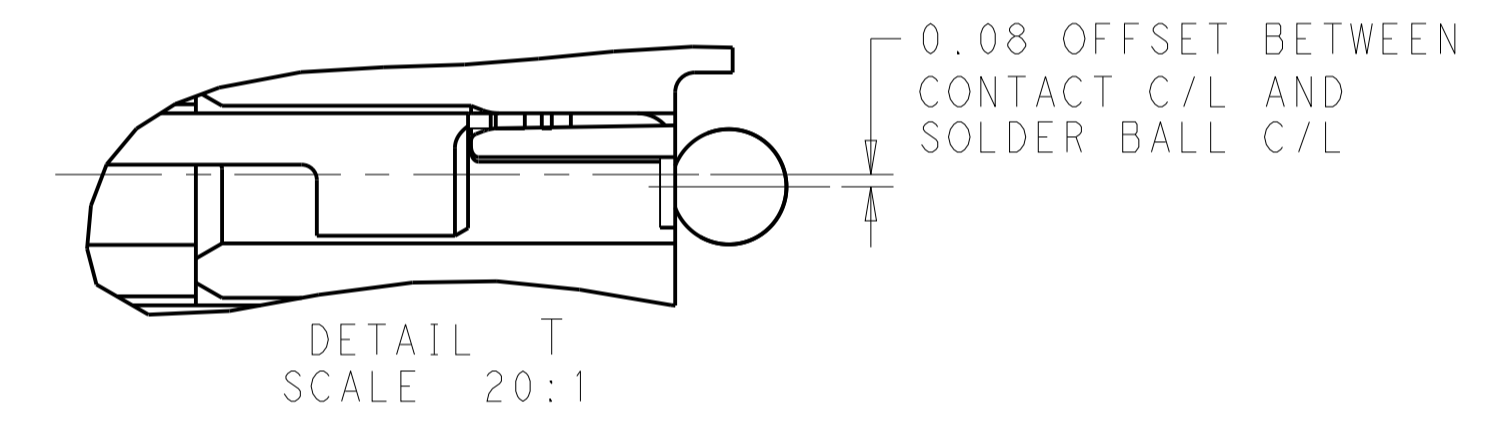
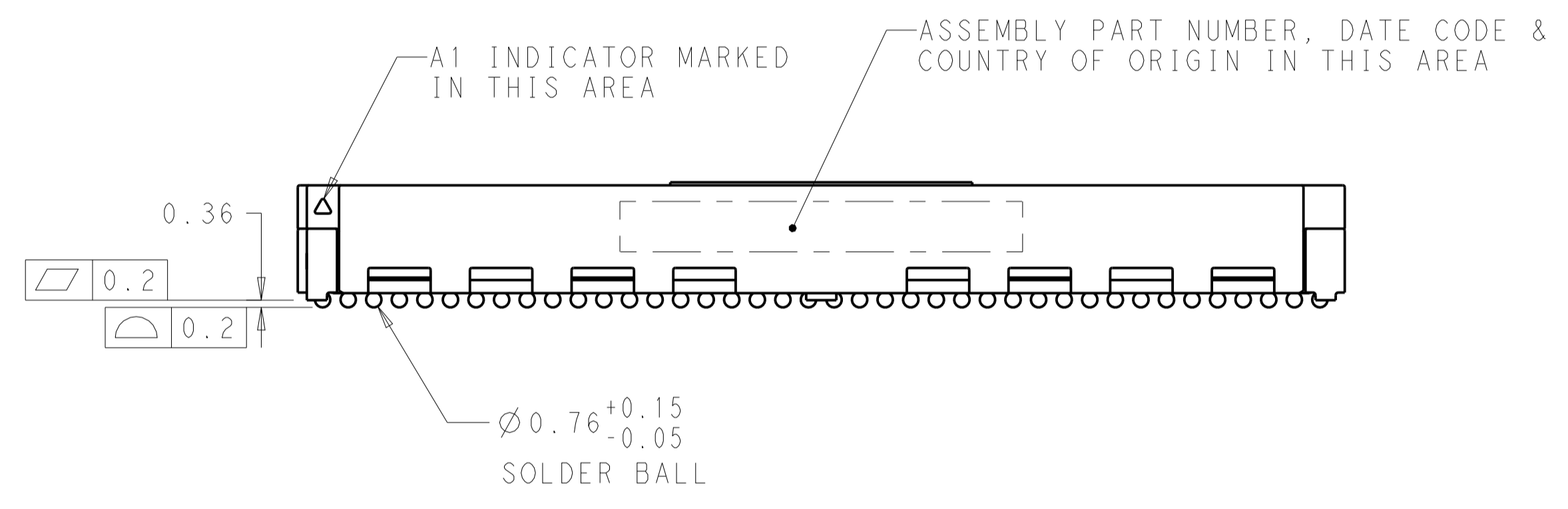
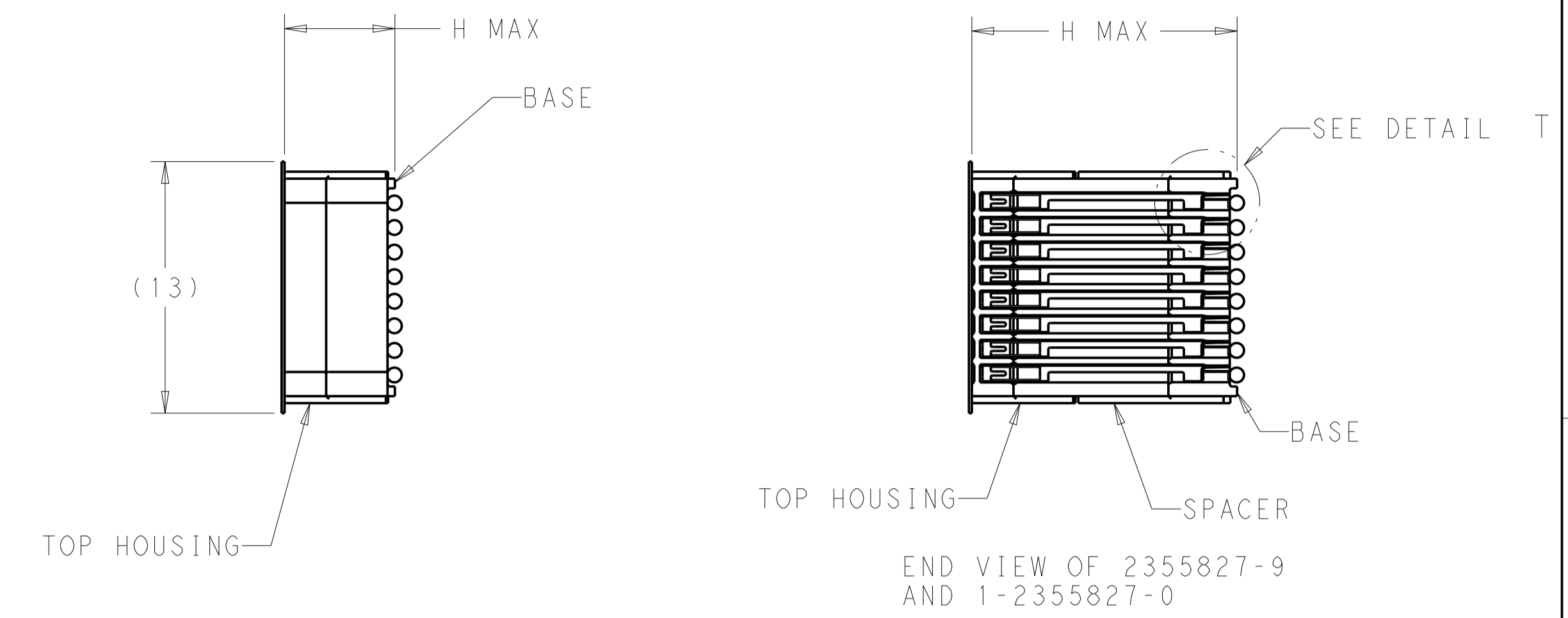
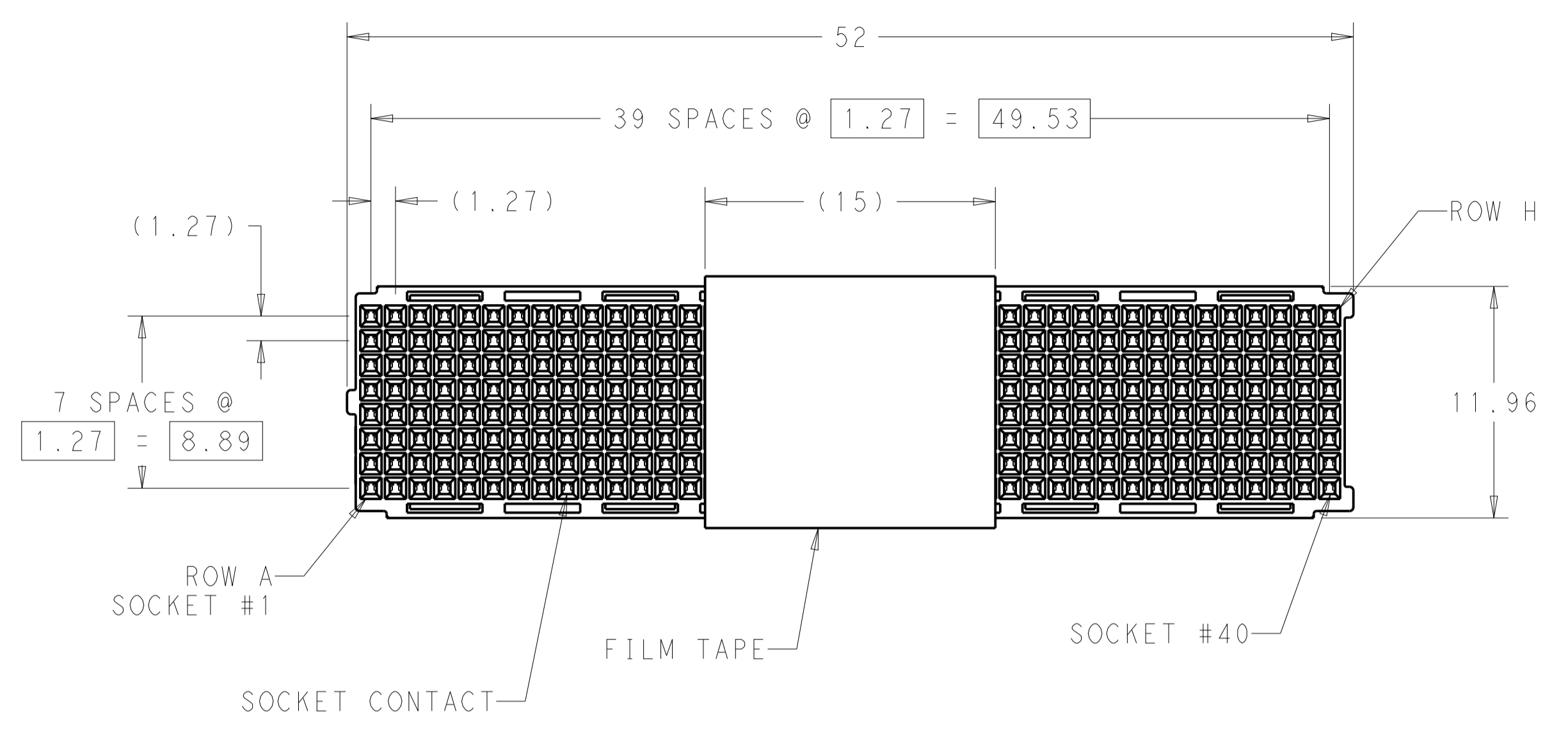

- △ MATERIAL: LCP, COLOR: NATURAL
 CONTACT: BERYLLIUM COPPER
 SOLDER BALL: SEE TABLE
 FILM TAPE: KAPTON WITH SILICONE ADHESIVE
- △ FINISH: CONTACT: GOLD (SEE TABLE) ON MATING AREA OVER NICKEL ON ENTIRE CONTACT.
- 3. PRODUCT IS PACKAGE ON TAPE AND REEL.
- △ DIAGRAM REPRESENTS THE DE-REELING DIRECTION OF THE PACKAGED CONNECTORS.

2102429-2	28	18	1.27µm	14	LEAD FREE	1-2355827-0
2102429-1	28	18	1.27µm	14	TIN LEAD	2355827-9
2102429-2	20	10	1.27µm	6	LEAD FREE	2355827-2
2102429-1	20	10	1.27µm	6	TIN LEAD	2355827-1
MATING PART NUMBER	T	STACK HEIGHT (mm)	GOLD PLATING THICKNESS	H MAX REF	SOLDER BALL MATERIAL	PART NUMBER

THIS DRAWING IS A CONTROLLED DOCUMENT.

DIMENSIONS: mm

TOLERANCES UNLESS OTHERWISE SPECIFIED:

0 PLC	±
1 PLC	±0.5
2 PLC	±0.13
3 PLC	±0.013
4 PLC	±0.001
ANGLES	±1°

MATERIAL: △ FINISH: △

OWN: H. MILLER 06FEB2020
 CHK: C. GINGRICH 07FEB2020
 APVD: K. THACKSTON 16MAR2021

PRODUCT SPEC: 108-160206
 APPLICATION SPEC: 114-13279

WEIGHT: -
 CUSTOMER DRAWING

NAME: ASSEMBLY, SOCKET, 320 POSITION, MINI BOX STACKING CONNECTOR, LOW FORCE

SIZE: A1
 CAGE CODE: 100779
 DRAWING NO: 2355827

RESTRICTED TO: -

SCALE: 4:1 SHEET 1 OF 2 REV A

REVISIONS				
P.	LTN	DESCRIPTION	DATE	APVD
-	-	SEE SHEET 1	-	-

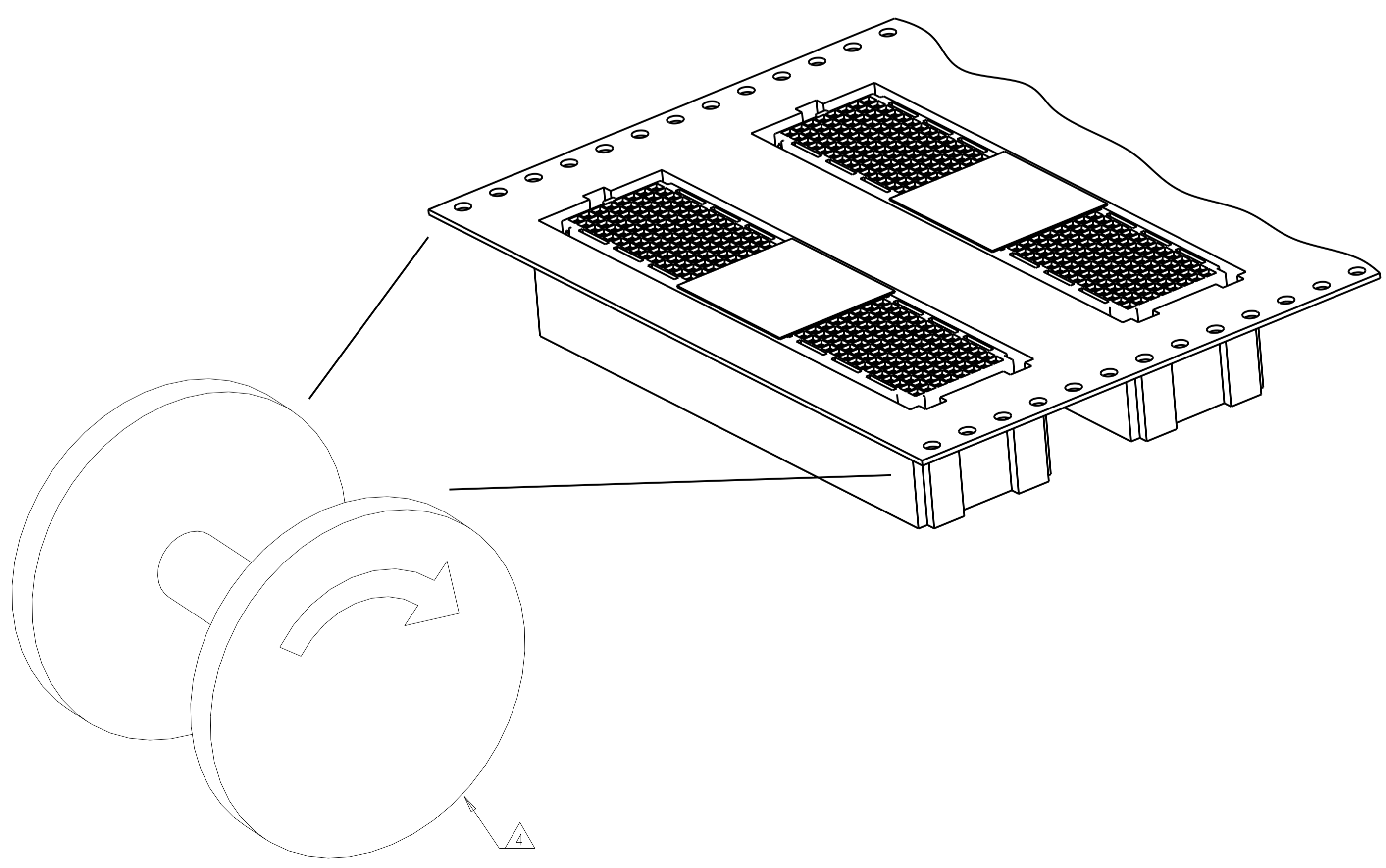
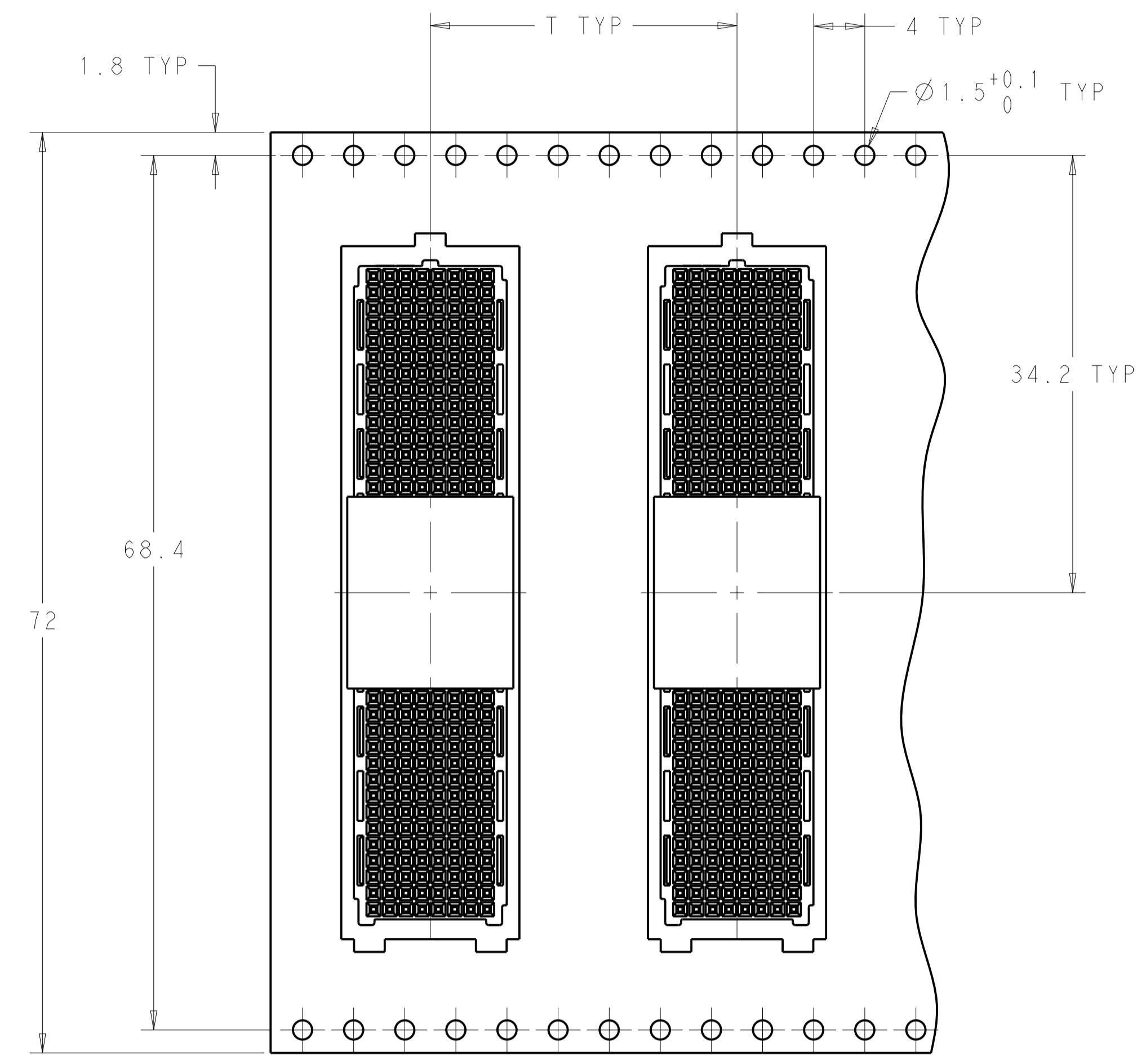

THIS DRAWING IS A CONTROLLED DOCUMENT.		DWN K. MILLER 06FEB2020	
DIMENSIONS: mm		CHK C. GINGRICH 07FEB2020	
TOLERANCES UNLESS OTHERWISE SPECIFIED:		APVD K. THACKSTON 16MAR2021	NAME ASSEMBLY, SOCKET, 320 POSITION, MINI BOX STACKING CONNECTOR LOW FORCE
0 PLC ± 1 PLC ±0.5 2 PLC ±0.13 3 PLC ±0.013 4 PLC ±0.0001 ANGLES ±1°		PRODUCT SPEC 108-160206	SIZE A1
MATERIAL		APPLICATION SPEC 114-13279	CAGE CODE 00779
FINISH		WEIGHT	DRAWING NO C=2355827
CUSTOMER DRAWING		SCALE 4:1	SHEET 2 OF 2
		REV A	