

THIS DRAWING IS UNPUBLISHED. RELEASED FOR PUBLICATION  
 © COPYRIGHT - By - ALL RIGHTS RESERVED.

REVISIONS				
P	LTR	DESCRIPTION	DATE	APVD
E1		REVISED PER ECR-20-100585	20OCT2020	S.K D.Z

- MATERIAL :  
HOUSING : NYLON, UL94-V0  
PIN : BRASS.
- FINISH:  
PIN : 80u" MIN. TIN PLATED ON CONTACT AREA.
- COMPLY WITH GLOW WIRE REQUIREMENTS FOR PARTS OF NON-METALLIC MATERIAL SUPPORTING A CURRENT-CARRYING CONNECTION DETAILED IN IEC 60335-1, SECTION 30(GWT)

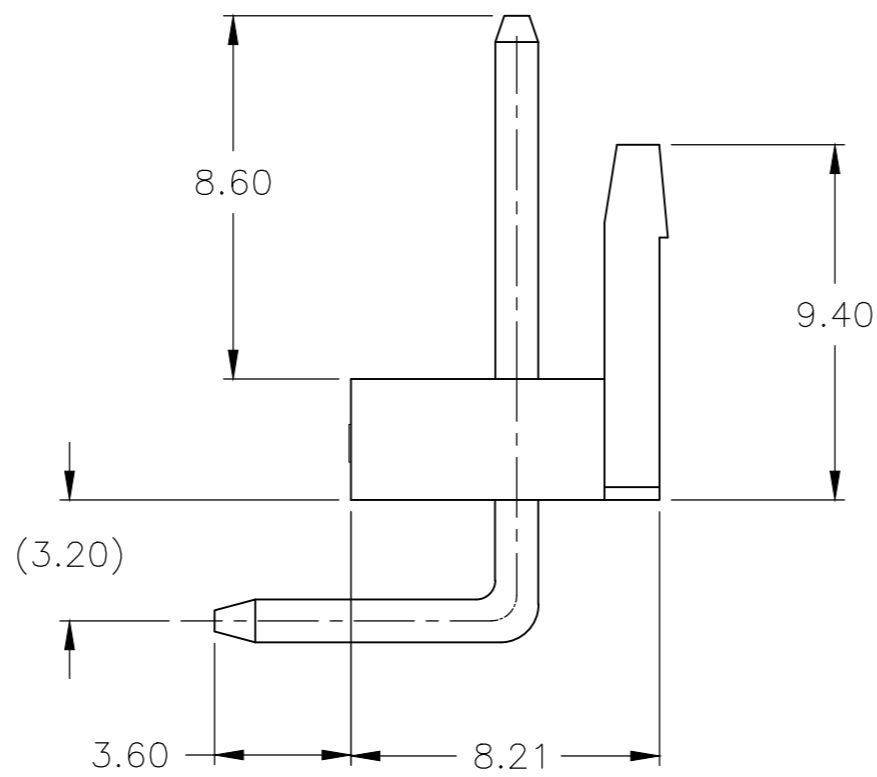
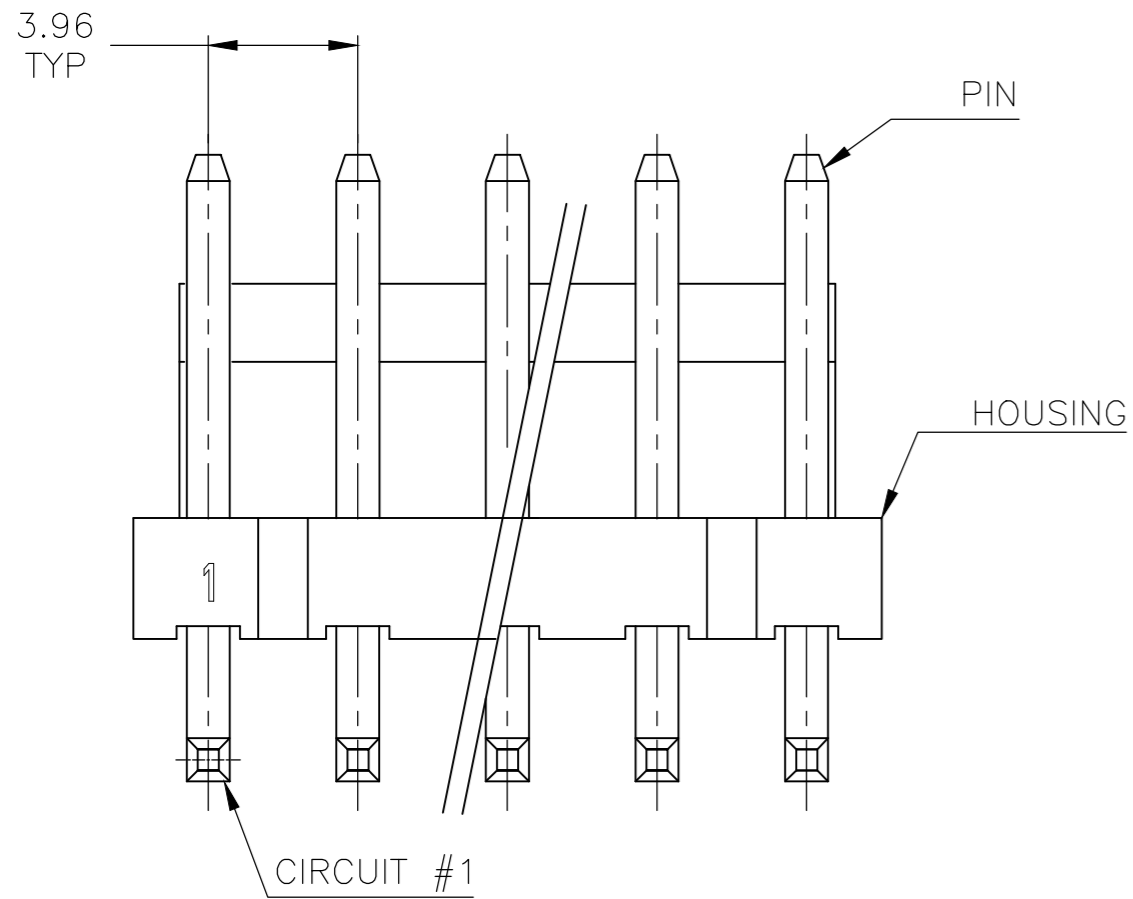
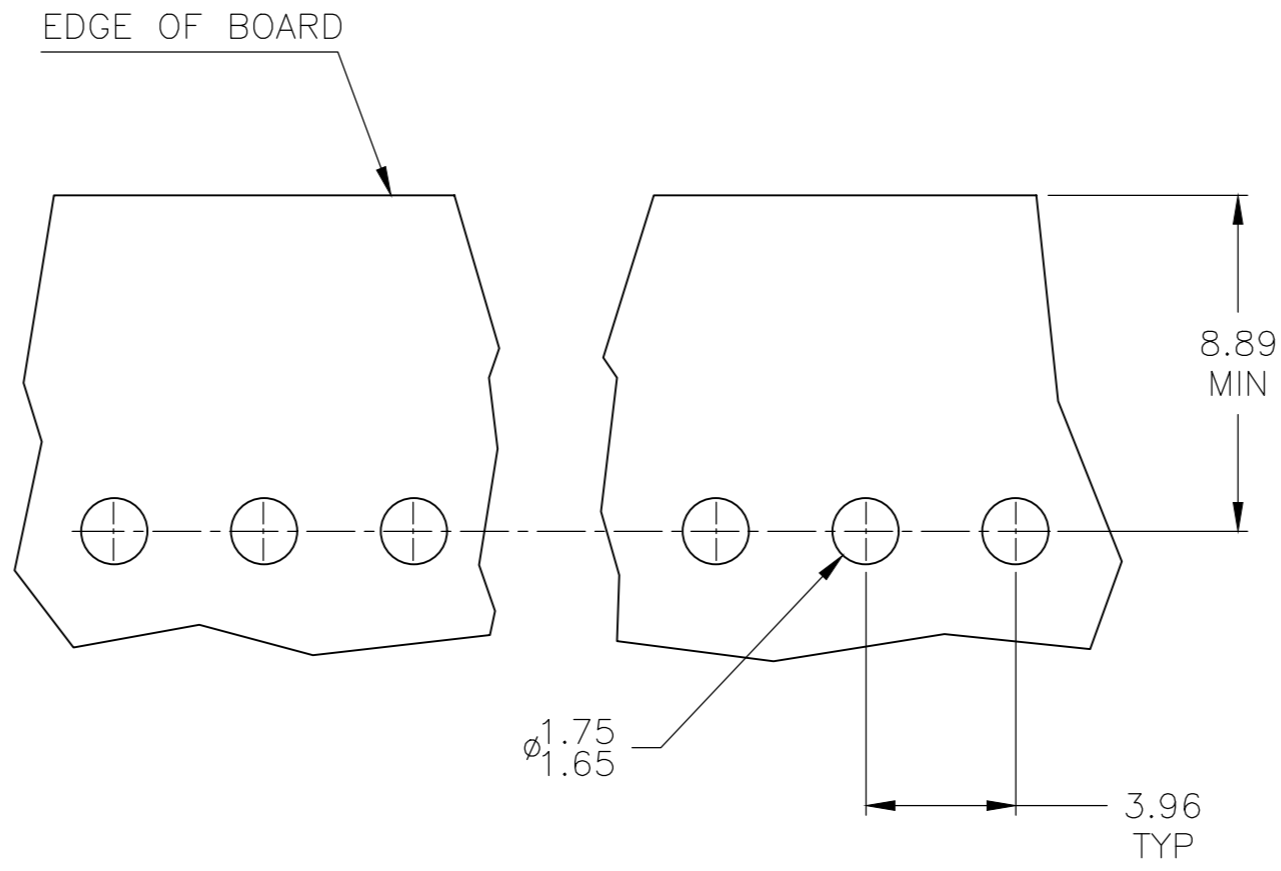
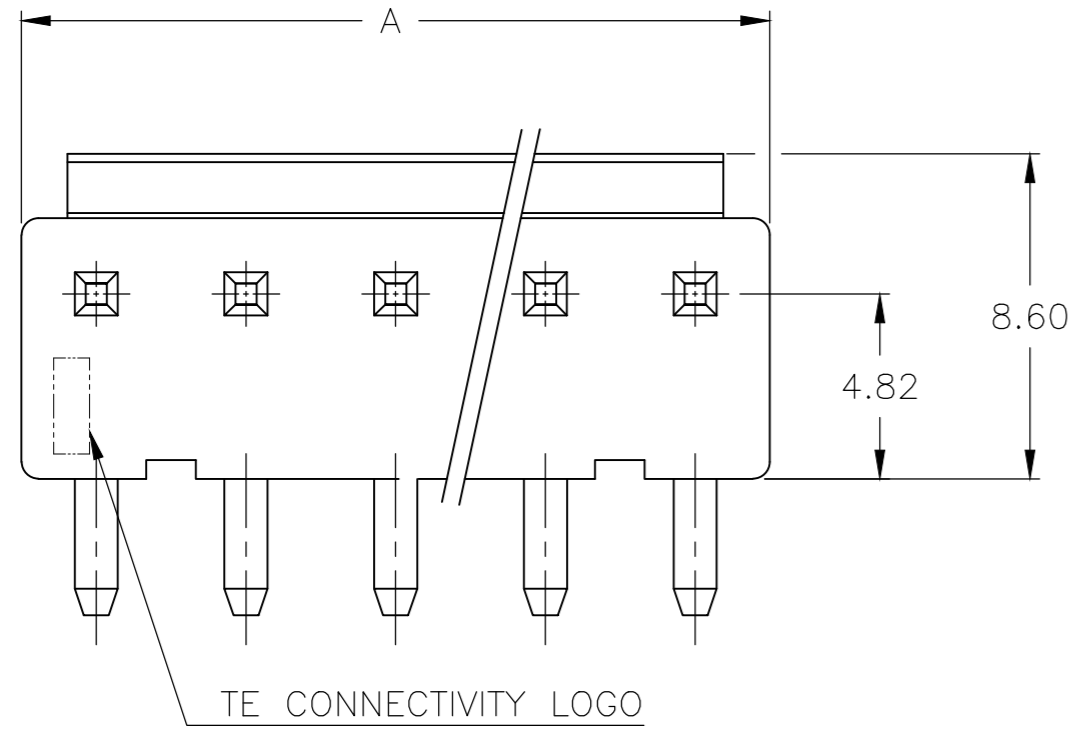

2,5	23.76	6	2-1744428-6
-	47.52	12	1-1744428-2
-	43.56	11	1-1744428-1
-	39.60	10	1-1744428-0
-	35.64	9	1744428-9
-	31.68	8	1744428-8
-	27.72	7	1744428-7
-	23.76	6	1744428-6
-	19.80	5	1744428-5
-	15.84	4	1744428-4
-	11.88	3	1744428-3
-	7.92	2	1744428-2
DIM. A	DIM. A	CIRCUITS	PART NUMBER

THIS DRAWING IS A CONTROLLED DOCUMENT.		DWN	JR RUTH	09JAN12	 TE Connectivity	
DIMENSIONS: mm		CHK	SAM MACE	09JAN12		
TOLERANCES UNLESS OTHERWISE SPECIFIED:		APVD	SAM MACE	09JAN12		
0 PLC ± - 1 PLC ± - 2 PLC ± 0.20 3 PLC ± - 4 PLC ± - ANGLES ± 30'		PRODUCT SPEC	108-5609	NAME		ASSEMBLY, EP HEADER, RIGHT ANGLE
MATERIAL	-	FINISH	-	WEIGHT	0.000000	
CUSTOMER DRAWING		SCALE	5:1	SHEET	1 of 1	
		SIZE	A2	CAGE CODE	00779	
		DRAWING NO	C=1744428		RESTRICTED TO	-
		REV	E1			