

Single-Turn Continuous Rotation Analog Displacement Sensors



FEATURES

- Conductive plastic potentiometer technology, infinite resolution 
- Metal housing
- Stainless steel shaft
- Precious metal contacts
- Soldering terminal outputs
- Dust proof
- Applicable standards: NFC 93255, MIL R39023
- Variant to be specify:
 - PP22 B: bush mounting, plain bearing self lubricating
 - PP22 S: servo mounting, plain bearing self lubricating
 - PP22 SR: servo mounting, precision ball bearing
- Material categorization: for definitions of compliance please see www.vishay.com/doc?99912

QUICK REFERENCE DATA

Sensor type	ROTATIONAL, conductive plastic
Output type	Output by turrets
Market appliance	Industrial, avionics
Dimensions	7/8" (22.2 mm)

ELECTRICAL SPECIFICATIONS

PARAMETER	
Total and useful electrical travel	340° ± 3°
Total and useful electrical travel (on request)	90° ± 2° (SR), 120° + 0° - 2° (SR)
Independent linearity standard	± 1.0 %
Independent linearity optional	B or S: ± 0.5 %, SR: ± 0.25 % and ± 0.2 %
Rated resistance range (R _n)	4.7 kΩ, 10 kΩ
Tolerance on R _n	± 20 %, ± 10 %, ± 5 % (on request)
Output smoothness	≤ 0.1 %
Power rating at 70 °C	1 W
Temperature coefficient	-200 ± 200 ppm/°C
Wiper current	≤ 1 mA
Insulation resistance	≥ 1 GΩ at 500 V _{CC}
Test voltage	750 V, 50 Hz, 1 min

MECHANICAL SPECIFICATIONS

PARAMETER	
Mechanical rotation	360° continuous
Starting and running torque	B or S: ≤ 0.5 N cm SR: ≤ 0.1 N cm
Starting torque (on request)	≥ 5 cN cm and ≤ 10 cN cm
Running torque (on request)	≥ 3.5 cN cm and ≤ 10 cN cm
Bush tightening torque (for bushing mount)	≤ 250 N cm
Moment of inertia	≤ 1 g cm ²
Weight	S or SR: < 13 g B: < 15 g

PERFORMANCE

PARAMETER	
Operating temperature range	-55 °C to +125 °C
Life	10M cycles; on request (to test in function of specific cycles) 20M cycles
Rotation speed (max.)	SR: 600 rpm S and B: 120 rpm



SAP PART NUMBERING GUIDELINES						
MODEL	MOUNTING	TYPE	VALUE	LINEARITY	ANGLE	PACKAGING
PP22	B = bushing	S = sleeve bearing	472 = 4.7K 103 = 10K	A = 1 % B = 0.5 %	340	B = box
	S = servo	R = ball bearing S = sleeve bearing				

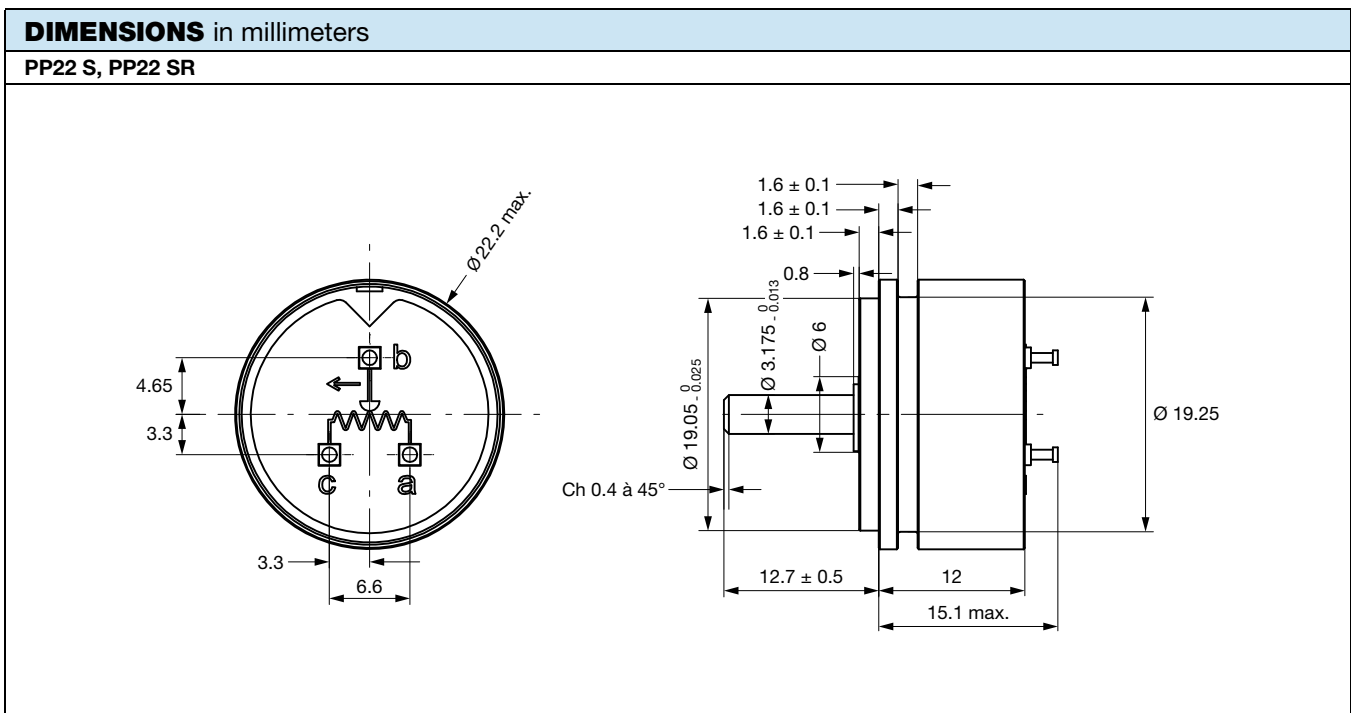
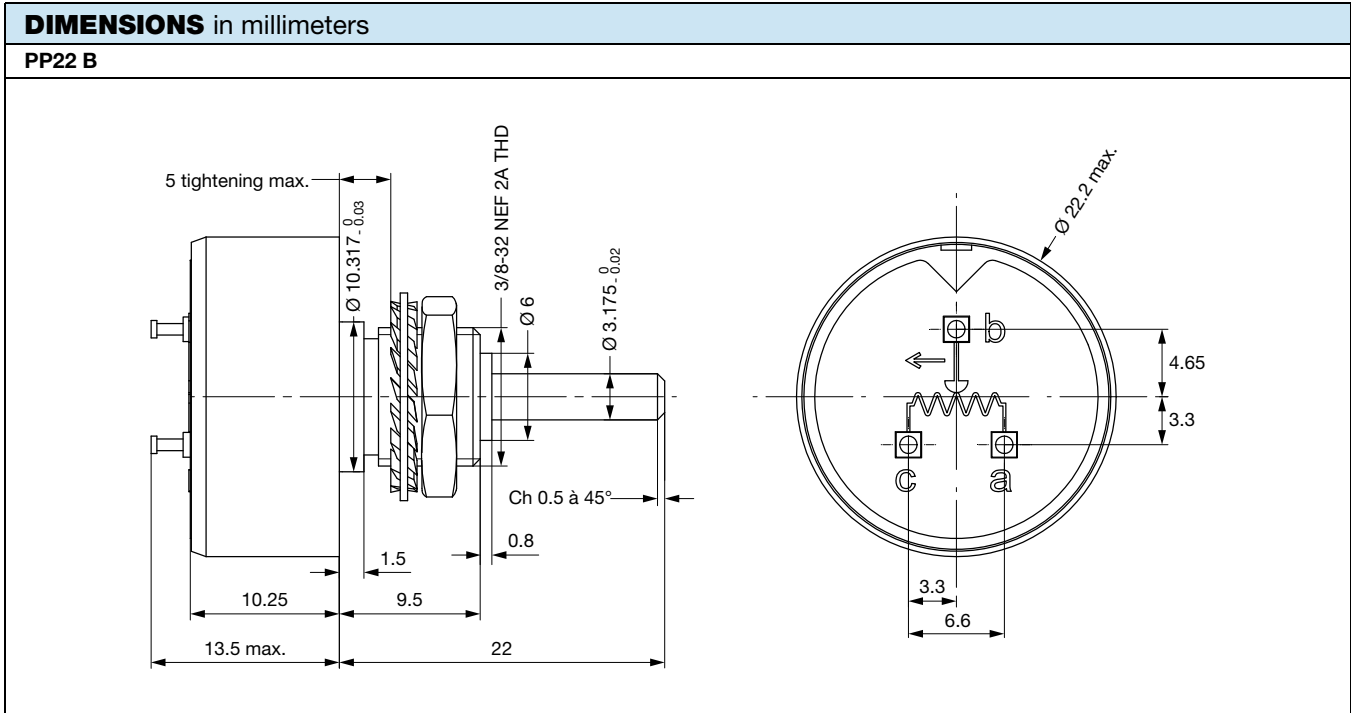

DIMENSIONS in millimeters		
PP22 S, PP22 SR ON REQUEST		
OPTION 1	OPTION 2	OPTION 3
		<p>Pinion: - module: 0.5 - tooth number: 36</p> <p>Marking housing / gear</p>
OPTION 4	OPTION 5	OPTION 6
	<p>Pinion: - module: 0.3 - tooth number: 19</p> <p>Marking housing / gear</p>	

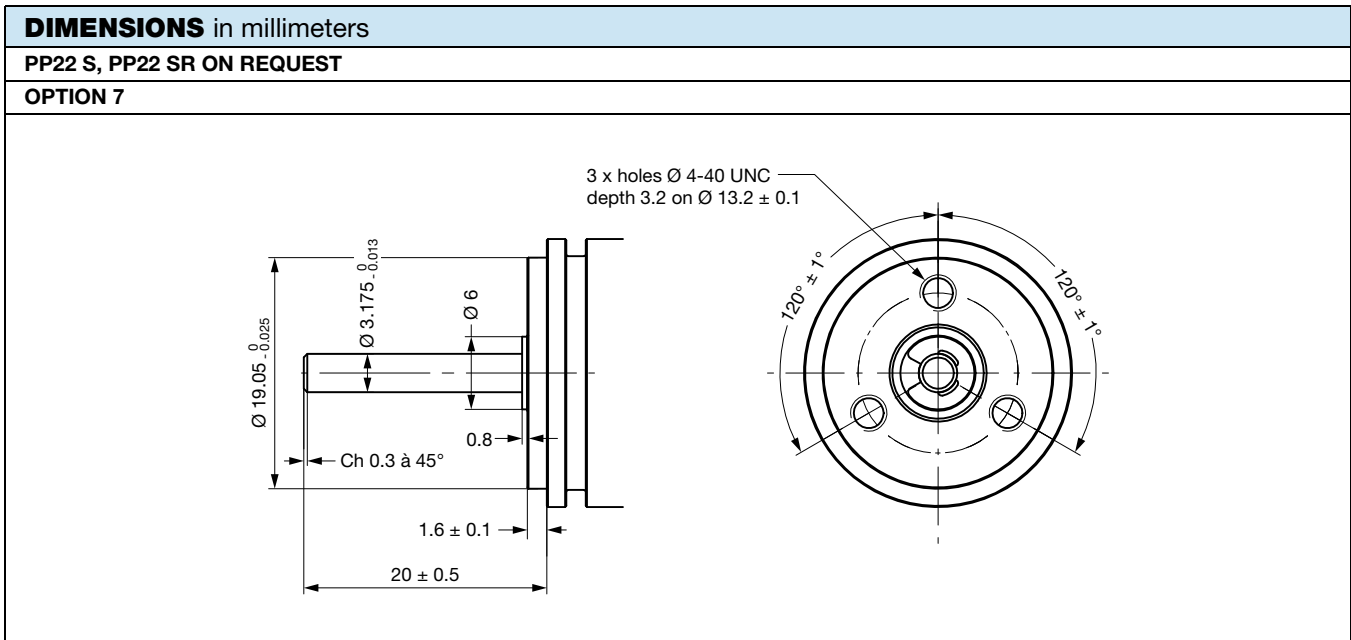

ELECTRICAL DIAGRAM

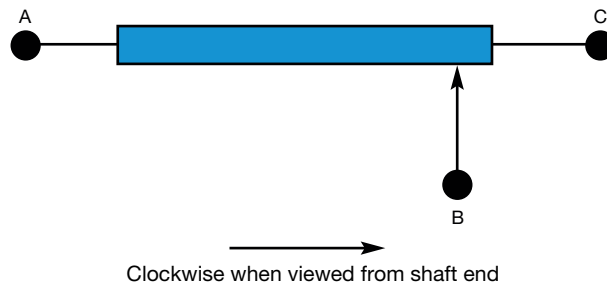

POWER RATING CHART

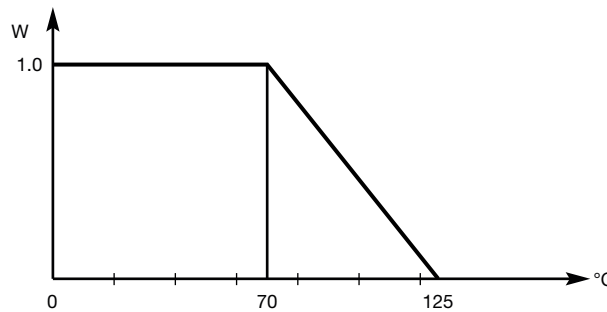

OPTIONS (on request)

- Other electrical travels: 345° (0°; + 2°); 345° ± 3° (SR), 72° ± 2°
- Other ohmic value: 1 k Ω , 2 k Ω , 5 k Ω , and 47 k Ω
- Other tolerances on R_n
- Other linearities (example: 0.9 %)
- Middle tap: 8° ± 1°
- Reinforced mechanical fixation on turrets and track to support big efforts (by gluing)
- Insulation resistance 10 G Ω - 500 V_{CC}



Disclaimer

ALL PRODUCT, PRODUCT SPECIFICATIONS AND DATA ARE SUBJECT TO CHANGE WITHOUT NOTICE TO IMPROVE RELIABILITY, FUNCTION OR DESIGN OR OTHERWISE.

Vishay Intertechnology, Inc., its affiliates, agents, and employees, and all persons acting on its or their behalf (collectively, "Vishay"), disclaim any and all liability for any errors, inaccuracies or incompleteness contained in any datasheet or in any other disclosure relating to any product.

Vishay makes no warranty, representation or guarantee regarding the suitability of the products for any particular purpose or the continuing production of any product. To the maximum extent permitted by applicable law, Vishay disclaims (i) any and all liability arising out of the application or use of any product, (ii) any and all liability, including without limitation special, consequential or incidental damages, and (iii) any and all implied warranties, including warranties of fitness for particular purpose, non-infringement and merchantability.

Statements regarding the suitability of products for certain types of applications are based on Vishay's knowledge of typical requirements that are often placed on Vishay products in generic applications. Such statements are not binding statements about the suitability of products for a particular application. It is the customer's responsibility to validate that a particular product with the properties described in the product specification is suitable for use in a particular application. Parameters provided in datasheets and / or specifications may vary in different applications and performance may vary over time. All operating parameters, including typical parameters, must be validated for each customer application by the customer's technical experts. Product specifications do not expand or otherwise modify Vishay's terms and conditions of purchase, including but not limited to the warranty expressed therein.

Hyperlinks included in this datasheet may direct users to third-party websites. These links are provided as a convenience and for informational purposes only. Inclusion of these hyperlinks does not constitute an endorsement or an approval by Vishay of any of the products, services or opinions of the corporation, organization or individual associated with the third-party website. Vishay disclaims any and all liability and bears no responsibility for the accuracy, legality or content of the third-party website or for that of subsequent links.

Except as expressly indicated in writing, Vishay products are not designed for use in medical, life-saving, or life-sustaining applications or for any other application in which the failure of the Vishay product could result in personal injury or death. Customers using or selling Vishay products not expressly indicated for use in such applications do so at their own risk. Please contact authorized Vishay personnel to obtain written terms and conditions regarding products designed for such applications.

No license, express or implied, by estoppel or otherwise, to any intellectual property rights is granted by this document or by any conduct of Vishay. Product names and markings noted herein may be trademarks of their respective owners.