

THIS DRAWING IS UNPUBLISHED. RELEASED FOR PUBLICATION
 © COPYRIGHT - A ALL RIGHTS RESERVED.

REVISIONS					
P	LTR	DESCRIPTION	DATE	DWN	APVD
	A1	REVISED PER ECR-16-015883	16NOV2016	RK	SS
	A2	REVISED PER ECR-16-017884	21DEC2016	RK	SS
	B	REVISED PER ECR-18-009447	16OCT2018	SR	PO

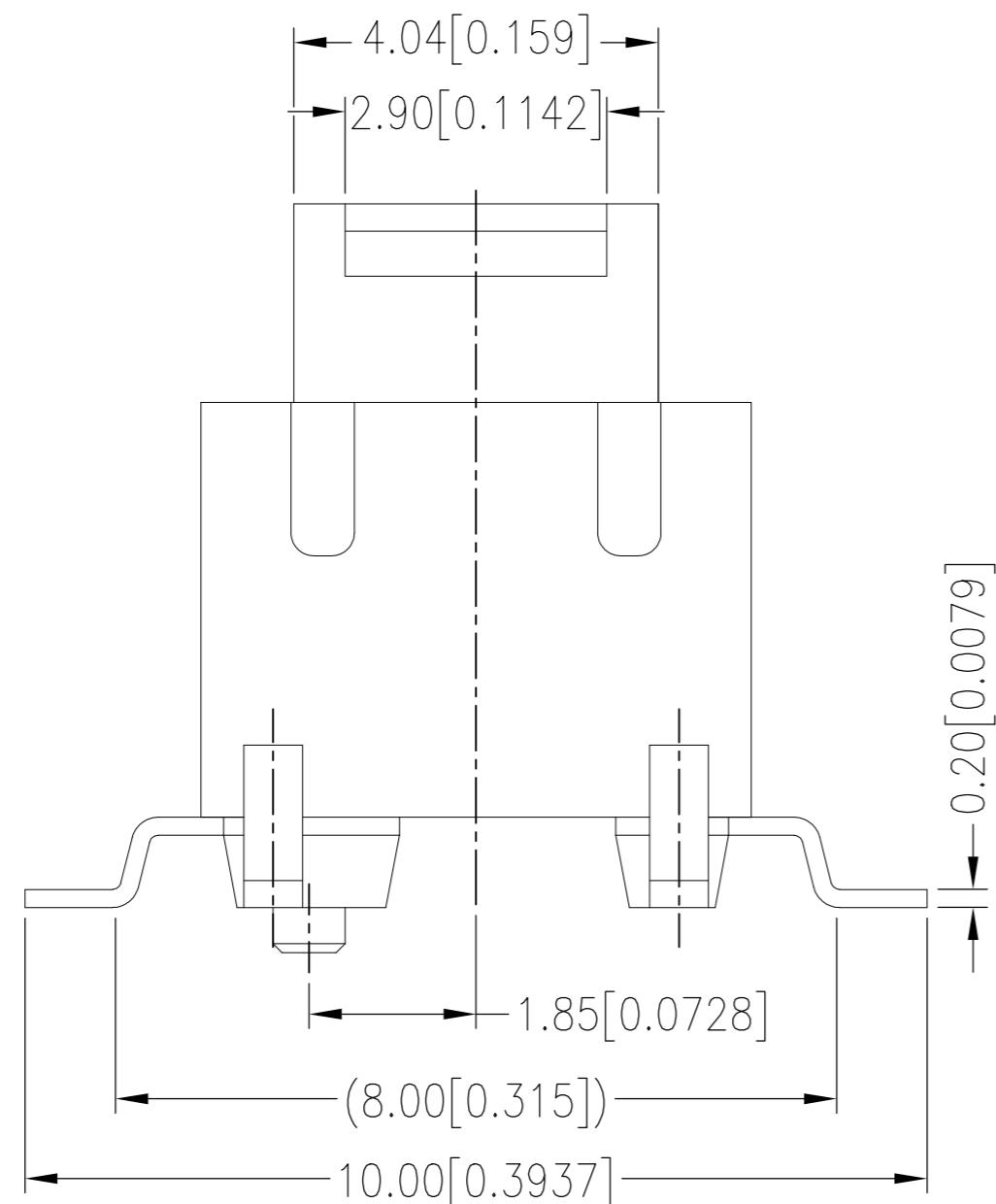

SPECIFICATIONS:

MATERIALS

CASE: HIGH TEMP THERMOPLASTIC (UL94-V0), BLACK
 ACTUATOR: HIGH TEMP THERMOPLASTIC PA9T (UL94-V0)
 MOXING CONTACT: STAINLESS STEEL, AG PLATED
 FIXED CONTACT/TERMINAL: BRASS, AG PLATED

ELECTRICAL

CONTACT RATING: 50 mA @ 12 VDC
 INITIAL CONTACT RESISTANCE: 100 MILLIOHMS MAX
 INSULATION RESISTANCE: 100 MEGAOHM MIN @ 500 VDC
 DIELECTRIC STRENGTH: 250 VAC FOR 1 MINUTE

MECHANICAL

ACTUATION FORCE: SEE TABLE
 ACTUATION TRAVEL: 0.20 MM +/- 0.10 MM
 ACTUATION CYCLES: FOR ACTUATION FORCE OF 100GF OR 160GF,
 500,000 ACTUATION CYCLES MIN; FOR ACTUATION FORCE OF 260GF
 OF 520GF, 200,000 ACTUATION CYCLES MIN

ENVIRONMENTAL

OPERATING TEMPERATURE: -25°C TO +70°C
 STORAGE TEMPERATURE: -30°C TO +80°C
 STORAGE HUMIDITY: 85% MAX
 VIBRATION: PER MIL-STD-202F, METHOD 201A
 THERMAL SHOCK: PER MIL-STD-202F, METHOD 213B, CONDITION A
 RESISTANCE TO SOLDER HEAT: REFLOW SOLDERING TEMPERATURE
 260°C +/- 5°C PER TEC-109-201, CONDITION B

1. ALL MATERIALS AND FINISHES SHALL COMPLY WITH EU DIRECTIVE 2002/95/EC OF 27JAN2003 (ROHS).
2. LOW INTENSITY LED PARTS SHOWN ON PAGE 2
3. HIGH INTENSITY LED PARTS SHOWN ON PAGE 3
4. PARTS TO BE PACKAGED IN TAPE AND REEL AND CARTON. REEL AND CARTON TO INCLUDE CAUTION STATIC SENSITIVE DEVICE LABELS. PER EIA-481.
5. IF THIS SWITCH IS USED WITH A CAP, THE CAP SHALL BE INSTALLED AFTER SOLDERING THE SWITCH TO PCB.

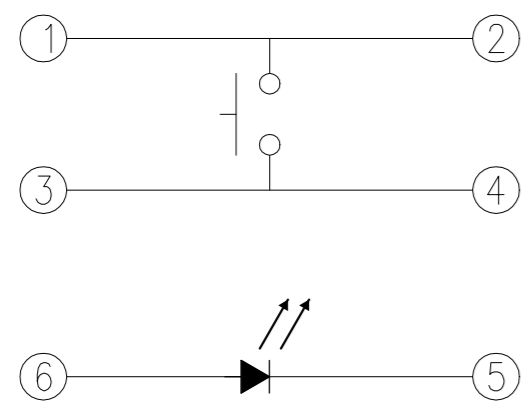

CIRCUIT DIAGRAM

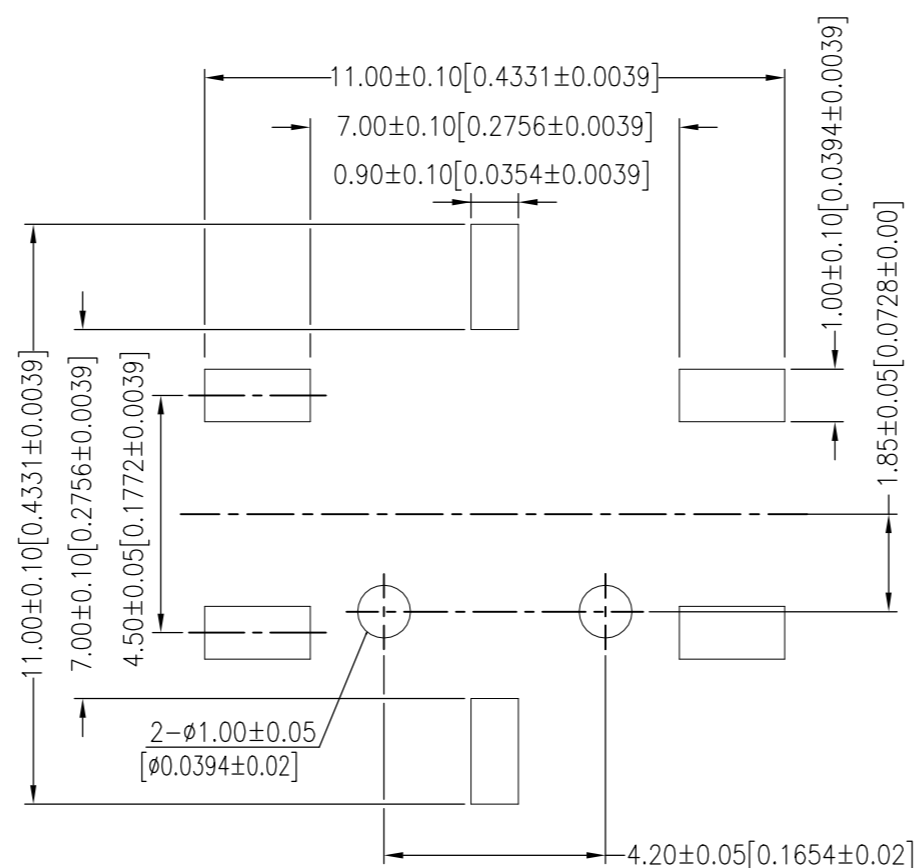

P.C.B. LAYOUT

THIS DRAWING IS A CONTROLLED DOCUMENT.		DWN RAVLS 16MAR2016	TE Connectivity	
DIMENSIONS: mm		CHK R. Hill 16MAR2016		
TOLERANCES UNLESS OTHERWISE SPECIFIED:		APVD R. Hill 16MAR2016	NAME ILLUMINATED TACTILE SWITCH SURFACE MOUNTED	
0 PLC ± - 1 PLC ± - 2 PLC ± +/- 0.30 3 PLC ± - 4 PLC ± - ANGLES ± -		PRODUCT SPEC APPLICATION SPEC	SIZE A2	
MATERIAL -		FINISH -	CAGE CODE 00779	DRAWING NO 2213819
		WEIGHT	RESTRICTED TO -	SCALE 1:1
		CUSTOMER DRAWING	SHEET 1 of 3	REV B

4

3

2

1

THIS DRAWING IS UNPUBLISHED. RELEASED FOR PUBLICATION. ALL RIGHTS RESERVED. © COPYRIGHT - A

REVISIONS				
P	LTR	DESCRIPTION	DATE	APVD
-	-	SEE SHEET 1	-	-

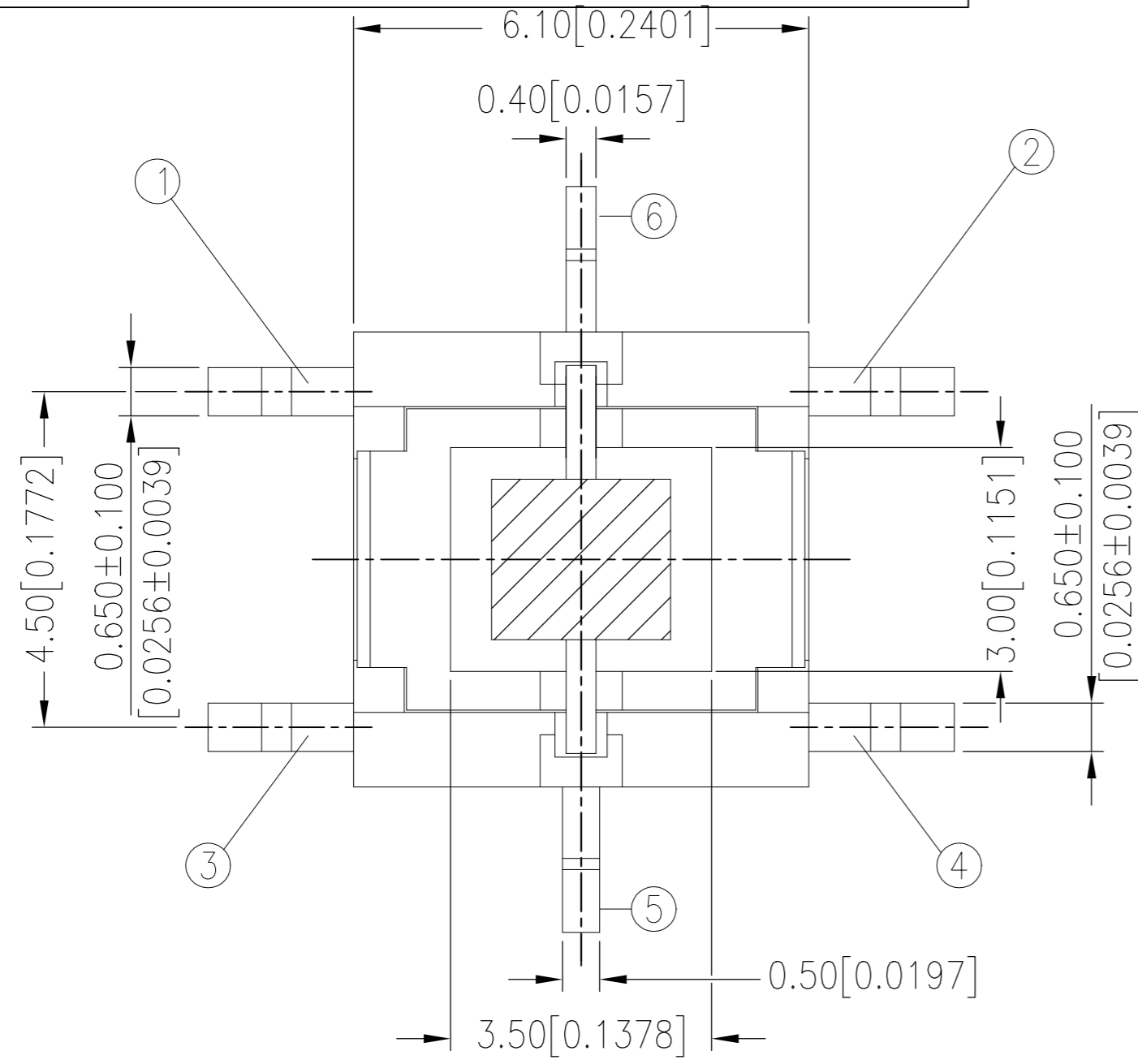

LOW INTENSITY LED PROFILE

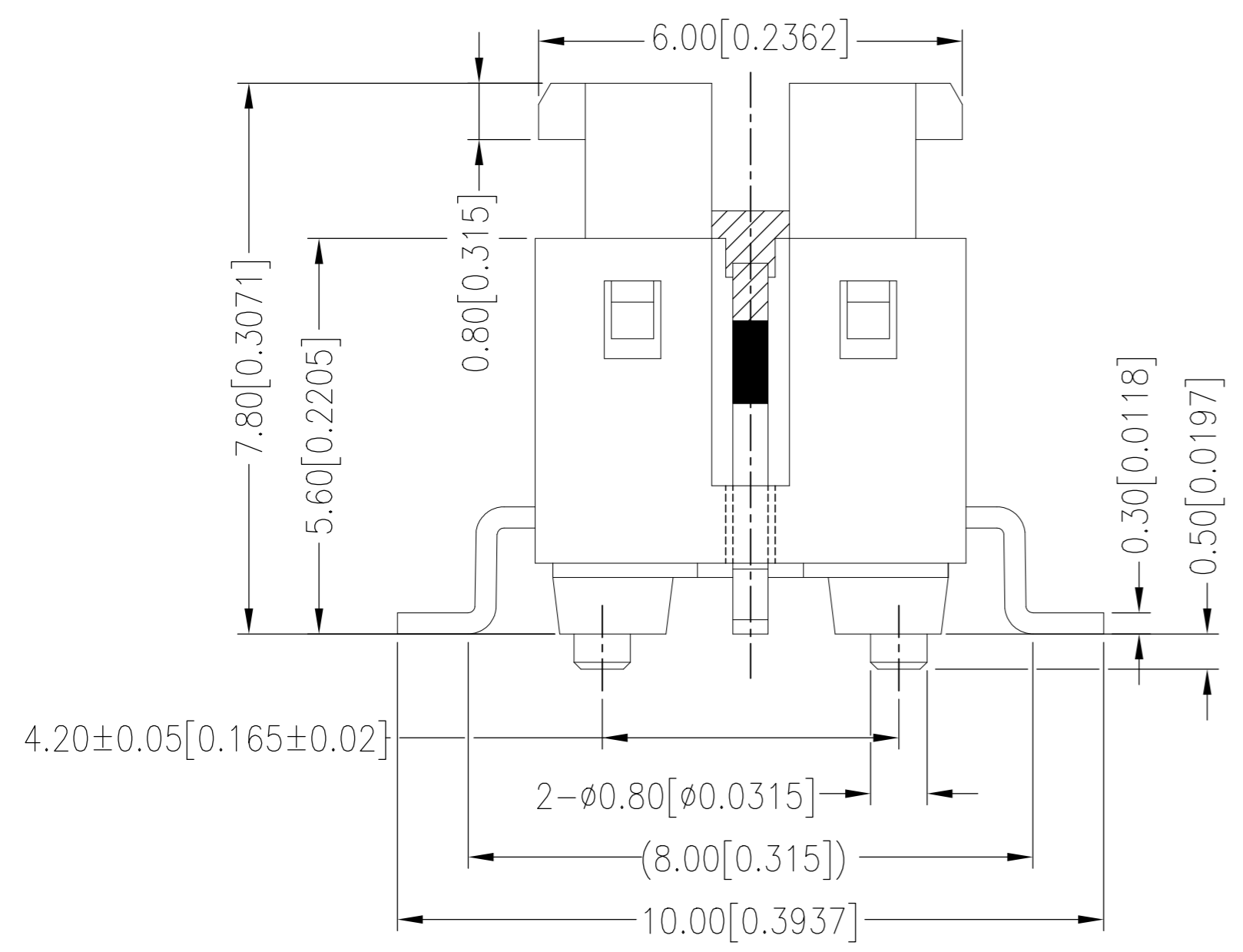

520	COLD WHITE	FSMIJM65AW04	5-2213819-6
520	RED	FSMIJM65AR04	5-2213819-5
520	RED ORANGE	FSMIJM65A004	5-2213819-4
520	SOFT ORANGE	FSMIJM65AA04	5-2213819-3
520	YELLOW	FSMIJM65AY04	5-2213819-2
520	YELLOW GREEN	FSMIJM65AG04	5-2213819-1
520	PURE GREEN	FSMIJM65APG04	5-2213819-0
520	BLUE	FSMIJM65AB04	4-2213819-9
260	COLD WHITE	FSMIJM63AW04	4-2213819-0
260	RED	FSMIJM63AR04	3-2213819-9
260	RED ORANGE	FSMIJM63A004	3-2213819-8
260	SOFT ORANGE	FSMIJM63AA04	3-2213819-7
260	YELLOW	FSMIJM63AY04	3-2213819-6
260	YELLOW GREEN	FSMIJM63AG04	3-2213819-5
260	PURE GREEN	FSMIJM63APG04	3-2213819-4
260	BLUE	FSMIJM63AB04	3-2213819-3
160	COLD WHITE	FSMIJM62AW04	2-2213819-4
160	RED	FSMIJM62AR04	2-2213819-3
160	RED ORANGE	FSMIJM62A004	2-2213819-2
160	SOFT ORANGE	FSMIJM62AA04	2-2213819-1
160	YELLOW	FSMIJM62AY04	2-2213819-0
160	YELLOW GREEN	FSMIJM62AG04	1-2213819-9
160	PURE GREEN	FSMIJM62APG04	1-2213819-8
160	BLUE	FSMIJM62AB04	1-2213819-7
100	COLD WHITE	FSMIJM61AW04	2213819-8
100	RED	FSMIJM61AR04	2213819-7
100	RED ORANGE	FSMIJM61A004	2213819-6
100	SOFT ORANGE	FSMIJM61AA04	2213819-5
100	YELLOW	FSMIJM61AY04	2213819-4
100	YELLOW GREEN	FSMIJM61AG04	2213819-3
100	PURE GREEN	FSMIJM61APG04	2213819-2
100	BLUE	FSMIJM61AB04	2213819-1
OPERATING FORCE	LED COLOR	TE DESCRIPTIVE PART NUMBER	TE PART NUMBER

THIS DRAWING IS A CONTROLLED DOCUMENT.		DWN RAVLS 16MAR2016	TE TE Connectivity	
DIMENSIONS: mm		CHK R. Hill 16MAR2016		
TOLERANCES UNLESS OTHERWISE SPECIFIED:		APVD R. Hill 16MAR2016	NAME	
0 PLC ± -		PRODUCT SPEC		
1 PLC ± -		APPLICATION SPEC		
2 PLC ± -		WEIGHT		
3 PLC ± -		SIZE CAGE CODE DRAWING NO RESTRICTED TO		
4 PLC ± -		A2 00779 C=2213819 -		
ANGLES ± -		CUSTOMER DRAWING SCALE 1:1 SHEET 2 of 3 REV B		
FINISH				

THIS DRAWING IS UNPUBLISHED. RELEASED FOR PUBLICATION
 © COPYRIGHT - A ALL RIGHTS RESERVED.

REVISIONS					
P	LTR	DESCRIPTION	DATE	DWN	APVD
-	-	SEE SHEET 1	-	-	-

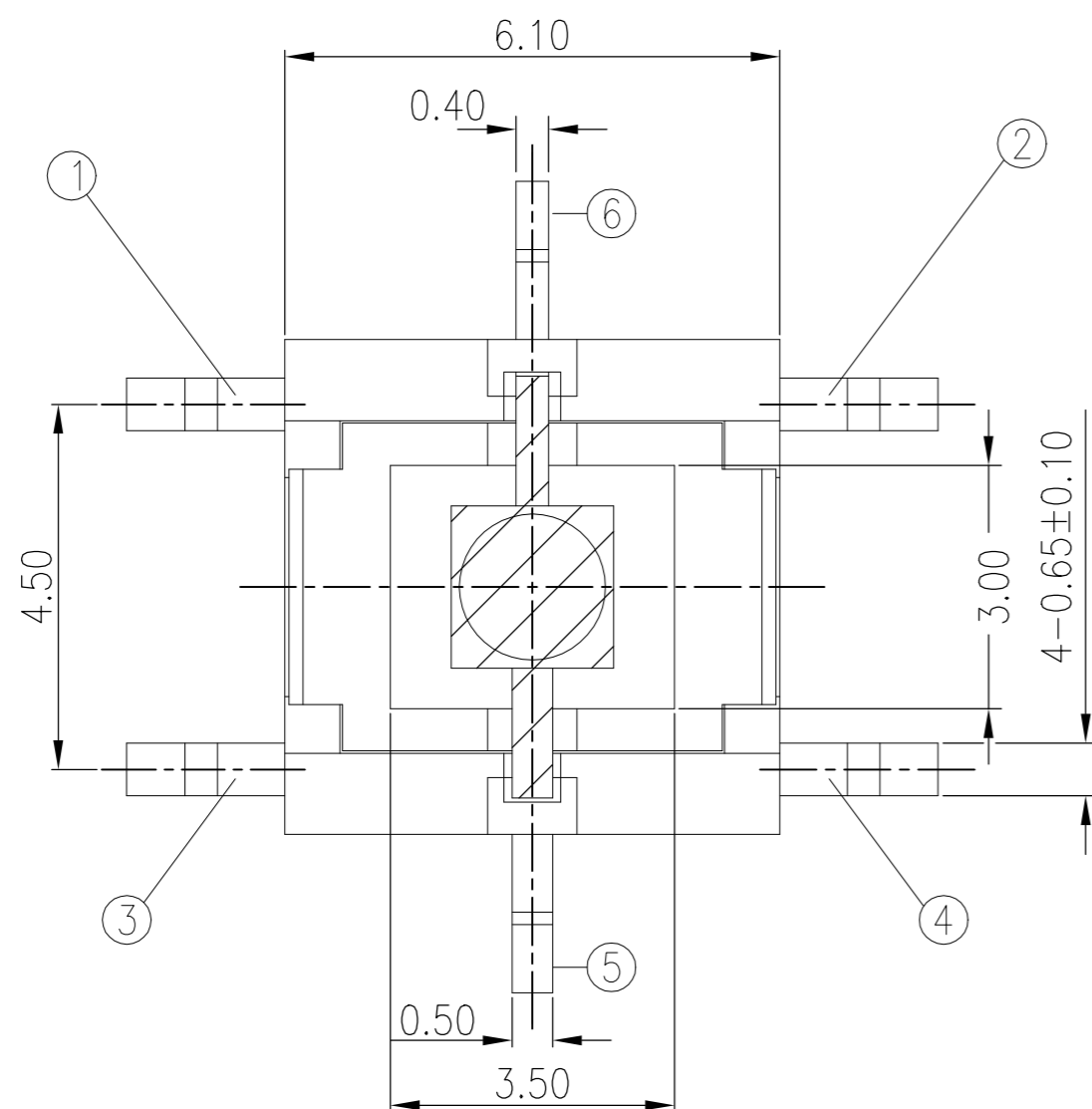

HIGH INTENSITY LED PROFILE

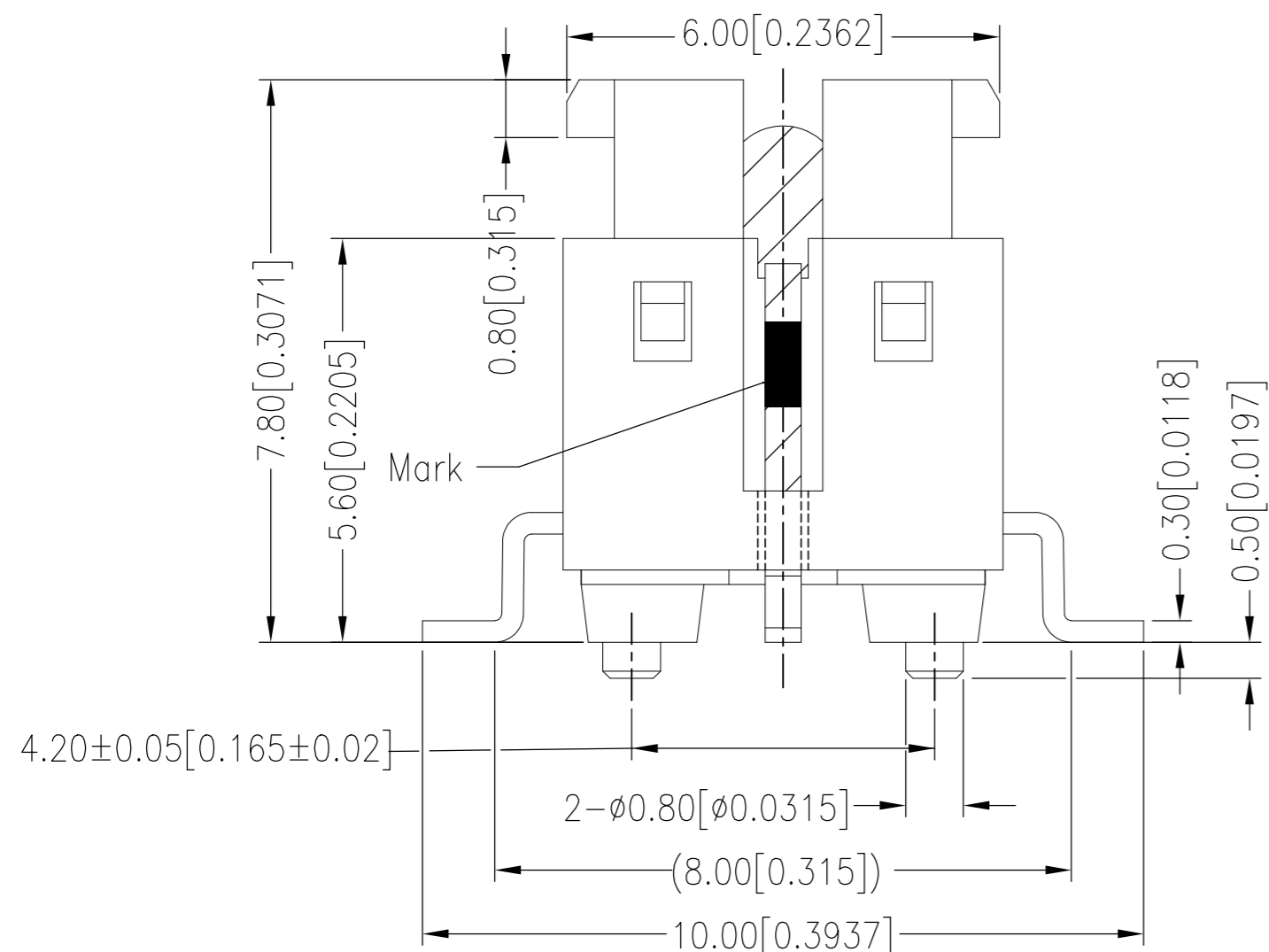

520	COLD WHITE	FSMIJM65BW04	6-2213819-4
520	RED	FSMIJM65BR04	6-2213819-3
520	RED ORANGE	FSMIJM65B004	6-2213819-2
520	SOFT ORANGE	FSMIJM65BA04	6-2213819-1
520	YELLOW	FSMIJM65BY04	6-2213819-0
520	YELLOW GREEN	FSMIJM65BG04	5-2213819-9
520	PURE GREEN	FSMIJM65BPG04	5-2213819-8
520	BLUE	FSMIJM65BB04	5-2213819-7
260	COLD WHITE	FSMIJM63BW04	4-2213819-8
260	RED	FSMIJM63BR04	4-2213819-7
260	RED ORANGE	FSMIJM63B004	4-2213819-6
260	SOFT ORANGE	FSMIJM63BA04	4-2213819-5
260	YELLOW	FSMIJM63BY04	4-2213819-4
260	YELLOW GREEN	FSMIJM63BG04	4-2213819-3
260	PURE GREEN	FSMIJM63BPG04	4-2213819-2
260	BLUE	FSMIJM63BB04	4-2213819-1
160	COLD WHITE	FSMIJM62BW04	3-2213819-2
160	RED	FSMIJM62BR04	3-2213819-1
160	RED ORANGE	FSMIJM62B004	3-2213819-0
160	SOFT ORANGE	FSMIJM62BA04	2-2213819-9
160	YELLOW	FSMIJM62BY04	2-2213819-8
160	YELLOW GREEN	FSMIJM62BG04	2-2213819-7
160	PURE GREEN	FSMIJM62BPG04	2-2213819-6
160	BLUE	FSMIJM62BB04	2-2213819-5
100	COLD WHITE	FSMIJM61BW04	1-2213819-6
100	RED	FSMIJM61BR04	1-2213819-5
100	RED ORANGE	FSMIJM61B004	1-2213819-4
100	SOFT ORANGE	FSMIJM61BA04	1-2213819-3
100	YELLOW	FSMIJM61BY04	1-2213819-2
100	YELLOW GREEN	FSMIJM61BG04	1-2213819-1
100	PURE GREEN	FSMIJM61BPG04	1-2213819-0
100	BLUE	FSMIJM61BB04	2213819-9
OPERATING FORCE	LED COLOR	TE DESCRIPTIVE PART NUMBER	TE PART NUMBER

THIS DRAWING IS A CONTROLLED DOCUMENT.		DWN RAVLS 16MAR2016	TE Connectivity	
DIMENSIONS: mm		CHK R. Hill 16MAR2016		
TOLERANCES UNLESS OTHERWISE SPECIFIED:		APVD R. Hill 16MAR2016	NAME ILLUMINATED TACTILE SWITCH SURFACE MOUNTED	
0 PLC ± - 1 PLC ± - 2 PLC ± +/- 0.30 3 PLC ± - 4 PLC ± - ANGLES ± -		PRODUCT SPEC	SIZE A2	
MATERIAL		APPLICATION SPEC	CAGE CODE 00779	DRAWING NO 2213819
FINISH		WEIGHT	SCALE 1:1	SHEET 3 of 3
		CUSTOMER DRAWING	RESTRICTED TO	REV B