

10091831 - X X X X X L F

LEAD-FREE DESIGNATION ADDED ONLY WHEN APPLICABLE

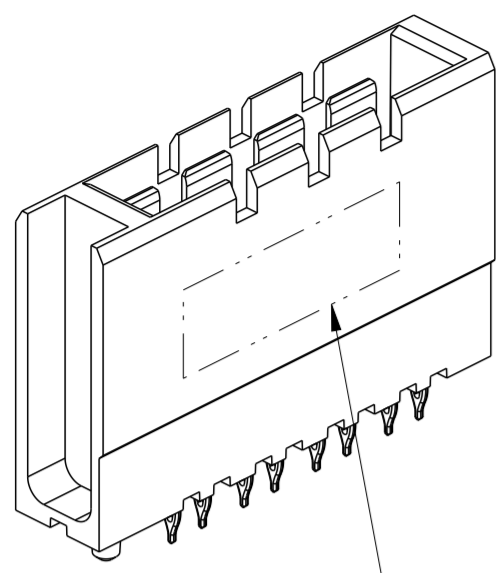

PLATING CODE	
I	SEPARABLE INTERFACE: PERFORMANCE-BASED PLATING, TELCORDIA CO (SEE NOTE 2) PRESS-FIT TAIL: TIN OR TIN-LEAD BASED ON LEAD-FREE "LF" SUFFIX
5	SEPARABLE INTERFACE: PERFORMANCE-BASED PLATING, TELCORDIA UE (SEE NOTE 2) PRESS-FIT TAIL: TIN OR TIN-LEAD ON BASED ON LEAD-FREE "LF" SUFFIX
D	SEPARABLE INTERFACE: CUSTOMER SPECIFIC PLATING PRESS-FIT TAIL: TIN OR TIN-LEAD ON BASED ON LEAD-FREE "LF" SUFFIX
E	SEPARABLE INTERFACE: CUSTOMER SPECIFIC PLATING PRESS-FIT TAIL: TIN OR TIN-LEAD ON BASED ON LEAD-FREE "LF" SUFFIX

SEQUENTIALLY ASSIGNED FOR CUSTOM LOADING CONFIGURATIONS (SEE TABLE, SHEET 5)
"00" FOR STANDARD LOADING (UNIFORM CONTACT LENGTH, ALL POSITIONS)

CONTACT WIPE LENGTH	
0	CUSTOM LOADED CONTACTS
1	4.5mm ALL CONTACTS
2	6.0mm ALL CONTACTS
3	7.5mm ALL CONTACTS

NUMBER OF POWER SLOTS	
1	ONE POWER SLOT ("1-UP" MODULE)
2	TWO POWER SLOTS ("2-UP" MODULE)
3	THREE POWER SLOTS ("3-UP" MODULE)

SCALE 3:1

SEE NOTE 11

BLADE POSITION A1 HAS TWO COMPLIANT TAILS, A1-1 AND A1-2 TYPICAL ALL POSITIONS

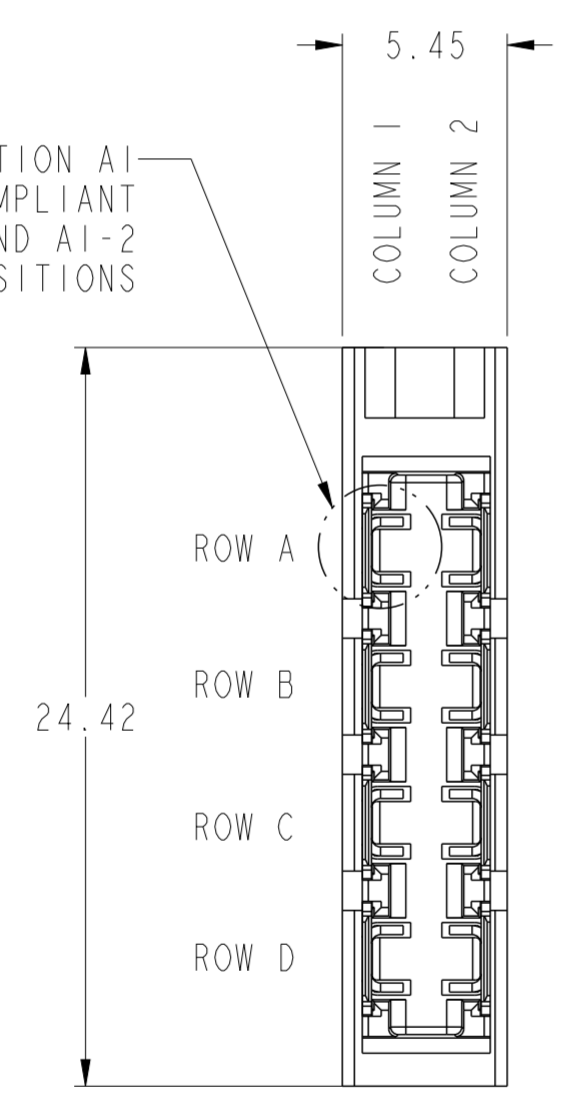

1-SLOT POWER MODULE MATING-FACE VIEW

SCALE 4:1

POSITION A1

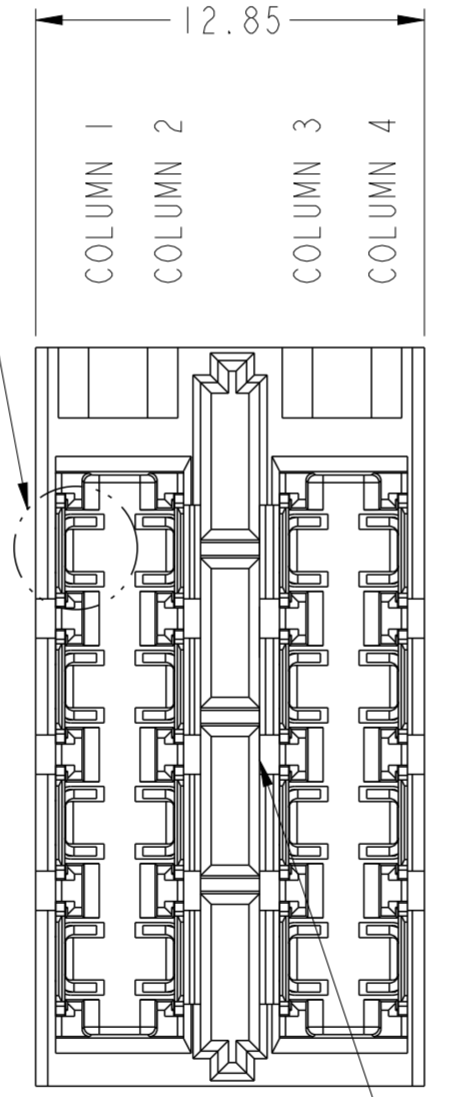

2-SLOT POWER MODULE MATING-FACE VIEW

SCALE 4:1

POSITION A1

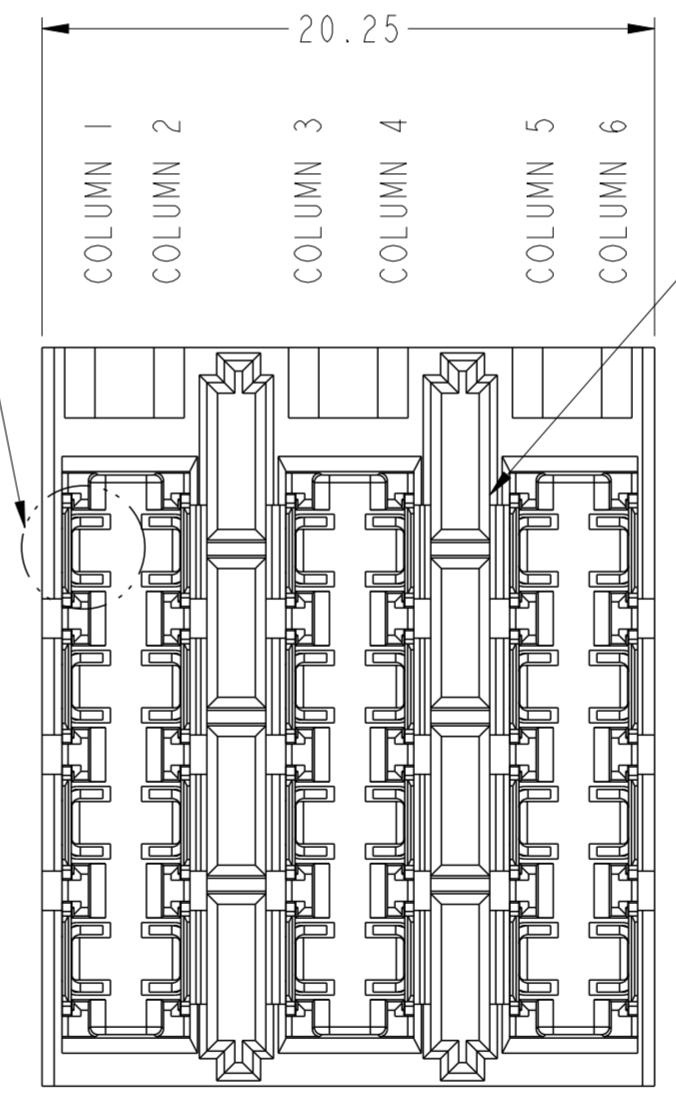

3-SLOT POWER MODULE MATING-FACE VIEW

SCALE 4:1

ENDCAP SLOT 2X SEE NOTE 5

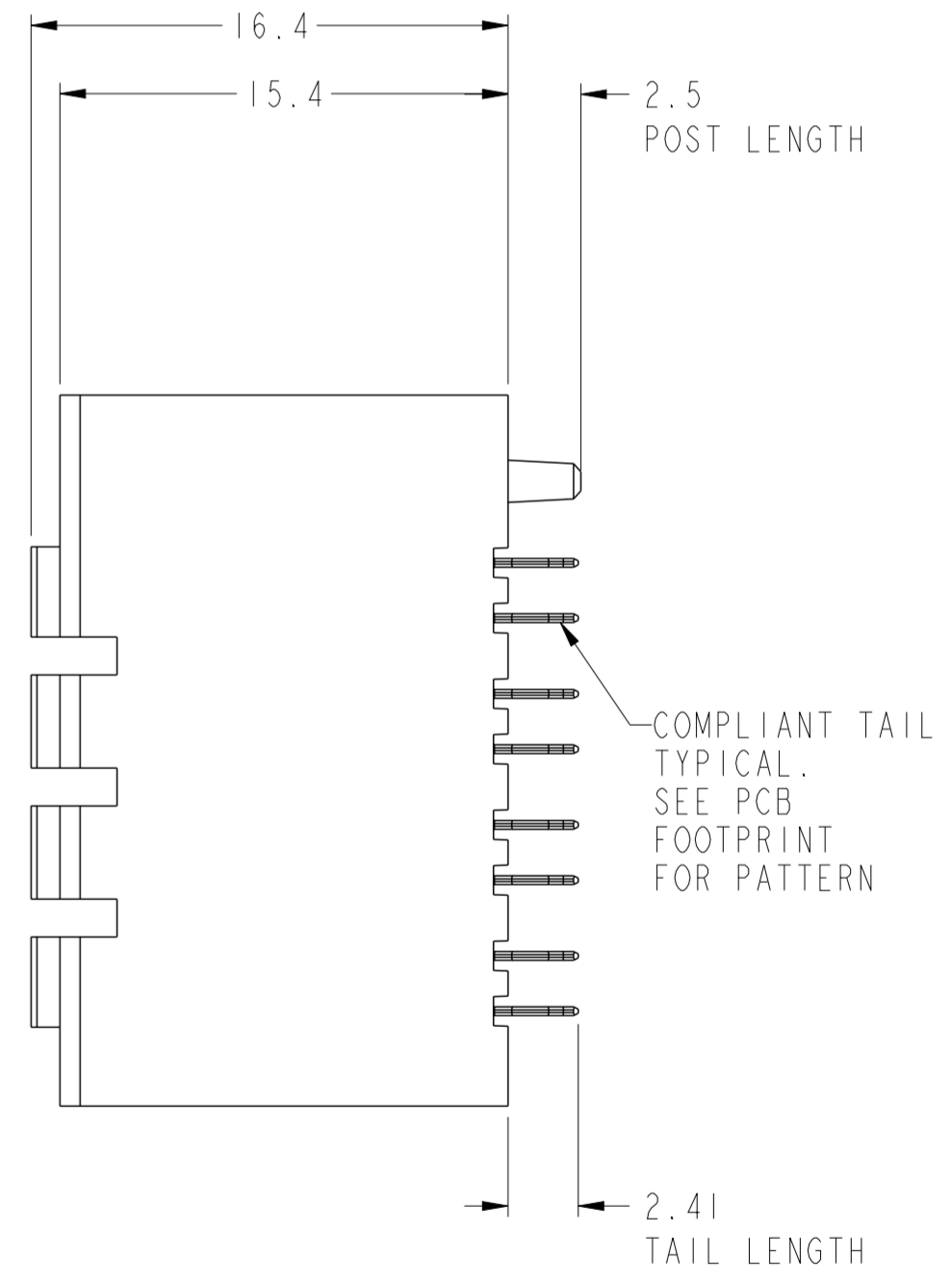

POWER MODULE GEOMETRY SHOWN IN DRAWING VIEWS IS SIMPLIFIED



Copyright FCI.

spec ref	SEE NOTES	dr	Jim Swain	2010/02/02	projection	mm	size	A2	scale	4:1									
tolerance std	TOLERANCES UNLESS OTHERWISE SPECIFIED	eng	Lin-Soe Ngwe	2012/11/19			ecn no	-	rel level	Released									
ASME Y14.5		chr	-	appr							Chen-Hong Tan	2012/11/19							
surface	<table border="1"> <tr> <td>linear</td> <td>0.X</td> <td>±0.25</td> </tr> <tr> <td></td> <td>0.XX</td> <td>±0.13</td> </tr> <tr> <td></td> <td>0.XXX</td> <td>±</td> </tr> <tr> <td>angular</td> <td>0°</td> <td>±°</td> </tr> </table>	linear	0.X	±0.25		0.XX	±0.13		0.XXX	±	angular	0°	±°			title MODULE ASSEMBLY, POWER XCede 4-PAIR VERTICAL, LOW PROFILE LESS IMM HEIGHT		dwg no 10091831	rev A
linear	0.X	±0.25																	
	0.XX	±0.13																	
	0.XXX	±																	
angular	0°	±°																	
ASME Y14.5		www.fci.com		cat. no.	Product - Customer Drw		sheet 1 of 5												

PDS: Rev :A

STATUS:Released

Printed: Nov 20, 2012

TABLE 1. VARIABLE FOOTPRINT DIMENSIONS

	DIM A	DIM B	DIM C	DIM D
1-SLOT POWER MODULE	7.40	4.81	12.21	6.66
2-SLOT POWER MODULE	14.80	12.21	19.61	14.06
3-SLOT POWER MODULE	22.20	19.61	27.01	21.46

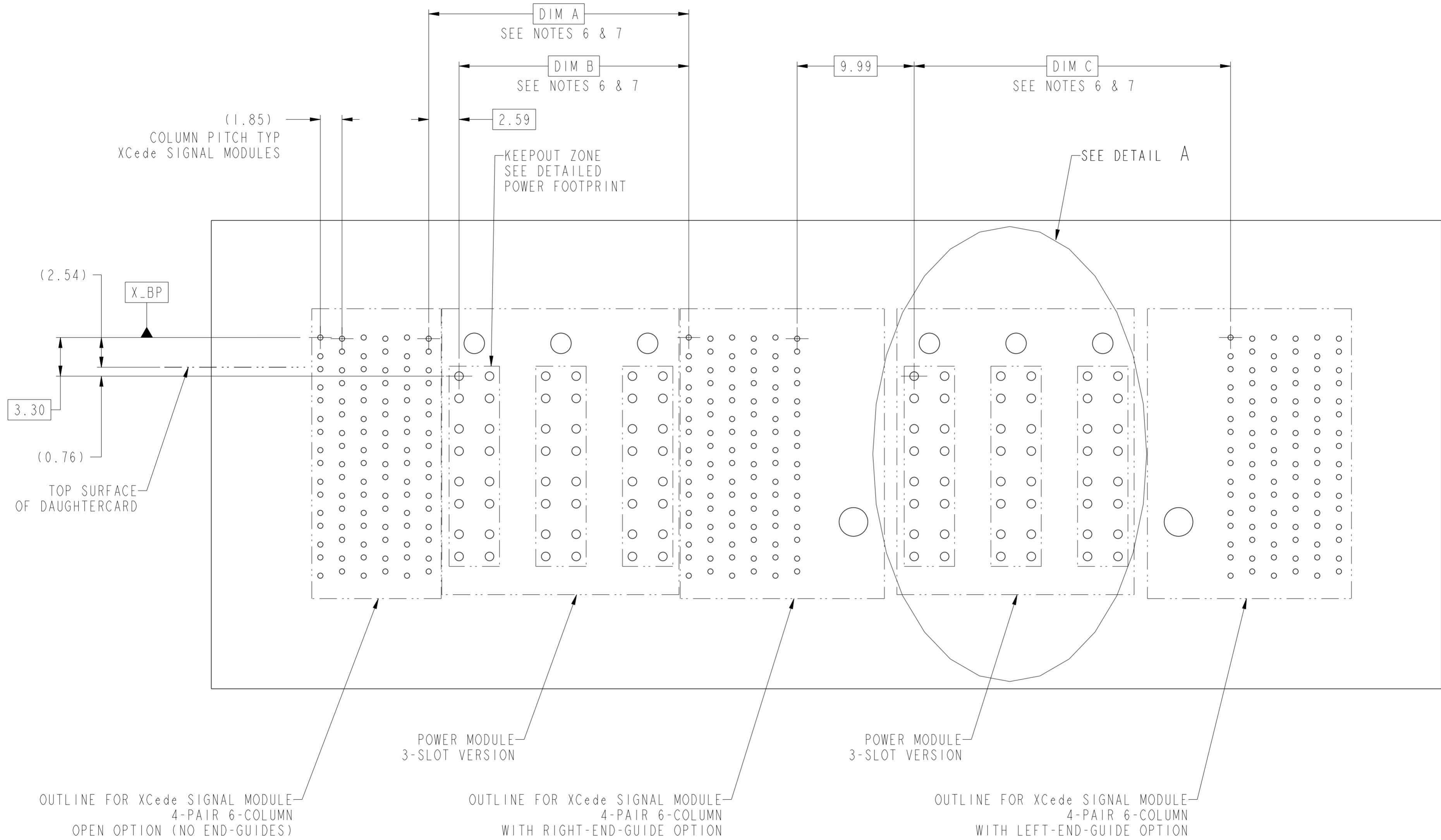

POWER MODULE FOOTPRINT LOCATION RELATIVE TO XCede SIGNAL MODULES

spec ref	SEE NOTES	dr	Jim Swain	2010/02/02	projection	mm	size	A2	scale	4:1
tolerance std	ASME Y14.5	eng	Lin-Soe Ngwe	2012/11/19	chr	-	ecn no	-	rel level	Released
surface	linear	appr	Chen-Hong Tan	2012/11/19	product family		cat. no.	10091831	rev	A
ASME Y14.5	angular	0°	±°	0.X	±0.25	0.XX	±0.13	0.XXX	±-	

SEE TABLE 1.

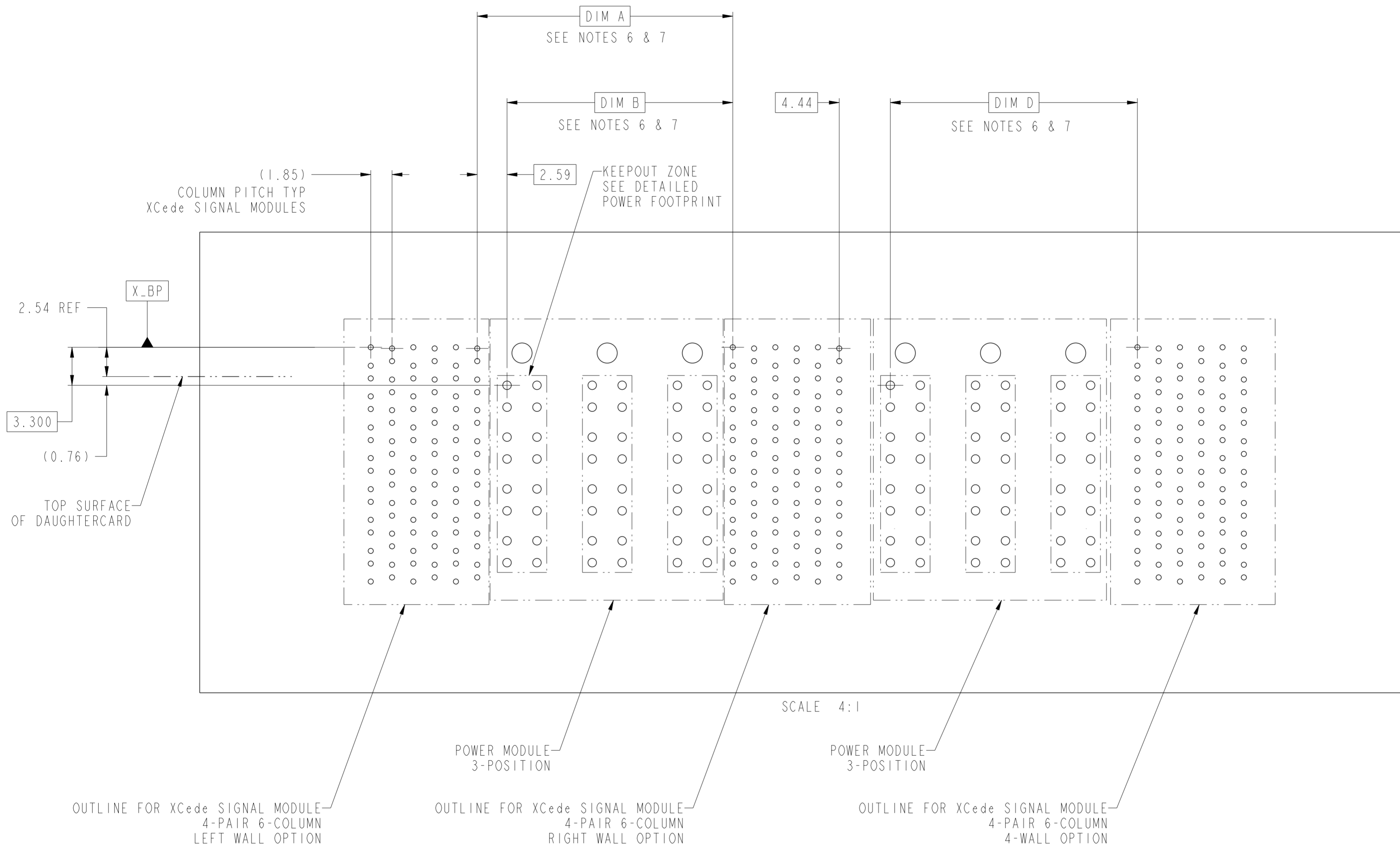

POWER MODULE FOOTPRINT LOCATION RELATIVE TO XCede SIGNAL MODULES

spec ref	SEE NOTES	dr	Jim Swain	2010/02/02	projection	mm	size	A2	scale	4:1									
tolerance std	TOLERANCES UNLESS OTHERWISE SPECIFIED	eng	Lin-Soe Ngwe	2012/11/19			ecn no	-	rel level	Released									
ASME Y14.5		chr	-	2012/11/19			product family												
surface	linear	appr	Chen-Hong Tan	2012/11/19			<table border="1"> <tr> <td>title</td> <td>MODULE ASSEMBLY, POWER</td> <td>dwg no</td> <td>10091831</td> <td>rev</td> <td>A</td> </tr> <tr> <td colspan="2">XCede 4-PAIR VERTICAL, LOW PROFILE LESS IMM HEIGHT</td> <td>cat. no.</td> <td>Product - Customer Drw</td> <td colspan="2">sheet 3 of 5</td> </tr> </table>	title	MODULE ASSEMBLY, POWER	dwg no	10091831	rev	A	XCede 4-PAIR VERTICAL, LOW PROFILE LESS IMM HEIGHT		cat. no.	Product - Customer Drw	sheet 3 of 5	
title	MODULE ASSEMBLY, POWER	dwg no	10091831	rev	A														
XCede 4-PAIR VERTICAL, LOW PROFILE LESS IMM HEIGHT		cat. no.	Product - Customer Drw	sheet 3 of 5															
ASME Y14.5	angular	0°	±0.25	±0.13	±-	±°													

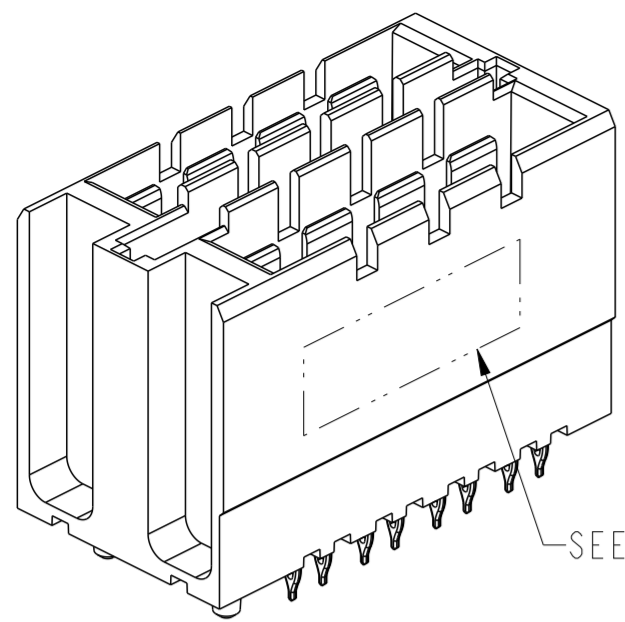

ISOMETRIC VIEW
2 POSITION
SCALE 3:1

SEE NOTE 11

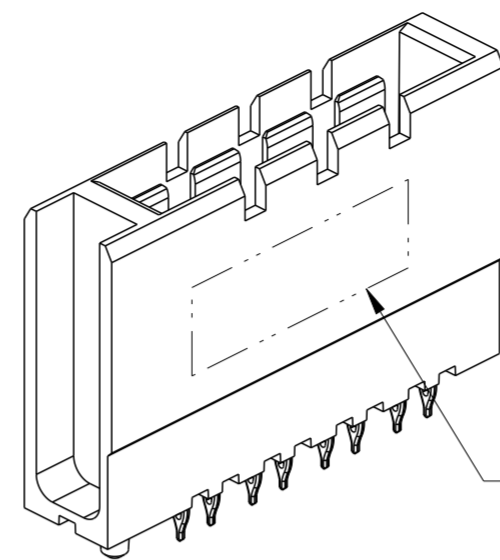

ISOMETRIC VIEW
1 POSITION
SCALE 3:1

SEE NOTE 11

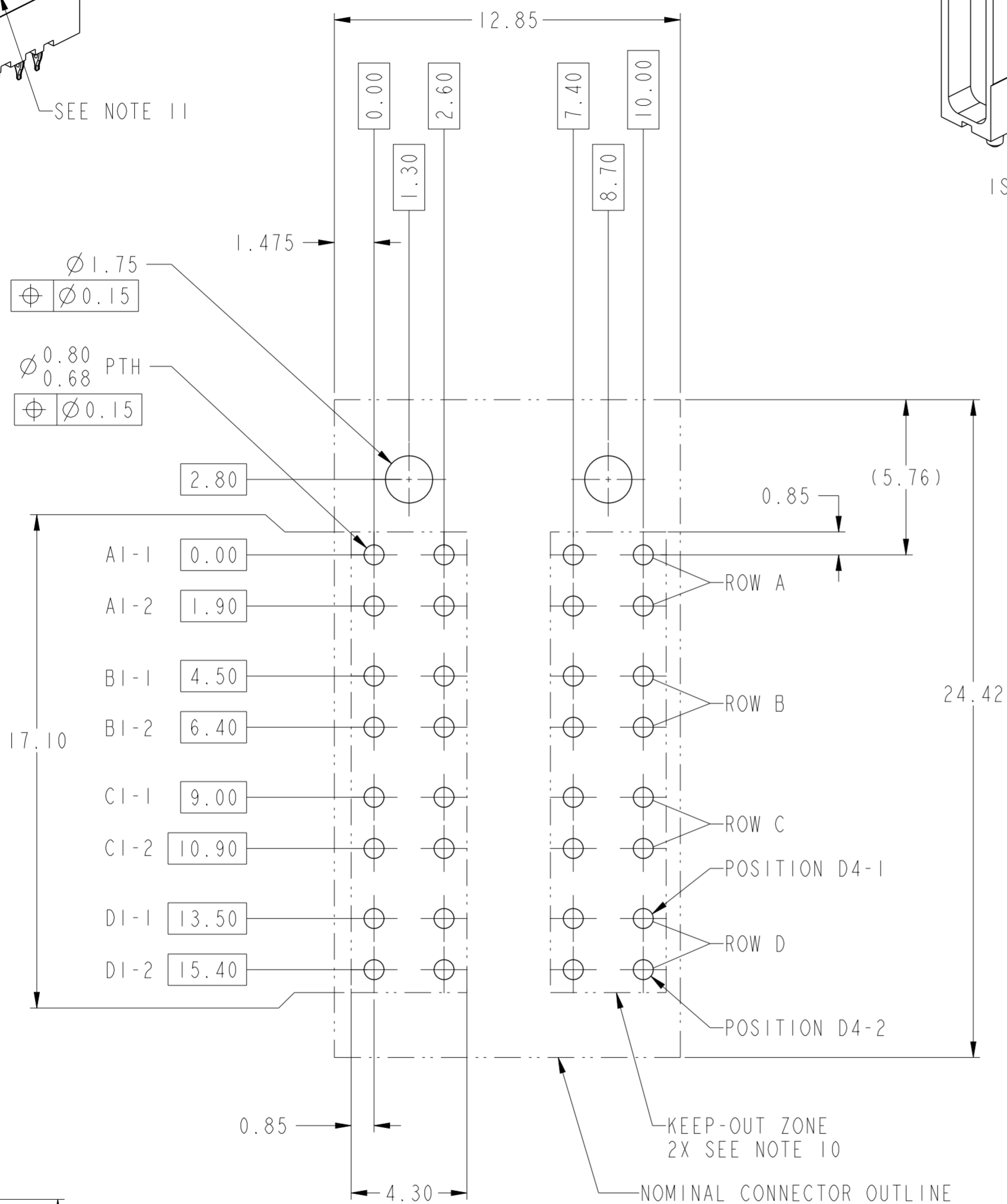

2-SLOT POWER MODULE FOOTPRINT
SCALE 6:1

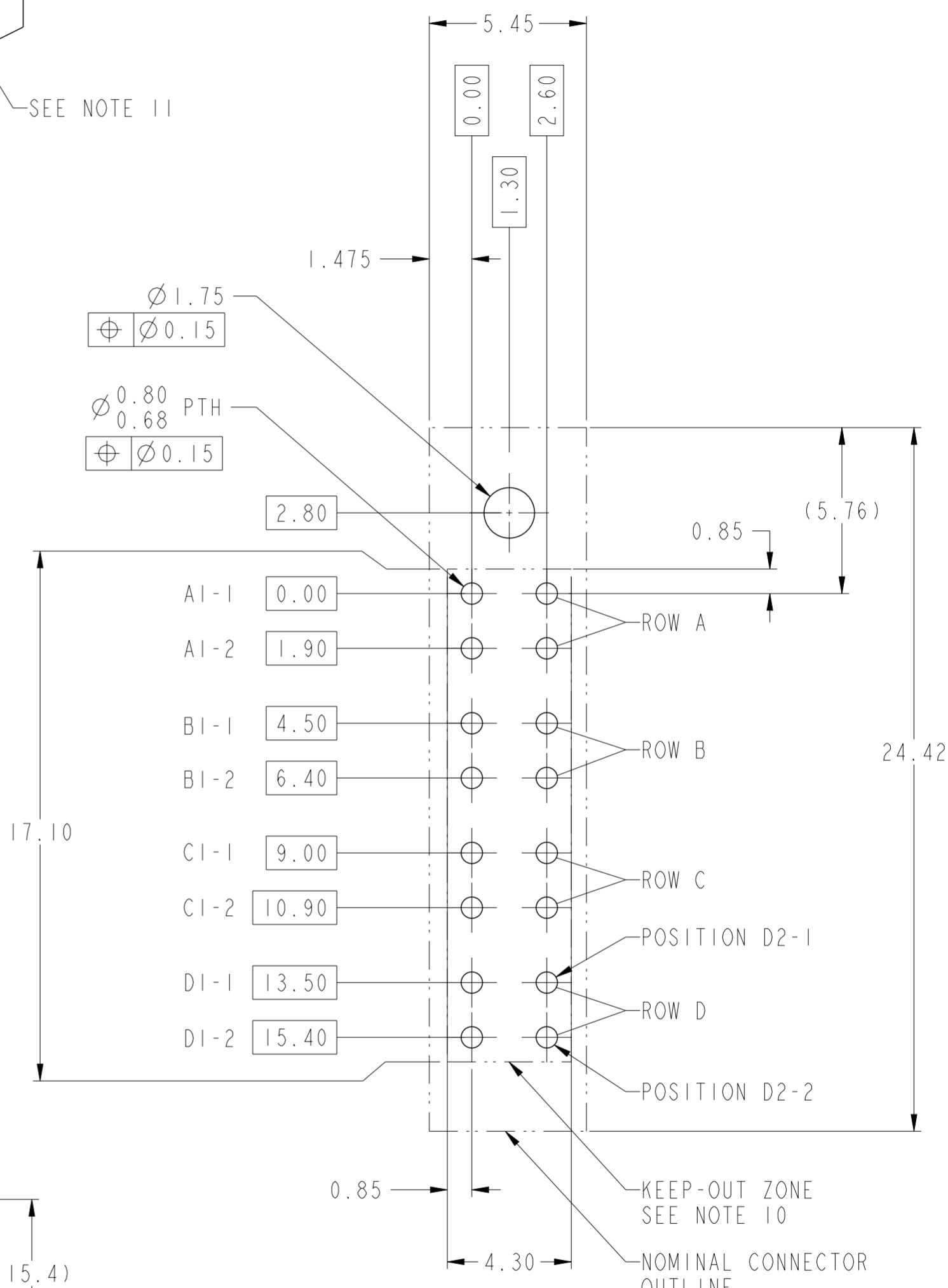

1-SLOT POWER MODULE FOOTPRINT
SCALE 6:1

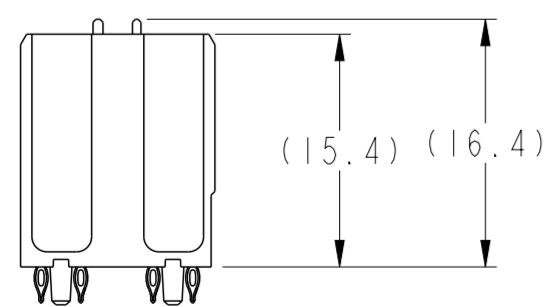

2-SLOT POWER MODULE
BACK VIEW

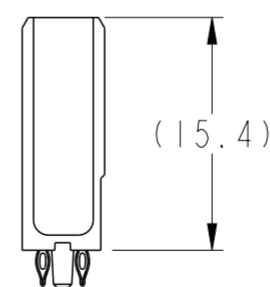

1-SLOT POWER MODULE
BACK VIEW

spec ref	SEE NOTES	dr	Jim Swain	2010/02/02	projection	mm	size	A2	scale	4:1									
tolerance std	TOLERANCES UNLESS OTHERWISE SPECIFIED	eng	Lin-Soe Ngwe	2012/11/19		mm	ecn no	-	rel level	Released									
ASME Y14.5		chr	-	apppr							Chen-Hong Tan	2012/11/19	product family						
surface	<table border="1"> <tr> <td>linear</td> <td>0.X</td> <td>±0.25</td> </tr> <tr> <td></td> <td>0.XX</td> <td>±0.13</td> </tr> <tr> <td></td> <td>0.XXX</td> <td>±-</td> </tr> <tr> <td>angular</td> <td>0°</td> <td>±°</td> </tr> </table>	linear	0.X	±0.25		0.XX	±0.13		0.XXX	±-	angular	0°	±°			MODULE ASSEMBLY, POWER XCede 4-PAIR VERTICAL, LOW PROFILE LESS IMM HEIGHT		title 10091831	rev A
linear	0.X	±0.25																	
	0.XX	±0.13																	
	0.XXX	±-																	
angular	0°	±°																	
ASME Y14.5		www.fci.com		cat. no.	Product - Customer Drw		sheet 4 of 5												

NOTES:

1. CONNECTOR MATERIALS:
HOUSING: HIGH-TEMP THERMOPLASTIC, BLACK, UL94V-0
CONTACTS: HIGH PERFORMANCE COPPER ALLOY
2. CONTACT PLATING:
SEPARABLE INTERFACE:
PERFORMANCE -BASED PLATING, QUALIFIED TO MEET THE REQUIREMENTS OF FCI PRODUCT SPECIFICATION GS-12-0989, INCLUDING TELCORDIA GR-1217-CORE (NOVEMBER 1995) CENTRAL OFFICE TEST SEQUENCE.
PRESS FIT TAILS: TIN OR TIN-LEAD ON TAILS, NICKEL UNDERPLATE
3. EACH POWER CONTACT BLADE HAS TWO COMPLIANT PINS
4. THE MODULES SHOWN ON THIS DRAWING MATE WITH FCI DAUGHTERCARD POWER MODULE P/N 10091828-XXX
5. "2-SLOT" AND "3-SLOT" MODULES WILL ACCEPT DC ENDCAPS BETWEEN DC POWER MODULES WITH NO ADDITIONAL SPACE REQUIREMENTS.
6. WHEN USING ENDCAPS BETWEEN SIGNAL WAFERS AND DC POWER MODULES, ADD 1.85mm BETWEEN MODULES FOR EACH ENDCAP
7. FOR EACH ADDITIONAL POWER MODULE, ADD 5.55mm FOR "1-SLOT" MODULES, 12.95mm FOR "2-SLOT" MODULES, AND 20.35mm FOR "3-SLOT" MODULES.
8. PRODUCT SPECIFICATION: GS-12-0989
9. APPLICATION SPECIFICATION: GS-20-0342
10. NO SURFACE TRACES IN KEEP-OUT ZONE
11. PART MARKING, (PART NUMBER, LOT CODE), ON THIS SURFACE.
12. LEAD-FREE PRODUCT MEETS THE EUROPEAN UNION DIRECTIVES AND OTHER COUNTRY REGULATIONS AS DESCRIBED IN FCI SPECIFICATION GS-22-008.
13. PACKAGING MEETS FCI SPECIFICATION GS-14-920 FOR LEAD FREE LABELLING.
14. A Δ SYMBOL WILL BE NEXT TO ANY DIMENSION, VIEW OR NOTE WHICH HAS BEEN MODIFIED WITH THE CURRENT DRAWING REVISION.

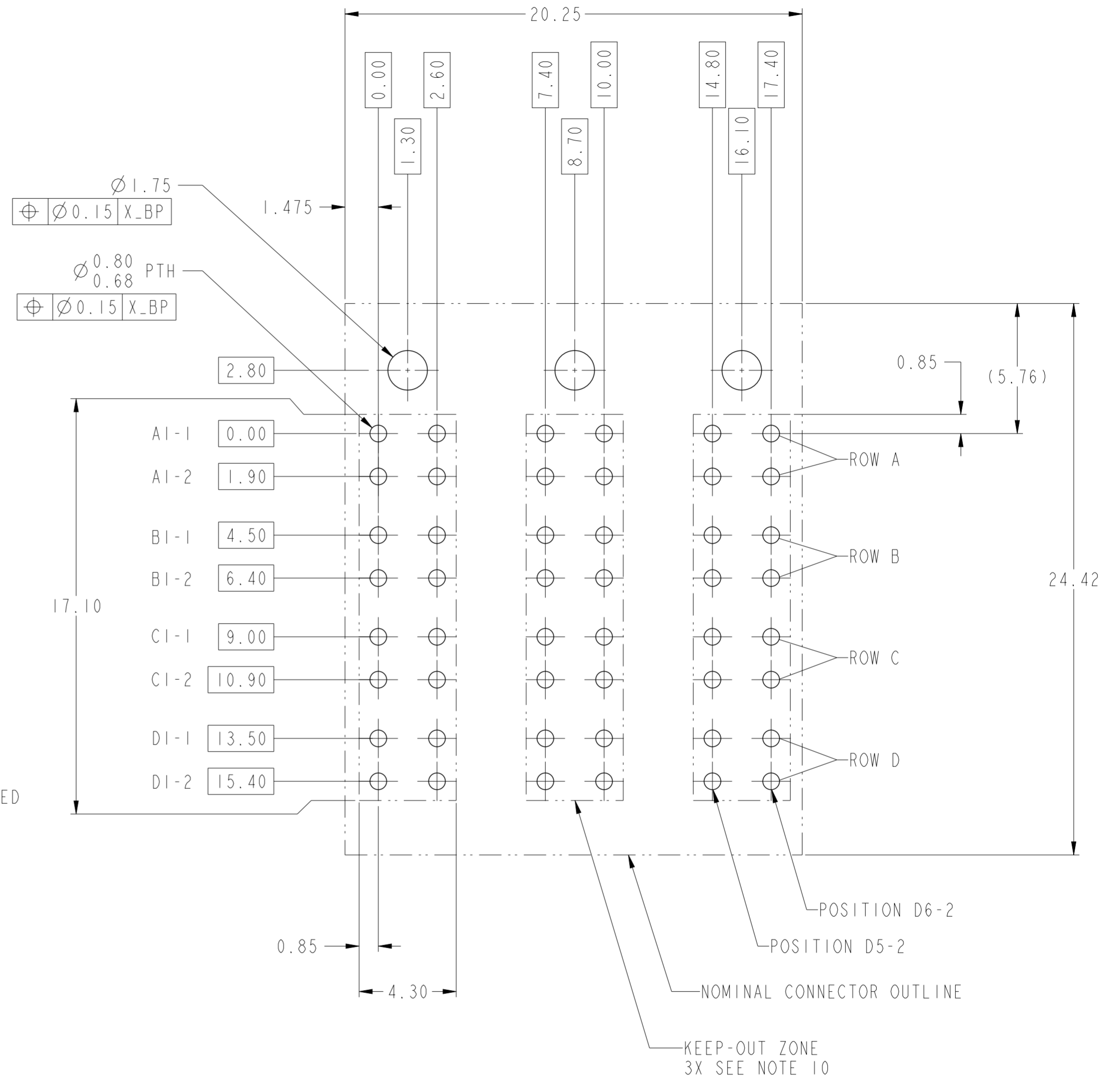

DETAIL A
3-SLOT POWER MODULE FOOTPRINT
SCALE 6:1

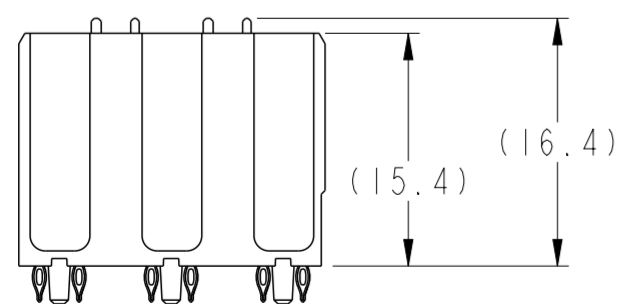

3-SLOT POWER MODULE
BACK VIEW

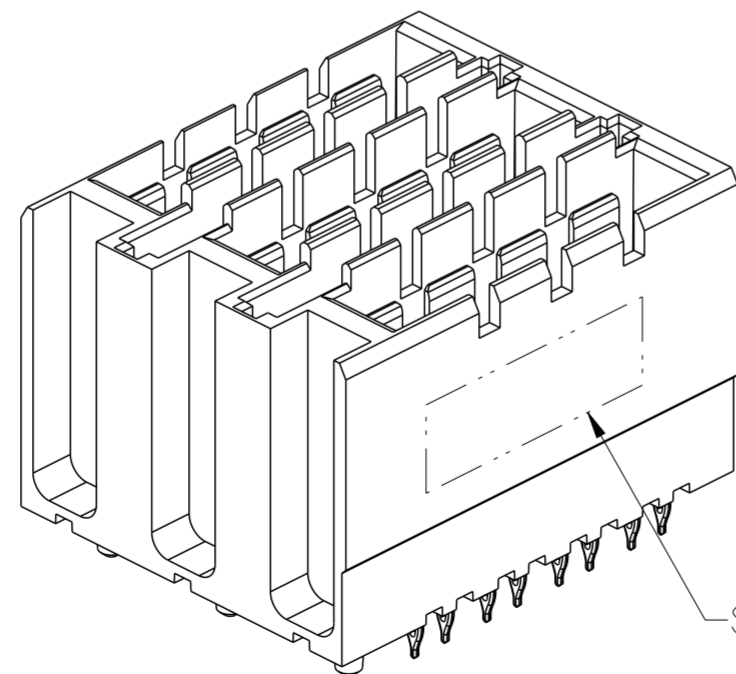

ISOMETRIC VIEW
3 POSITION
SCALE 3:1

spec ref	SEE NOTES	dr	Jim Swain	2010/02/02	projection	mm	size	A2	scale	4:1										
tolerance std	TOLERANCES UNLESS OTHERWISE SPECIFIED	eng	Lin-Soe Ngwe	2012/11/19			ecn no	-	rel level Released	rev A										
ASME Y14.5		chr	-	app			Chen-Hong Tan	2012/11/19			product family									
surface	<table border="1"> <tr> <td>linear</td> <td>0.X</td> <td>±0.25</td> </tr> <tr> <td></td> <td>0.XX</td> <td>±0.13</td> </tr> <tr> <td></td> <td>0.XXX</td> <td>±</td> </tr> <tr> <td>angular</td> <td>0°</td> <td>±°</td> </tr> </table>	linear	0.X	±0.25		0.XX	±0.13		0.XXX	±	angular	0°	±°			title MODULE ASSEMBLY, POWER XCede 4-PAIR VERTICAL, LOW PROFILE LESS IMM HEIGHT		dwg no 10091831	Product - Customer Drw	sheet 5 of 5
linear	0.X	±0.25																		
	0.XX	±0.13																		
	0.XXX	±																		
angular	0°	±°																		
ASME Y14.5		www.fci.com	cat. no.																	