

Features

- Internal Frequency-to-voltage Converter
- Externally Controlled Integrated Amplifier
- Overload Limitation with “Fold Back” Characteristic
- Optimized Soft-start Function
- Tacho Monitoring for Shorted and Open Loop
- Automatic Retriggering Switchable
- Triggering Pulse Typically 155 mA
- Voltage and Current Synchronization
- Internal Supply-voltage Monitoring
- Temperature Reference Source
- Current Requirement ≤ 3 mA

Description

The integrated circuit U211B is designed as a phase-control circuit in bipolar technology with an internal frequency-to-voltage converter. The device includes an internal control amplifier which means it can be used for speed-regulated motor applications.

Amongst others, the device features integrated load limitation, tacho monitoring and soft-start functions, to realize sophisticated motor control systems.

Figure 1. Block Diagram

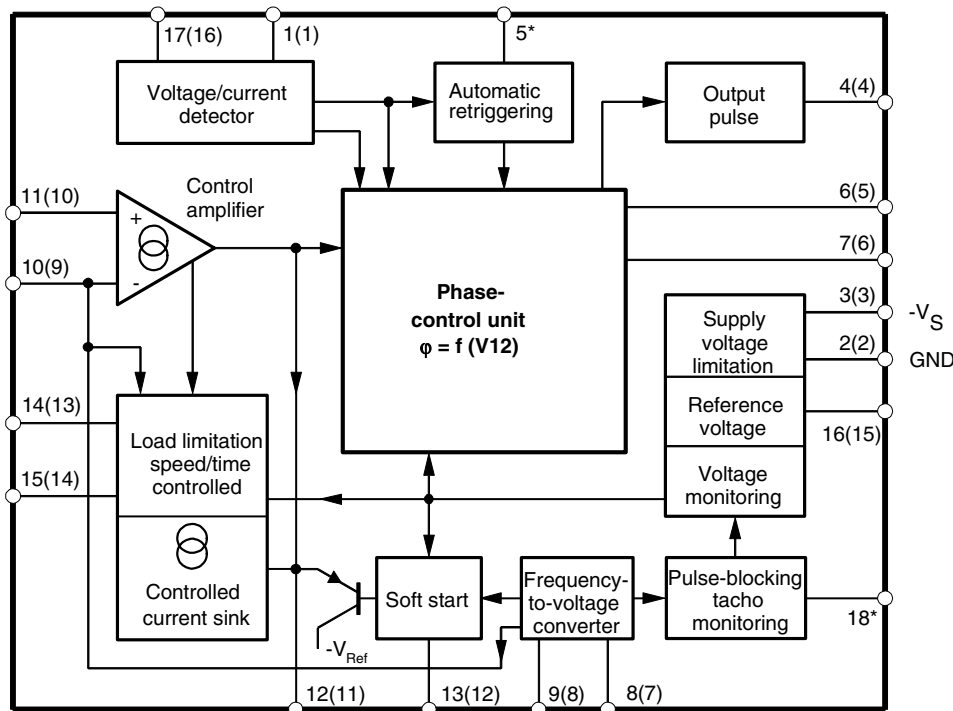

Pin numbers in brackets refer to SO16

* Pins 5 and 18 connected internally



Phase Control IC with Overload Limitation for Tacho Applications

U211B



Pin Configuration

Figure 2. Pinning DIP18

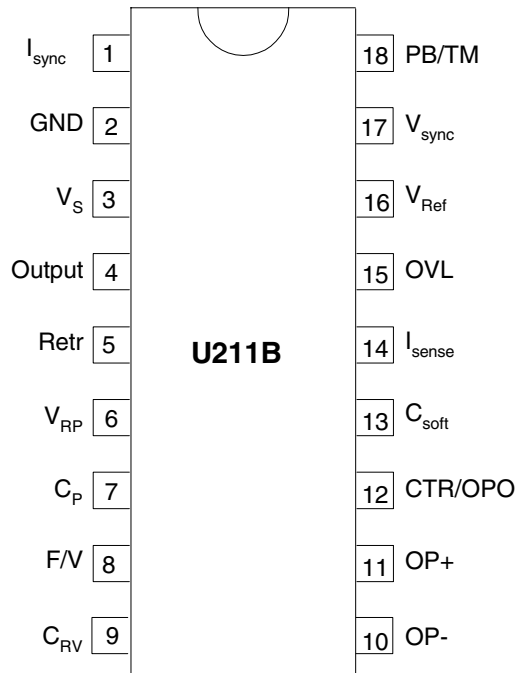

Pin Description

Pin	Symbol	Function
1	I_{sync}	Current synchronization
2	GND	Ground
3	V_S	Supply voltage
4	Output	Trigger pulse output
5	Retr	Retrigger programming
6	V_{RP}	Ramp current adjust
7	C_P	Ramp voltage
8	F/V	Frequency-to-voltage converter
9	C_{RV}	Charge pump
10	OP-	OP inverting input
11	OP+	OP non-inverting input
12	CTR/OPO	Control input/OP output
13	C_{soft}	Soft start
14	I_{sense}	Load-current sensing
15	OVL	Overload adjust
16	V_{Ref}	Reference voltage
17	V_{sync}	Voltage synchronization
18	PB/TM	Pulse blocking/tacho monitoring

Figure 3. Pinning SO16

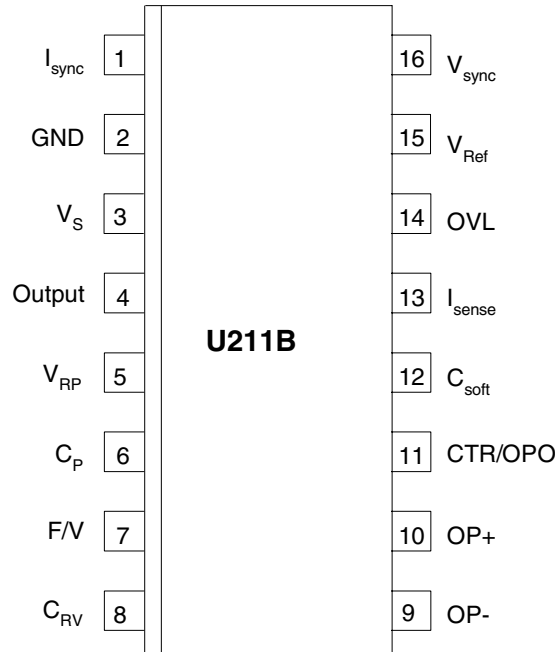

Pin Description

Pin	Symbol	Function
1	I_{sync}	Current synchronization
2	GND	Ground
3	V_S	Supply voltage
4	Output	Trigger pulse output
5	V_{RP}	Ramp current adjust
6	C_P	Ramp voltage
7	F/V	Frequency-to-voltage converter
8	C_{RV}	Charge pump
9	OP-	OP inverting input
10	OP+	OP non-inverting input
11	CTR/OPO	Control input/OP output
12	C_{soft}	Soft start
13	I_{sense}	Load-current sensing
14	OVL	Overload adjust
15	V_{Ref}	Reference voltage
16	V_{sync}	Voltage synchronization

Mains Supply

The U211B is equipped with voltage limiting and can therefore be supplied directly from the mains. The supply voltage between pin 2 (+ pol/_L_) and pin 3 builds up across D_1 and R_1 and is smoothed by C_1 . The value of the series resistance can be approximated using:

$$R_1 = \frac{V_M - V_S}{2 I_S}$$

Further information regarding the design of the mains supply can be found in the section “Design Hints” on page 8. The reference voltage source on pin 16 of typically -8.9 V is derived from the supply voltage and is used for regulation.

Operation using an externally stabilized DC voltage is not recommended.

If the supply cannot be taken directly from the mains because the power dissipation in R_1 would be too large, the circuit as shown in Figure 4 should be used.

Figure 4. Supply Voltage for High Current Requirements

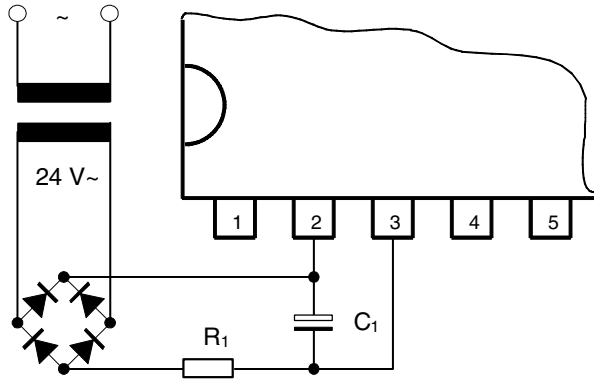

Phase Control

The phase angle of the trigger pulse is derived by comparing the ramp voltage (which is mains synchronized by the voltage detector) with the set value on the control input pin 12. The slope of the ramp is determined by C_2 and its charging current. The charging current can be varied using R_2 on pin 6. The maximum phase angle α_{max} can also be adjusted by using R_2 .

When the potential on pin 7 reaches the nominal value predetermined at pin 12, a trigger pulse is generated whose width t_p is determined by the value of C_2 (the value of C_2 and hence the pulse width can be evaluated by assuming $8 \mu s/nF$). At the same time, a latch is set, so that as long as the automatic retriggering has not been activated, no more pulses can be generated in that half cycle.

The current sensor on pin 1 ensures that, for operations with inductive loads, no pulse will be generated in a new half cycle as long as a current from the previous half cycle is still flowing in the opposite direction to the supply voltage at that instant. This makes sure that “gaps” in the load current are prevented.

The control signal on pin 12 can be in the range of 0 V to -7 V (reference point pin 2).

If $V_{12} = -7 V$, the phase angle is at maximum (α_{max}), i.e., the current flow angle, is at minimum. The phase angle is minimum (α_{min}) when $V_{12} = V_2$.

Voltage Monitoring

As the voltage is built up, uncontrolled output pulses are avoided by internal voltage surveillance. At the same time, all latches in the circuit (phase control, load limit regulation, soft start) are reset and the soft-start capacitor is short circuited. Used with a switching hysteresis of 300 mV, this system guarantees defined start-up behavior each time the supply voltage is switched on or after short interruptions of the mains supply.

Soft Start

As soon as the supply voltage builds up (t_1), the integrated soft start is initiated. Figure 5 shows the behavior of the voltage across the soft-start capacitor, which is identical with the voltage on the phase-control input on pin 12. This behavior guarantees a gentle start-up for the motor and automatically ensures the optimum run-up time.

Figure 5. Soft Start

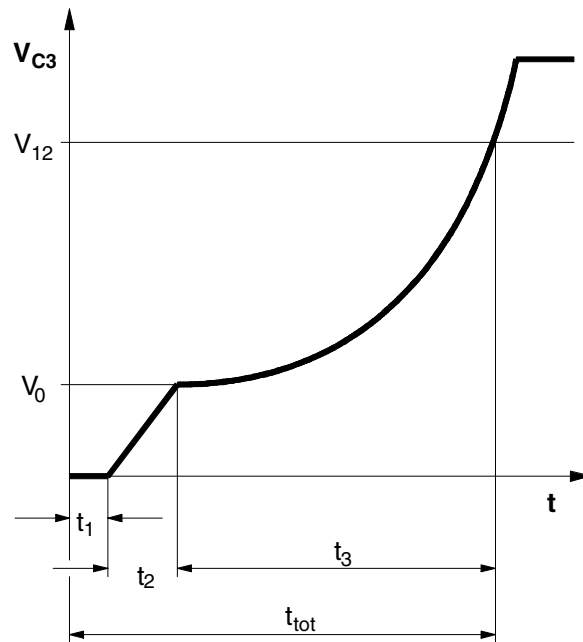

- t_1 = Build-up of supply voltage
- t_2 = Charging of C_3 to starting voltage
- $t_1 + t_2$ = Dead time
- t_3 = Run-up time
- t_{tot} = Total start-up time to required speed

C_3 is first charged up to the starting voltage V_0 with a current of typically $45 \mu\text{A}$ (t_2). By reducing the charging current to approximately $4 \mu\text{A}$, the slope of the charging function is also substantially reduced, so that the rotational speed of the motor only slowly increases. The charging current then increases as the voltage across C_3 increases, resulting in a progressively rising charging function which accelerates the motor more and more with increasing rotational speed. The charging function determines the acceleration up to the set point. The charging current can have a maximum value of $55 \mu\text{A}$.

Frequency-to-voltage Converter

The internal frequency-to-voltage converter (f/V converter) generates a DC signal on pin 10 which is proportional to the rotational speed, using an AC signal from a tachometer or a light beam whose frequency is in turn dependent on the rotational speed. The high-impedance input pin 8 compares the tachometer voltage to a switch-on threshold of typically -100 mV. The switch-off threshold is -50 mV. The hysteresis guarantees very reliable operation even when relatively simple tachometer generators are used.

The tachometer frequency is given by:

$$f = \frac{n}{60} \times p \text{ (Hz)}$$

where: n = Revolutions per minute
p = Number of pulses per revolution

The converter is based on the charge pumping principle. With each negative half-wave of the input signal, a quantity of charge determined by C_5 is internally amplified and then integrated by C_6 at the converter output on pin 10. The conversion constant is determined by C_5 , its charge transfer voltage of V_{ch} , R_6 (pin 10) and the internally adjusted charge transfer gain.

$$G_i \left[\frac{I_{10}}{I_9} \right] = 8.3$$

$$k = G_i \times C_5 \times R_6 \times V_{ch}$$

The analog output voltage is given by

$$V_O = k \times f$$

The values of C_5 and C_6 must be such that for the highest possible input frequency, the maximum output voltage V_O does not exceed 6 V. While C_5 is charging up, the R_i on pin 9 is approximately 6.7 k Ω . To obtain good linearity of the f/V converter, the time constant resulting from R_i and C_5 should be considerably less (1/5) than the time span of the negative half-cycle for the highest possible input frequency. The amount of remaining ripple on the output voltage on pin 10 is dependent on C_5 , C_6 and the internal charge amplification.

$$\Delta V_O = \frac{G_i \times V_{ch} \times C_5}{C_6}$$

The ripple ΔV_O can be reduced by using larger values of C_6 . However, the increasing speed will then also be reduced.

The value of this capacitor should be chosen to fit the particular control loop where it is going to be used.

Pulse Blocking

The output of pulses can be blocked by using pin 18 (standby operation) and the system reset via the voltage monitor if $V_{18} \geq -1.25$ V. After cycling through the switching point hysteresis, the output is released when $V_{18} \leq -1.5$ V, followed by a soft start such as after turn-on.

Monitoring of the rotation can be carried out by connecting an RC network to pin 18. In the event of a short or open circuit, the triac triggering pulses are cut off by the time delay which is determined by R and C. The capacitor C is discharged via an internal resistance $R_i = 2\text{ k}\Omega$ with each charge transfer process of the f/V converter. If there are no more charge transfer processes, C is charged up via R until the switch-off threshold is exceeded and the triac triggering pulses are cut off. For operation without trigger pulse blocking or monitoring of the rotation, pin 18 and pin 16 must be connected together.

Figure 6. Operation Delay

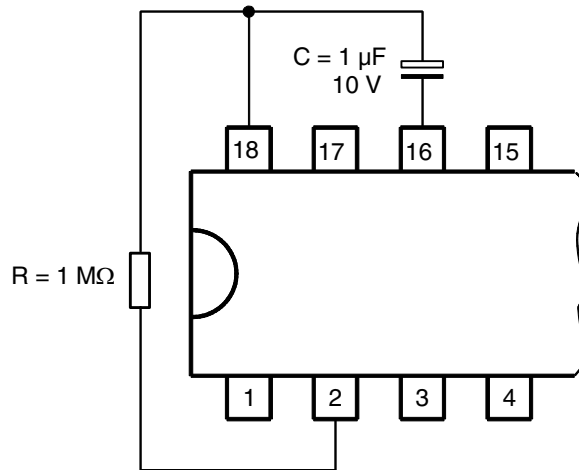

Control Amplifier

The integrated control amplifier (see Figure 24 on page 20) with differential input compares the set value (pin 11) with the instantaneous value on pin 10, and generates a regulating voltage on the output pin 12 (together with the external circuitry on pin 12). This pin always tries to keep the actual voltage at the value of the set voltages. The amplifier has a transmittance of typically $1000\ \mu\text{A/V}$ and a bipolar current source output on pin 12 which operates with typically $\pm 110\ \mu\text{A}$. The amplification and frequency response are determined by R_7 , C_7 , C_8 and R_{11} (can be left out). For open-loop operation, C_4 , C_5 , R_6 , R_7 , C_7 , C_8 and R_{11} can be omitted. Pin 10 should be connected with pin 12 and pin 8 with pin 2. The phase angle of the triggering pulse can be adjusted by using the voltage on pin 11. An internal limitation circuit prevents the voltage on pin 12 from becoming more negative than $V_{16} + 1\text{ V}$.

Load Limitation

The load limitation, with standard circuitry, provides full protection against overloading of the motor. The function of load limiting takes account of the fact that motors operating at higher speeds can safely withstand larger power dissipations than at lower speeds due to the increased action of the cooling fan. Similarly, considerations have been made for short-term overloads for the motor which are, in practice, often required. These behaviors are not damaging and can be tolerated.

In each positive half-cycle, the circuit measures, via R_{10} , the load current on pin 14 as a potential drop across R_8 and produces a current proportional to the voltage on pin 14. This current is available on pin 15 and is integrated by C_9 . If, following high-current amplitudes or a large phase angle for current flow, the voltage on C_9 exceeds an internally set threshold of approximately 7.3 V (reference voltage pin 16), a latch is set and load limiting is turned on. A current source (sink) controlled by the control voltage on pin 15 now draws current from pin 12 and lowers the control voltage on pin 12 so that the phase angle α is increased to α_{max} .

The simultaneous reduction of the phase angle during which current flows causes firstly a reduction of the rotational speed of the motor which can even drop to zero if the angular momentum of the motor is excessively large, and secondly a reduction of the potential on C_9 which in turn reduces the influence of the current sink on pin 12. The control voltage can then increase again and bring down the phase angle. This cycle of action sets up a “balanced condition” between the “current integral” on pin 15 and the control voltage on pin 12.

Apart from the amplitude of the load current and the time during which current flows, the potential on pin 12 and hence the rotational speed also affects the function of load limiting. A current proportional to the potential on pin 10 gives rise to a voltage drop across R_{10} , via pin 14, so that the current measured on pin 14 is smaller than the actual current through R_8 .

This means that higher rotational speeds and higher current amplitudes lead to the same current integral. Therefore, at higher speeds, the power dissipation must be greater than that at lower speeds before the internal threshold voltage on pin 15 is exceeded. The effect of speed on the maximum power is determined by the resistor R_{10} and can therefore be adjusted to suit each individual application.

If, after load limiting has been turned on, the momentum of the load sinks below the “o-momentum” set using R_{10} , V_{15} will be reduced. V_{12} can then increase again so that the phase angle is reduced. A smaller phase angle corresponds to a larger momentum of the motor and hence the motor runs up, as long as this is allowed by the load momentum. For an already rotating machine, the effect of rotation on the measured “current integral” ensures that the power dissipation is able to increase with the rotational speed. The result is a current-controlled acceleration run-up which ends in a small peak of acceleration when the set point is reached. The load limiting latch is simultaneously reset. Then the speed of the motor is under control again and is capable of carrying its full load. The above mentioned peak of acceleration depends upon the ripple of actual speed voltage. A large amount of ripple also leads to a large peak of acceleration.

The measuring resistor R_8 should have a value which ensures that the amplitude of the voltage across it does not exceed 600 mV.

Design Hints

Practical trials are normally needed for the exact determination of the values of the relevant components for load limiting. To make this evaluation easier, the following table shows the effect of the circuitry on the important parameters for load limiting and summarizes the general tendencies.

Table 1. Load Limiting Parameters

Parameters	Component	Component	Component
	R_{10} Increasing	R_9 Increasing	C_9 Increasing
P_{max}	Increases	Decreases	n.e.
P_{min}	Increases	Decreases	n.e.
$P_{max/min}$	Increases	n.e.	n.e.
t_d	n.e.	Increases	Increases
t_r	n.e.	Increases	Increases

P_{max} - Maximum continuous power dissipation

P_{min} - Power dissipation with no rotation

t_d - Operation delay time

t_r - Recovery time

n.e. - No effect

$$P_1 = f_{(n)} \quad n \neq 0$$

$$P_1 = f_{(n)} \quad n = 0$$

Pulse-output Stage

The pulse-output stage is short-circuit protected and can typically deliver currents of 125 mA. For the design of smaller triggering currents, the function $I_{GT} = f(R_{GT})$ can be taken from Figure 19 on page 17.

Automatic Retriggering

The variable automatic retriggering prevents half cycles without current flow, even if the triac has been turned off earlier, e.g., due to a collector which is not exactly centered (brush lifter) or in the event of unsuccessful triggering. If necessary, another triggering pulse is generated after a time lapse which is determined by the repetition rate set by resistance between pin 5 and pin 3 (R_{5-3}). With the maximum repetition rate (pin 5 directly connected to pin 3), the next attempt to trigger comes after a pause of $4.5 t_p$ and this is repeated until either the triac fires or the half cycle finishes. If pin 5 is not connected, only one trigger pulse per half cycle is generated. Since the value of R_{5-3} determines the charging current of C_2 , any repetition rate set using R_{5-3} is only valid for a fixed value of C_2 .

General Hints and Explanation of Terms

To ensure safe and trouble-free operation, the following points should be taken into consideration when circuits are being constructed or in the design of printed circuit boards.

- The connecting lines from C_2 to pin 7 and pin 2 should be as short as possible. The connection to pin 2 should not carry any additional high current such as the load current. When selecting C_2 , a low temperature coefficient is desirable.
- The common (earth) connections of the set-point generator, the tacho generator and the final interference suppression capacitor C_4 of the f/V converter should not carry load current.
- The tacho generator should be mounted without influence by strong stray fields from the motor.
- The connections from R_{10} and C_5 should be as short as possible.

To achieve a high noise immunity, a maximum ramp voltage of 6 V should be used. The typical resistance R_ϕ can be calculated from I_ϕ as follows:

$$R_\phi (\text{k}\Omega) = \frac{T(\text{ms}) \times 1.13(\text{V}) \times 10^3}{C(\text{nF}) \times 6(\text{V})}$$

T = Period duration for mains frequency (10 ms at 50 Hz)

C_ϕ = Ramp capacitor, maximum ramp voltage 6 V and constant voltage drop at

$R_\phi = 1.13 \text{ V}$

A 10% lower value of R_ϕ (under worst case conditions) is recommended.

Figure 7. Explanation of Terms in Phase Relationship

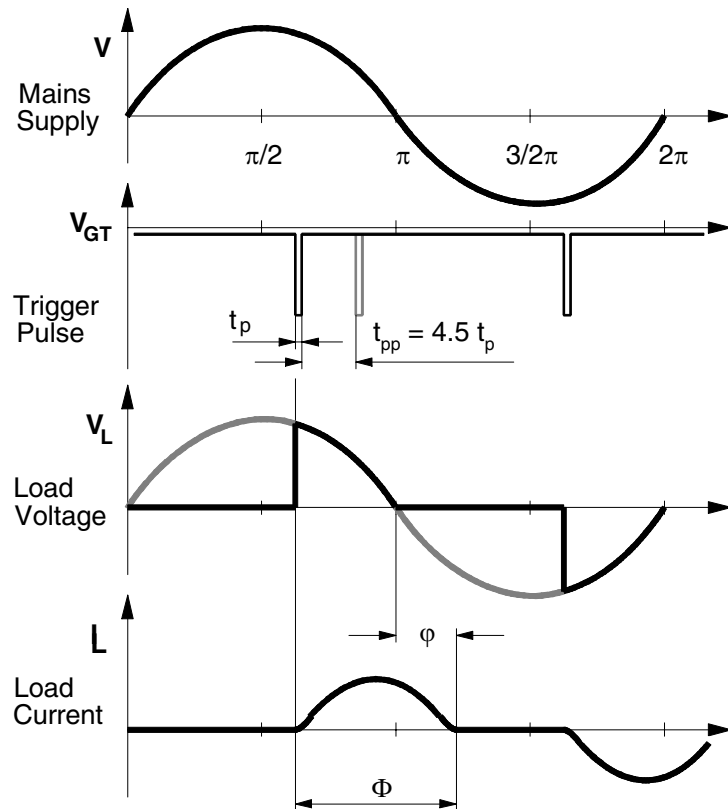

Design Calculations for Main Supply

The following equations can be used for the evaluation of the series resistor R_1 for worst case conditions:

$$R_{1\max} = 0.85 \frac{V_{M\min} - V_{S\max}}{2 I_{\text{tot}}}$$

$$R_{1\min} = \frac{V_M - V_{S\min}}{2 I_{S\max}}$$

$$P_{(R1\max)} = \frac{(V_{M\max} - V_{S\min})^2}{2 R_1}$$

where:

V_M = Mains voltage

V_S = Supply voltage on pin 3

I_{tot} = Total DC current requirement of the circuit
 $= I_S + I_p + I_x$

$I_{S\max}$ = Current requirement of the IC in mA

I_p = Average current requirement of the triggering pulse

I_x = Current requirement of other peripheral components

R_1 can be easily evaluated from the Figure 21 on page 18, Figure 22 on page 18 and Figure 23 on page 19.

Absolute Maximum Ratings

Reference point pin 2, unless otherwise specified

Stresses beyond those listed under “Absolute Maximum Ratings” may cause permanent damage to the device. This is a stress rating only and functional operation of the device at these or any other conditions beyond those indicated in the operational sections of this specification is not implied. Exposure to absolute maximum rating conditions for extended periods may affect device reliability.

Parameters	Pins	Symbol	Value	Unit
Current requirement	3	$-I_S$	30	mA
$t \leq 10 \mu\text{s}$	3	$-i_s$	100	mA
Synchronization current	1	I_{syncI}	5	mA
	17	I_{syncV}	5	mA
$t < 10 \mu\text{s}$	1	$\pm i_i$	35	mA
$t < 10 \mu\text{s}$	17	$\pm i_i$	35	mA
f/V Converter				
Input current	8	I_i	3	mA
$t < 10 \mu\text{s}$	8	$\pm i_i$	13	mA
Load Limiting				
Limiting current, negative half wave	14	I_l	5	mA
$t < 10 \mu\text{s}$	14	I_l	35	mA
Input voltage	14	$\pm V_i$	1	V
	15	$-V_i$	$ V_{16} $ to 0	V
Phase Control				
Input voltage	12	$-V_i$	0 to 7	V
Input current	12	$\pm I_i$	500	μA
	6	$-I_i$	1	mA
Soft Start				
Input voltage	13	$-V_i$	$ V_{16} $ to 0	V
Pulse Output				
Reverse voltage	4	V_R	V_S to 5	V
Pulse Blocking				
Input voltage	18	$-V_i$	$ V_{16} $ to 0	V
Amplifier				
Input voltage	11	V_i	0 to V_S	V
Pin 9 open	10	$-V_i$	$ V_{16} $ to 0	V
Reference Voltage Source				
Output current	16	I_o	7.5	mA
Storage temperature range		T_{stg}	-40 to +125	$^{\circ}\text{C}$
Junction temperature		T_j	125	$^{\circ}\text{C}$
Ambient temperature range		T_{amb}	-10 to +100	$^{\circ}\text{C}$

Thermal Resistance

Parameters		Symbol	Value	Unit
Junction ambient	DIP18	R_{thJA}	120	K/W
	SO16 on p.c.	R_{thJA}	180	K/W
	SO16 on ceramic	R_{thJA}	100	K/W

Electrical Characteristics

$-V_S = 13.0\text{ V}$, $T_{amb} = 25^\circ\text{C}$, reference point pin 2, unless otherwise specified

Parameters	Test Conditions	Pins	Symbol	Min.	Typ.	Max.	Unit
Supply voltage for mains operation		3	$-V_S$	13.0		V_{Limit}	V
Supply voltage limitation	$-I_S = 4\text{ mA}$	3	$-V_S$	14.6		16.6	V
	$-I_S = 30\text{ mA}$			14.7		16.8	V
DC current requirement	$-V_S = 13.0\text{ V}$	3	I_S	1.2	2.5	3.0	mA
Reference voltage source	$-I_L = 10\text{ }\mu\text{A}$	16	$-V_{Ref}$	8.6	8.9	9.2	V
	$-I_L = 5\text{ mA}$			8.3		9.1	V
Temperature coefficient		16	$-TC_{V_{Ref}}$		0.5		mV/K
Voltage Monitoring							
Turn-on threshold		3	$-V_{SON}$	11.2	13.0		V
Turn-off threshold		3	$-V_{SOFF}$	9.9	10.9		V
Phase-control Currents							
Synchronization current		1 17	$\pm I_{syncI}$ $\pm I_{syncV}$	0.35		2.0	mA
Voltage limitation	$\pm I_L = 5\text{ mA}$	1, 17	$\pm V_I$	1.4	1.6	1.8	V
Reference Ramp (see Figure 8 on page 14)							
Charge current	$I_7 = f(R_6)$ $R_6 = 50\text{ k}\Omega$ to $1\text{ M}\Omega$	7	I_7	1	20		μA
R_ϕ -reference voltage	$\alpha \geq 180^\circ$	6, 3	$V_{\phi Ref}$	1.06	1.13	1.18	V
Temperature coefficient		6	$TC_{V_{\phi Ref}}$		0.5		mV/K
Pulse Output (see Figure 19 on page 17, Pin 4)							
Output pulse current	$R_{GT} = 0$, $V_{GT} = 1.2\text{ V}$		I_o	100	155	190	mA
Reverse current			I_{or}		0.01	3.0	μA
Output pulse width	$C_\phi = 10\text{ nF}$		t_p		80		μs
Amplifier							
Common-mode signal range		10, 11	V_{10} , V_{11}	V_{16}		-1	V
Input bias current		11	I_{IO}		0.01	1	μA
Input offset voltage		10, 11	V_{10}		10		mV
Output current		12	$-I_O$ $+I_O$	75	110	145	μA
				88	120	165	μA
Short circuit forward, transmittance	$I_{12} = f(V_{10-11})$, (see Figure 14 on page 16)	12	Y_f		1000		$\mu\text{A/V}$

Electrical Characteristics (Continued)

$-V_S = 13.0\text{ V}$, $T_{\text{amb}} = 25^\circ\text{C}$, reference point pin 2, unless otherwise specified

Parameters	Test Conditions	Pins	Symbol	Min.	Typ.	Max.	Unit
Pulse Blocking, Tacho Monitoring							
Logic-on		18	$-V_{\text{TON}}$	3.7	1.5		V
Logic-off		18	$-V_{\text{TOFF}}$		1.25	1.0	V
Input current	$V_{18} = V_{\text{TOFF}} = 1.25\text{ V}$ $V_{18} = V_{16}$	18	I_I	14.5	0.3	1	μA μA
Output resistance		18	R_O	1.5	6	10	$\text{k}\Omega$
Frequency-to-voltage Converter							
Input bias current		8	I_{IB}		0.6	2	μA
Input voltage limitation	$I_I = -1\text{ mA}$ $I_I = +1\text{ mA}$ (see Figure 14 on page 16)	8	$-V_I$ $+V_I$	660 7.25		750 8.05	mV V
Turn-on threshold		8	$-V_{\text{TON}}$		100	150	mV
Turn-off threshold		8	$-V_{\text{TOFF}}$	20	50		mV
Charge Amplifier							
Discharge current	$C_5 = 1\text{ nF}$, (see Figure 24 on page 20)	9	I_{dis}		0.5		mA
Charge transfer voltage		9 to 16	V_{ch}	6.50	6.70	6.90	V
Charge transfer gain	I_{10}/I_9	9, 10	G_i	7.5	8.3	9.0	
Conversion factor	$C_5 = 1\text{ nF}$, $R_6 = 100\text{ k}\Omega$ (see Figure 24 on page 20)		K		5.5		mV/Hz
Output operating range		10 to 16	V_O		0-6		V
Linearity					± 1		%
Soft Start, f/V Converter Non-active (see Figure 9 on page 14 and Figure 11 on page 15)							
Starting current	$V_{13} = V_{16}$, $V_8 = V_2$	13	I_O	20	45	55	μA
Final current	$V_{13} = 0.5$	13	I_O	50	85	130	μA
f/V Converter Active (see Figure 10 on page 14, Figure 12 on page 15 and Figure 13 on page 15)							
Starting current	$V_{13} = V_{16}$	13	I_O	2	4	7	μA
Final current	$V_{13} = 0.5$		I_O	30	55	80	μA
Discharge current	Restart pulse	13	I_O	0.5	3	10	mA
Automatic Retriggering (see Figure 20 on page 18, Pin 5)							
Repetition rate	$R_{5-3} = 0$		t_{pp}	3	4.5	6	t_p
	$R_{5-3} = 15\text{ k}\Omega$		t_{pp}		20		t_p
Load Limiting (see Figure 16 on page 16, Figure 17 on page 17 and Figure 18 on page 17)							
Operating voltage range		14	V_I	-1.0		+1.0	V
Offset current	$V_{10} = V_{16}$	14	I_O	5		12	μA
	$V_{14} = V_2$ via $1\text{ k}\Omega$	15-16	I_O		0.1	1.0	μA
Input current	$V_{10} = 4.5\text{ V}$	14	I_I	60	90	120	μA
Output current	$V_{14} = 300\text{ mV}$	15-16	I_O	110		140	μA
Overload ON		15-16	V_{TON}	7.05	7.4	7.7	V

Figure 8. Ramp Control

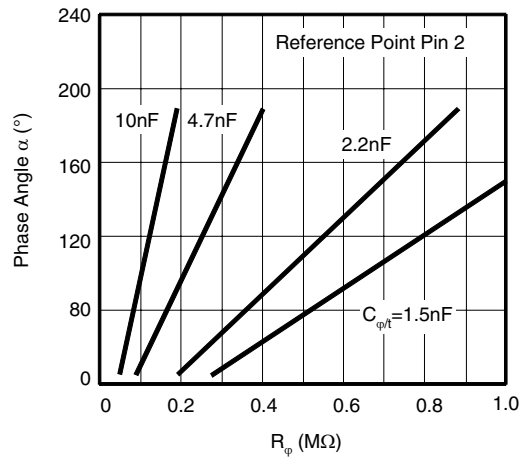

Figure 9. Soft-start Charge Current (f/V Converter Non-active)

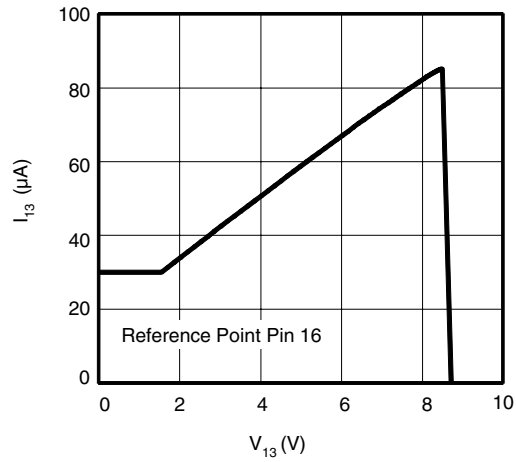

Figure 10. Soft-start Charge Current (f/V Converter Active)

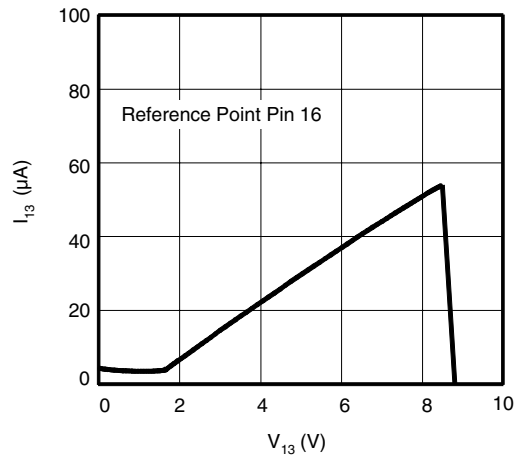

Figure 11. Soft-start Voltage (f/V Converter Non-active)

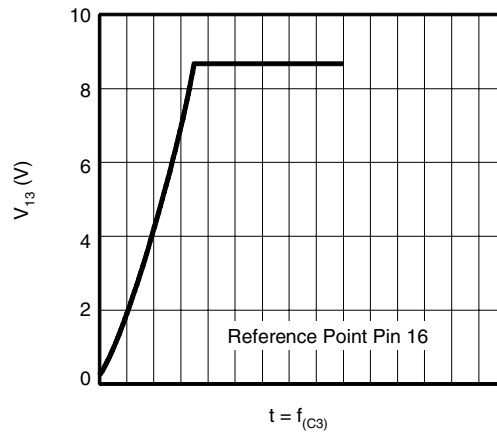

Figure 12. Soft-start Voltage (f/V Converter Active)

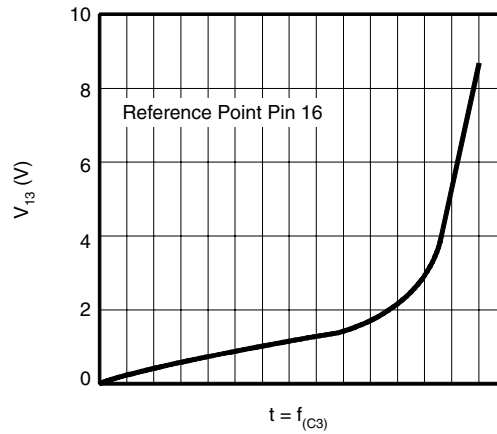

Figure 13. Soft-start Function

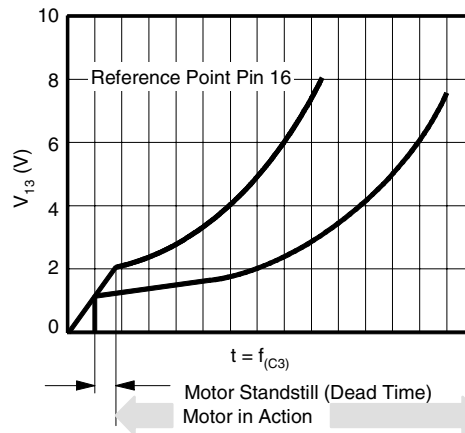

Figure 14. f/V Converter Voltage Limitation

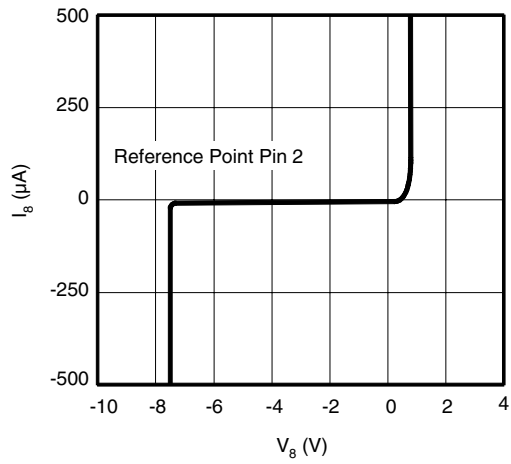

Figure 15. Amplifier Output Characteristics

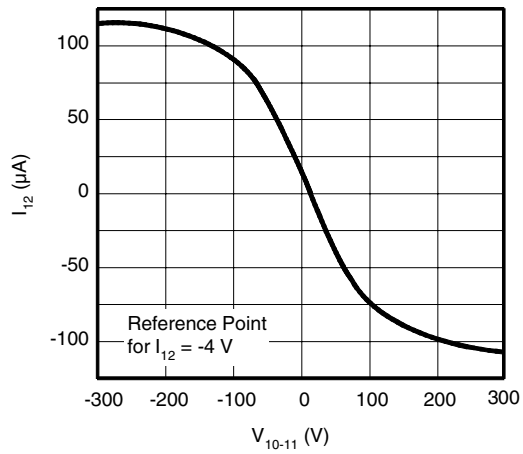

Figure 16. Load Limit Control

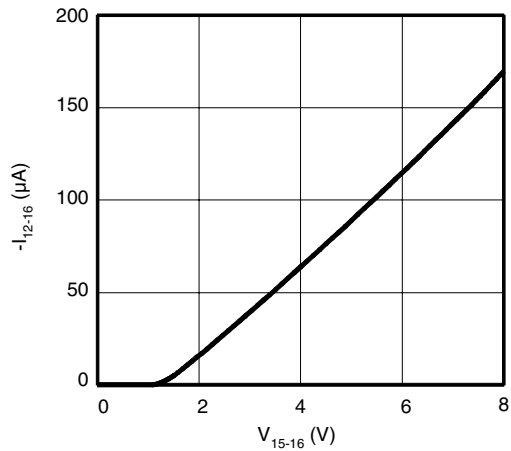

Figure 17. Load Limit Control f/V Dependency

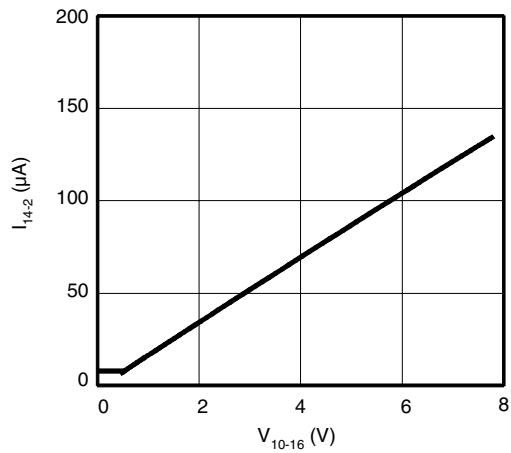

Figure 18. Load Current Detection

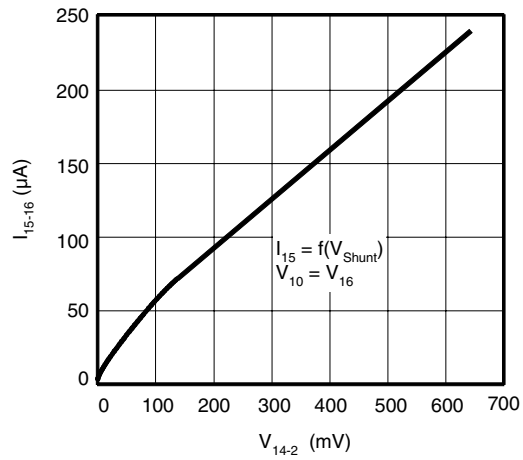

Figure 19. Pulse Output

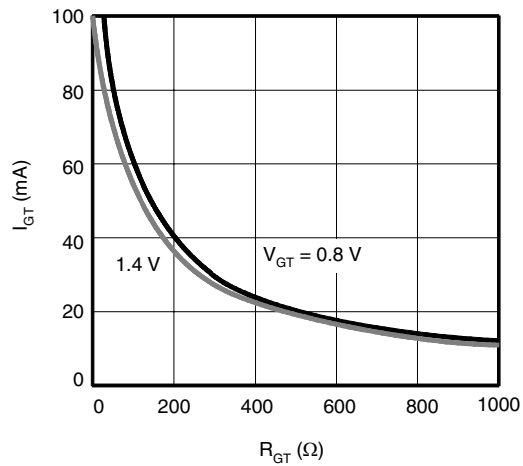

Figure 20. Automatic Retriggering Repetition Rate

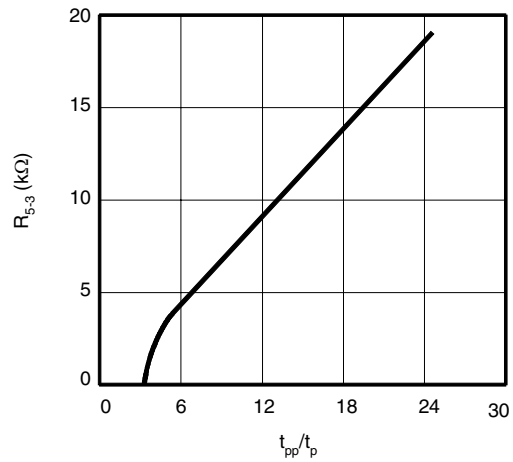

Figure 21. Determination of R_1

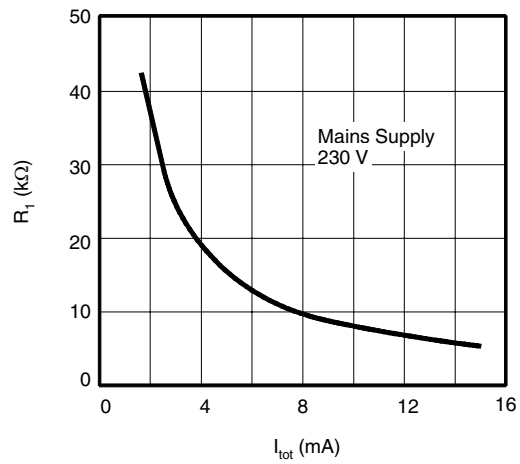

Figure 22. Power Dissipation of R_1

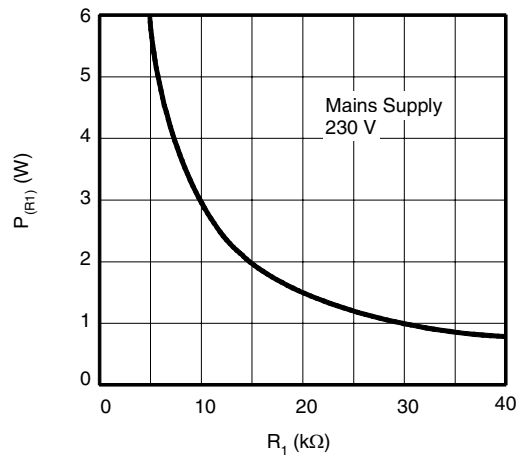

Figure 23. Power Dissipation of R_1 According to Current Consumption

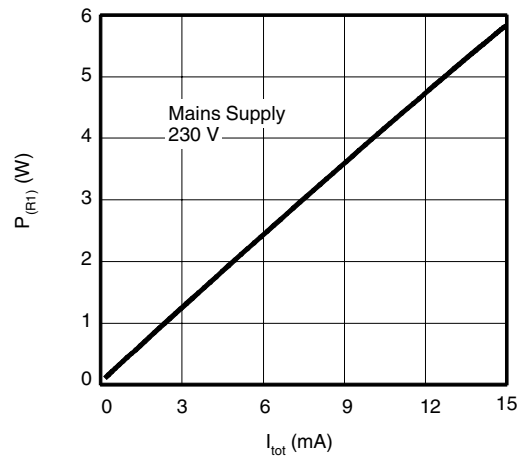

Figure 24. Speed Control, Automatic Retriggering, Load Limiting, Soft Start

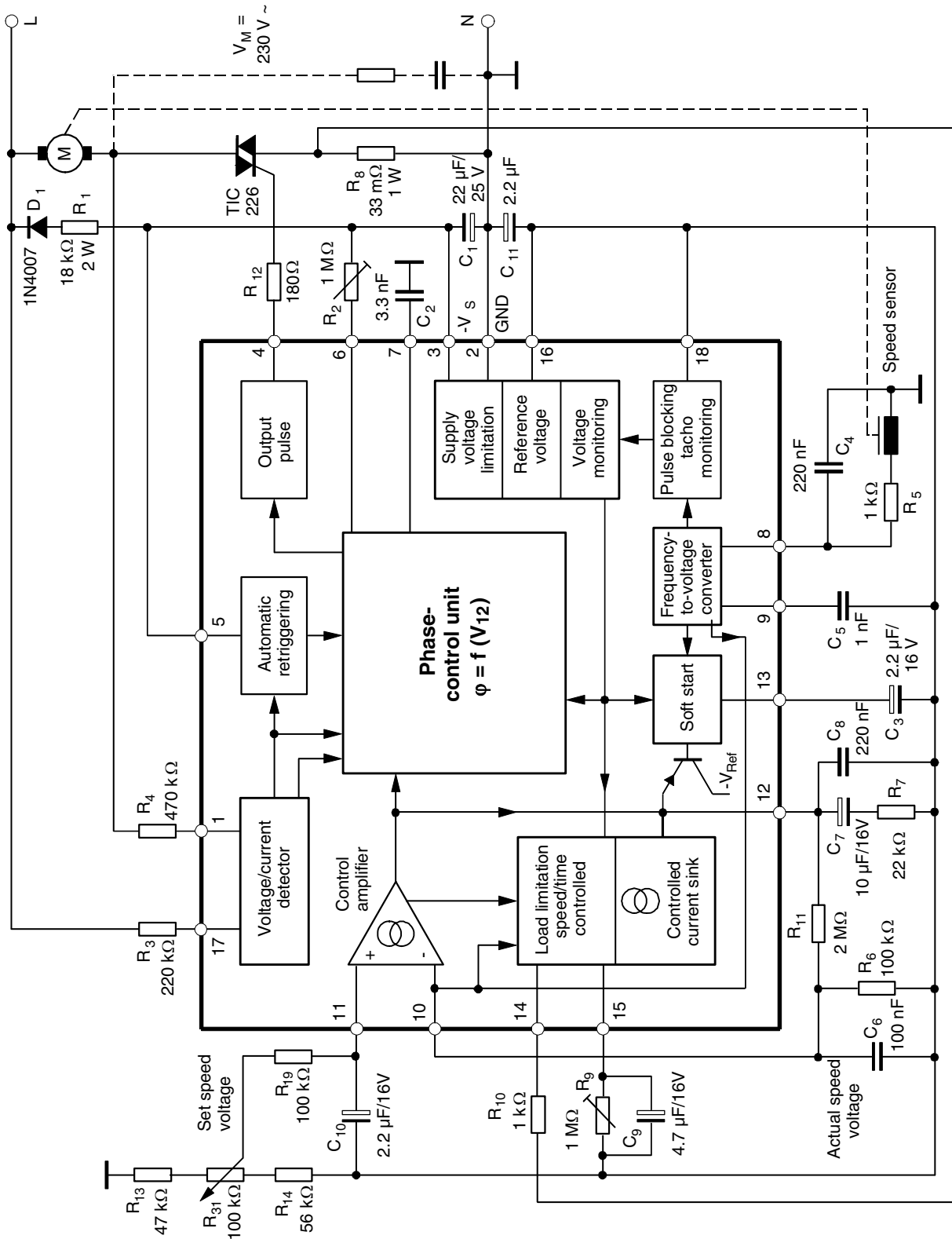
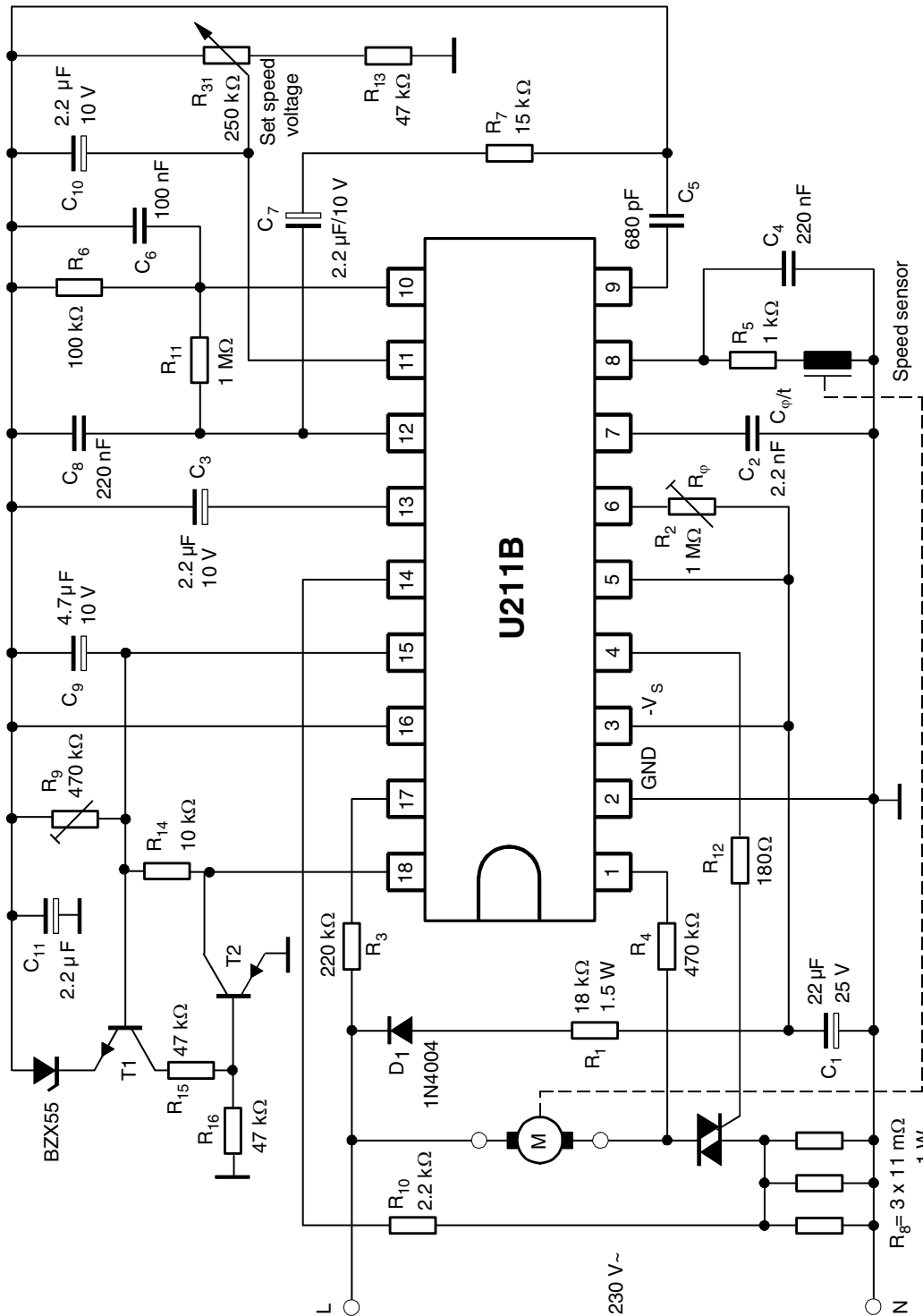

Figure 25. Speed Control, Automatic Retriggering, Load Switch-off, Soft Start



The switch-off level at maximum load shows in principle the same speed dependency as the original version (see Figure 24 on page 20), but when reaching the maximum load, the motor is switched off completely. This function is effected by the thyristor (formed by T₁ and T₂) which ignites when the voltage at pin 15 reaches typically 7.4 V (reference point pin 16). The circuit is thereby switched to standby mode over the release Pin 18.

Figure 27. Speed Control, Automatic Retriggering, Load Limiting, Soft Start, Tacho Control

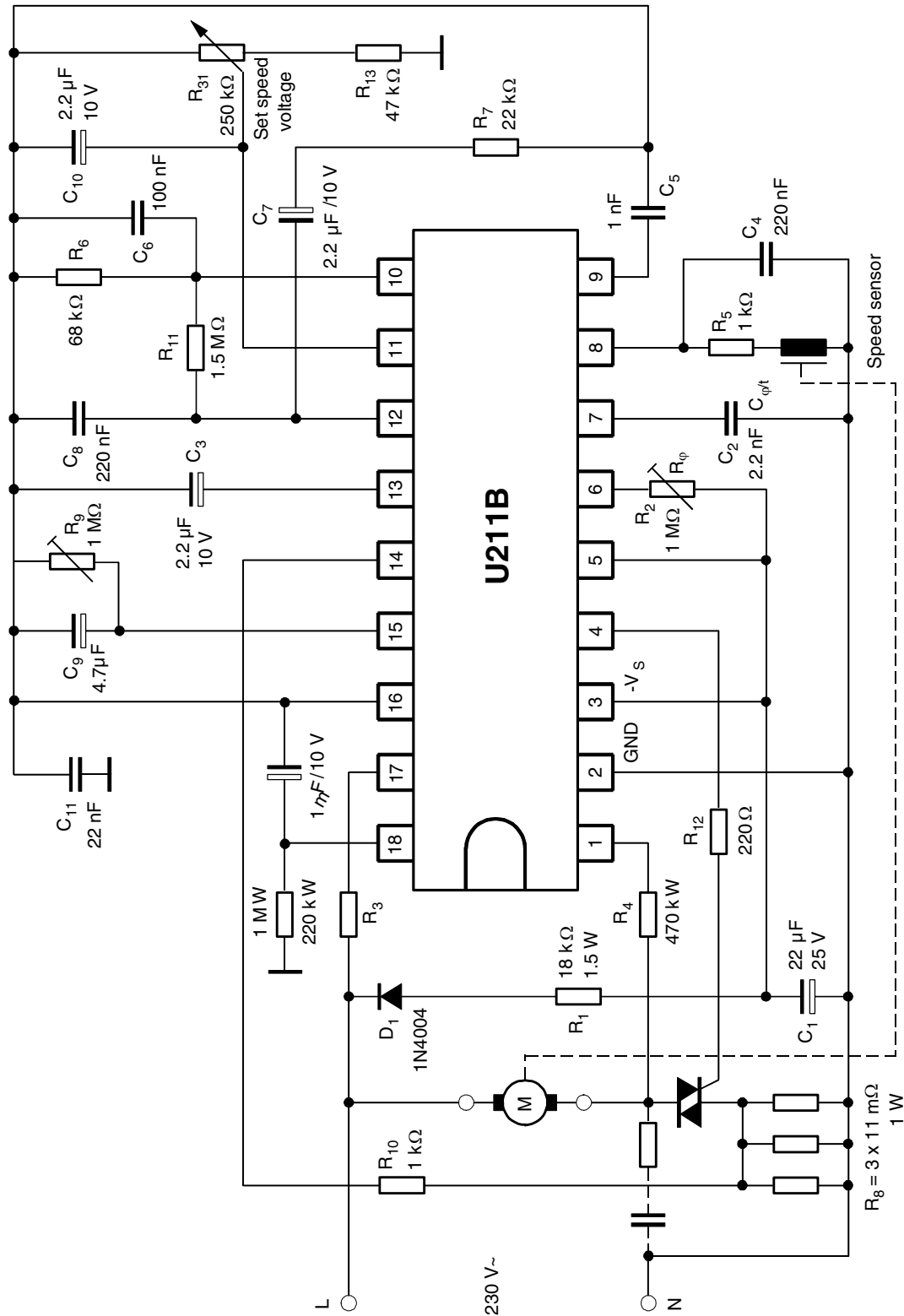
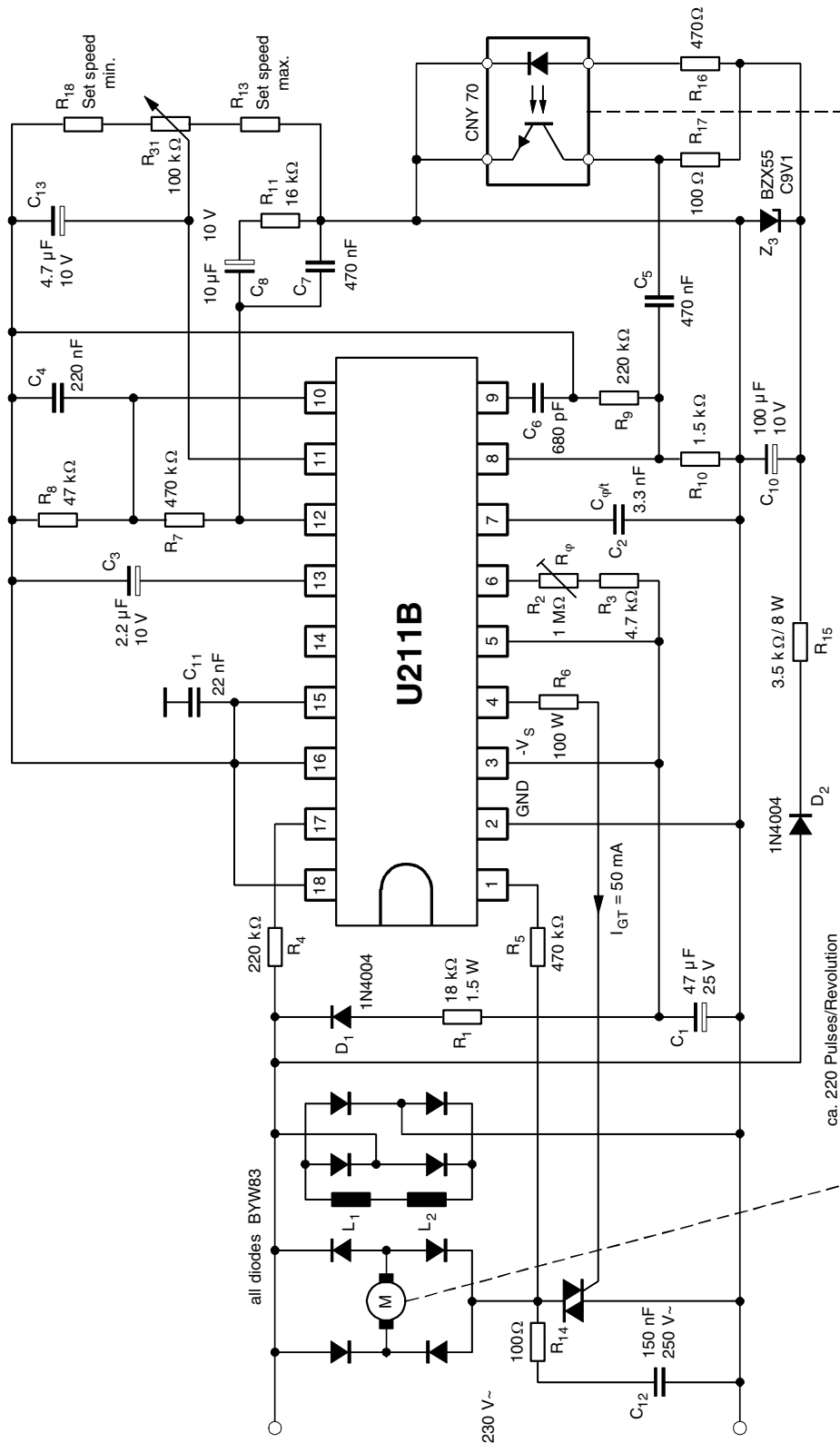

Figure 28. Speed Control with Reflective Opto Coupler CNY70 as Emitter



The schematic diagram (see Figure 29 on page 25) is designed as a speed control IC based on the reflection-coupled principle with 4 periods per revolution and a maximum speed of 30000 rpm. The separation of the coupler from the rotating aperture should be about approximately 1 mm. In the schematic diagram, the power supply for the coupler was provided externally because of the relatively high current consumption.

Instructions for adjusting:

1. In the initial adjustment of the phase-control circuit, R_2 should be adjusted so that when $R_{14} = 0$ and R_{31} are in minimum position, the motor just turns.
2. The speed can now be adjusted as desired by means of R_{31} between the limits determined by R_{13} and R_{14} .
3. The switch-off power of the limiting-load control can be set by R_9 . The lower R_9 , the higher the switch-off power.

Ordering Information

Extended Type Number	Package	Remarks
U211B-x	DIP18	Tube
U211B-xFP	SO16	Tube
U211B-xFPG3	SO16	Taped and reeled

Package Information

Package DIP18

Dimensions in mm

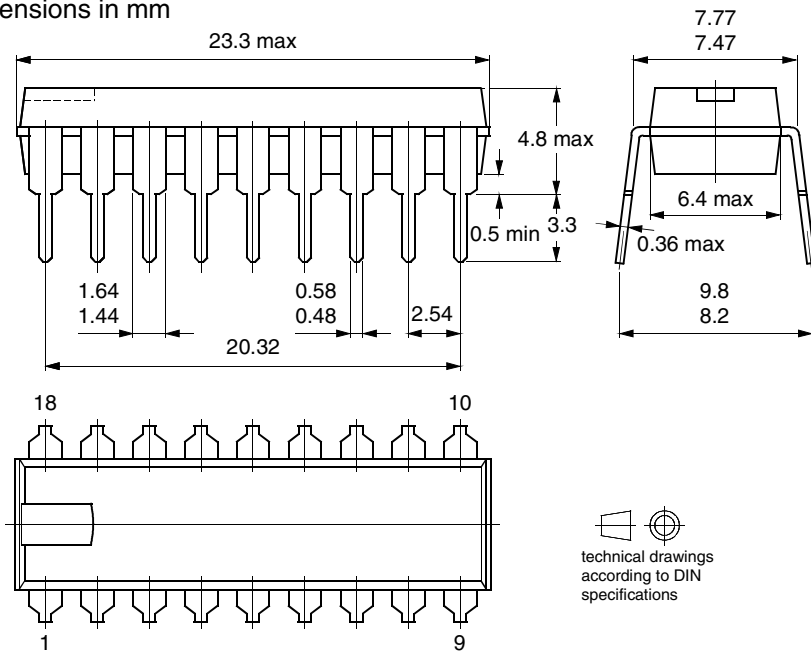

Package SO16

Dimensions in mm

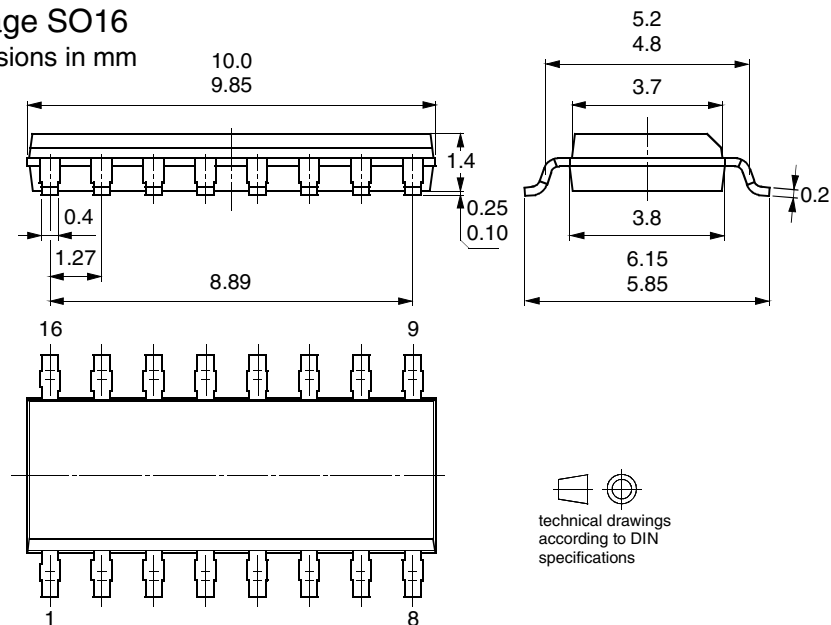



Atmel Corporation

2325 Orchard Parkway
San Jose, CA 95131, USA
Tel: 1(408) 441-0311
Fax: 1(408) 487-2600

Regional Headquarters

Europe

Atmel Sarl
Route des Arsenalux 41
Case Postale 80
CH-1705 Fribourg
Switzerland
Tel: (41) 26-426-5555
Fax: (41) 26-426-5500

Asia

Room 1219
Chinachem Golden Plaza
77 Mody Road Tsimshatsui
East Kowloon
Hong Kong
Tel: (852) 2721-9778
Fax: (852) 2722-1369

Japan

9F, Tonetsu Shinkawa Bldg.
1-24-8 Shinkawa
Chuo-ku, Tokyo 104-0033
Japan
Tel: (81) 3-3523-3551
Fax: (81) 3-3523-7581

Atmel Operations

Memory

2325 Orchard Parkway
San Jose, CA 95131, USA
Tel: 1(408) 441-0311
Fax: 1(408) 436-4314

Microcontrollers

2325 Orchard Parkway
San Jose, CA 95131, USA
Tel: 1(408) 441-0311
Fax: 1(408) 436-4314

La Chantrerie
BP 70602
44306 Nantes Cedex 3, France
Tel: (33) 2-40-18-18-18
Fax: (33) 2-40-18-19-60

ASIC/ASSP/Smart Cards

Zone Industrielle
13106 Rousset Cedex, France
Tel: (33) 4-42-53-60-00
Fax: (33) 4-42-53-60-01

1150 East Cheyenne Mtn. Blvd.
Colorado Springs, CO 80906, USA
Tel: 1(719) 576-3300
Fax: 1(719) 540-1759

Scottish Enterprise Technology Park
Maxwell Building
East Kilbride G75 0QR, Scotland
Tel: (44) 1355-803-000
Fax: (44) 1355-242-743

RF/Automotive

Theresienstrasse 2
Postfach 3535
74025 Heilbronn, Germany
Tel: (49) 71-31-67-0
Fax: (49) 71-31-67-2340

1150 East Cheyenne Mtn. Blvd.
Colorado Springs, CO 80906, USA
Tel: 1(719) 576-3300
Fax: 1(719) 540-1759

Biometrics/Imaging/Hi-Rel MPU/ High Speed Converters/RF Datacom

Avenue de Rochepleine
BP 123
38521 Saint-Egreve Cedex, France
Tel: (33) 4-76-58-30-00
Fax: (33) 4-76-58-34-80

Literature Requests

www.atmel.com/literature

Disclaimer: Atmel Corporation makes no warranty for the use of its products, other than those expressly contained in the Company's standard warranty which is detailed in Atmel's Terms and Conditions located on the Company's web site. The Company assumes no responsibility for any errors which may appear in this document, reserves the right to change devices or specifications detailed herein at any time without notice, and does not make any commitment to update the information contained herein. No licenses to patents or other intellectual property of Atmel are granted by the Company in connection with the sale of Atmel products, expressly or by implication. Atmel's products are not authorized for use as critical components in life support devices or systems.

© Atmel Corporation 2003. All rights reserved.

Atmel® and combinations thereof are the registered trademarks of Atmel Corporation or its subsidiaries.

Other terms and product names may be the trademarks of others.



Printed on recycled paper.