

LOC		DIST		REVISIONS			
P	LTR	DESCRIPTION	DATE	DN	APVD		
D		REV PER ECO 08-030664	4-15-09	PY	RL		

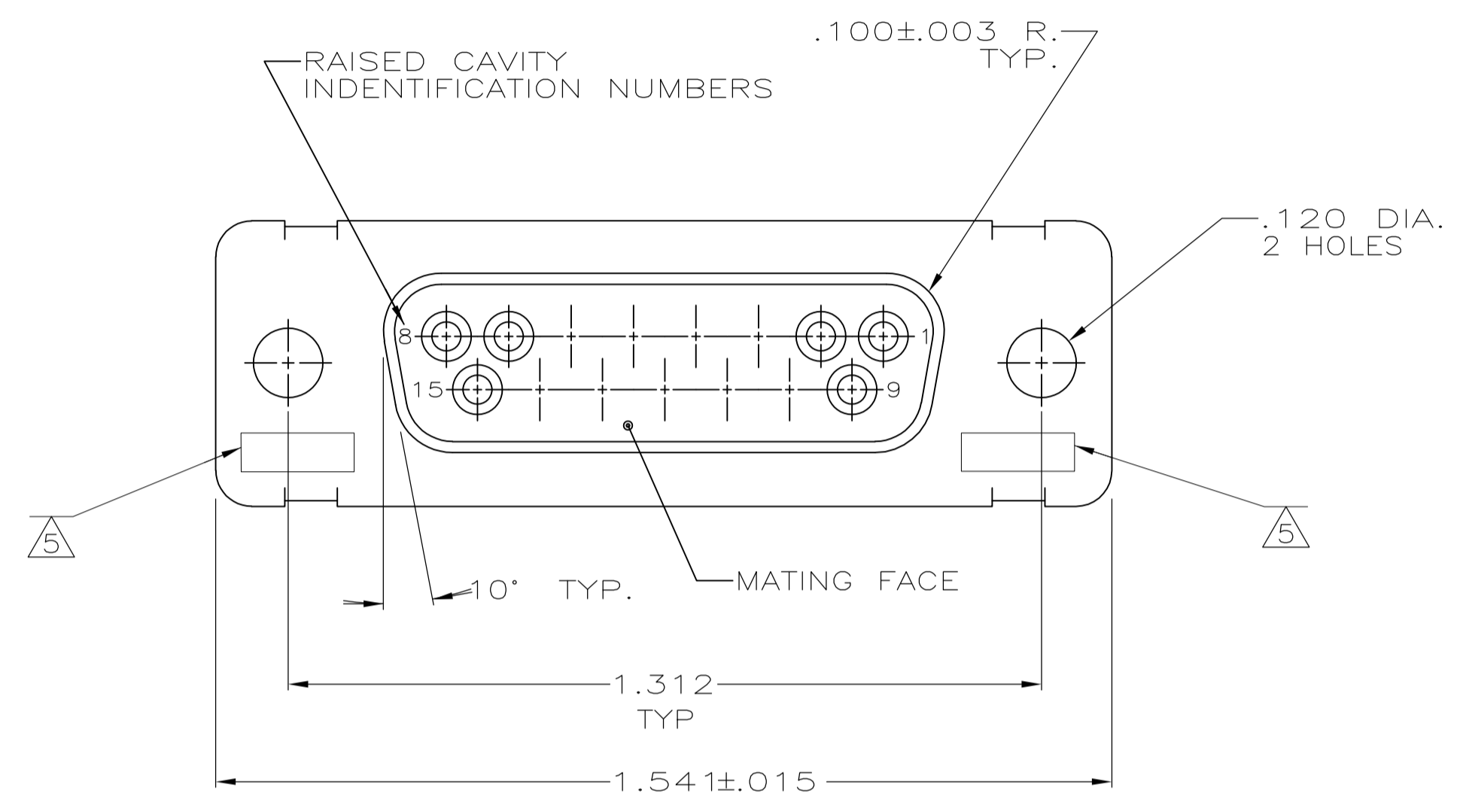

1. THIS RECEPTACLE WILL MATE WITH ANY 15 POSN., SIZE 2 PLUG IN THE AMPLIMITE SERIES.
 2. MAXIMUM WIRE INSULATION USED WITH THIS CONNECTOR IS .068 DIA.
 3. BE-CU RETENTION CLIPS ARE INCLUDED IN INSERT.
 4. CONNECTOR SUPPLIED WITHOUT CONTACTS; SHOWN FOR ILLUSTRATION ONLY.
- ⚠ UL/CSA DESIGNATION STAMPED IN THIS AREA.

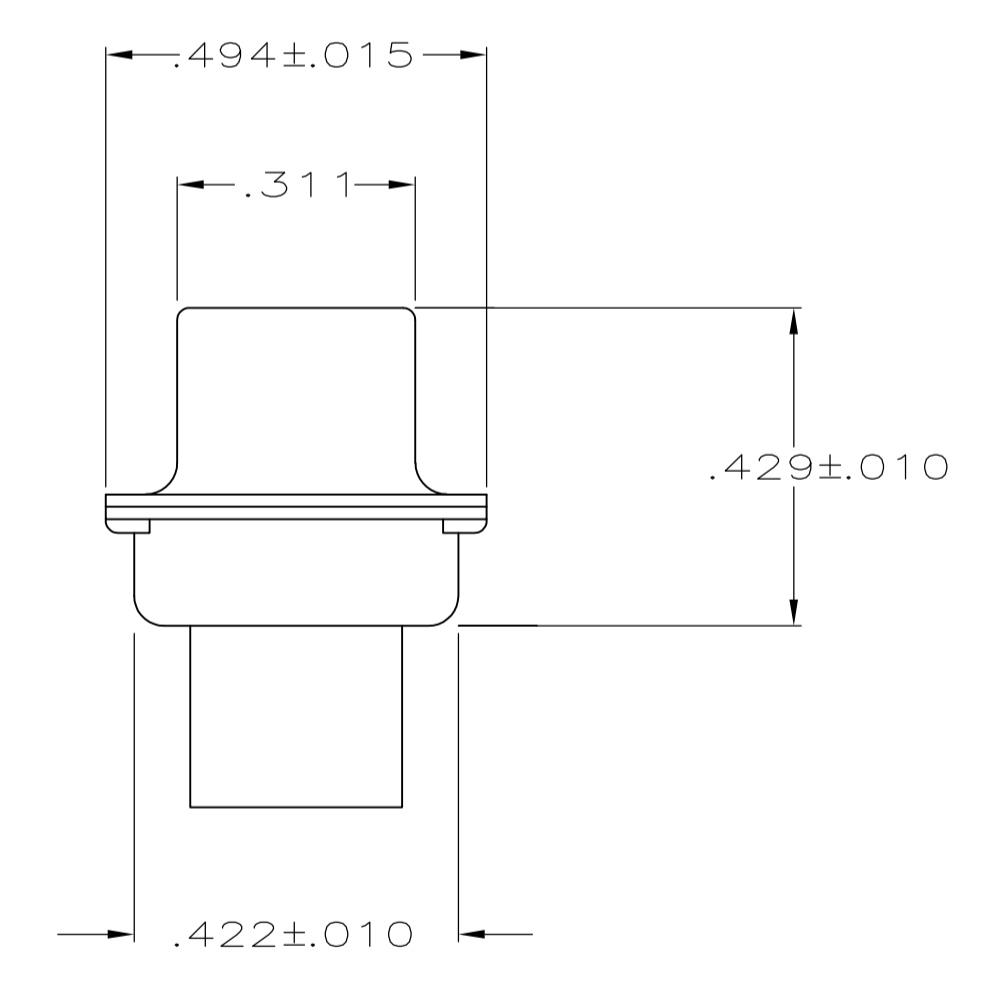
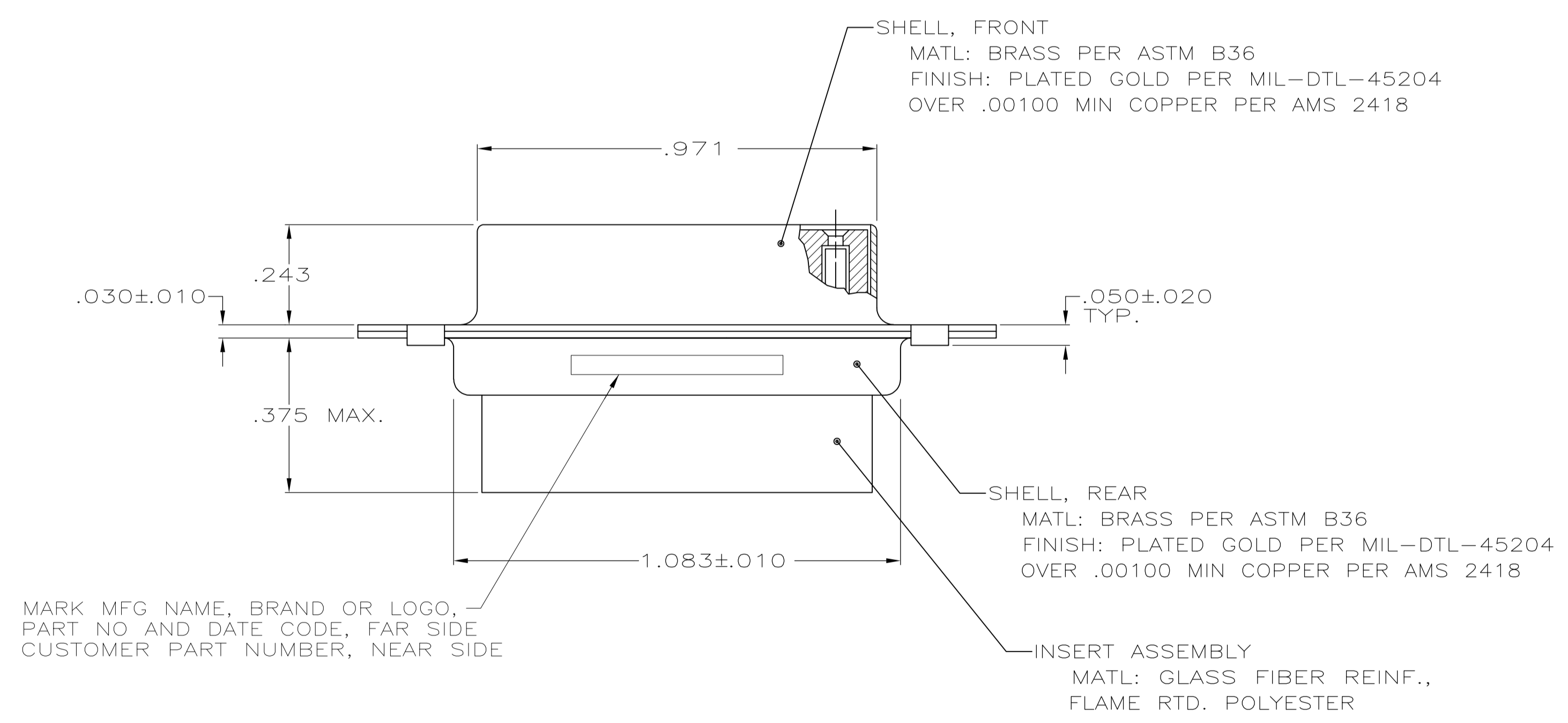

MARK MFG NAME, BRAND OR LOGO, PART NO AND DATE CODE, FAR SIDE
 CUSTOMER PART NUMBER, NEAR SIDE

1A01-002RHW	1-211614-1
1A01-002RHA	211614-1
CUSTOMER PART NO	PART NO

THIS DRAWING IS A CONTROLLED DOCUMENT.		DIN T. SHUEY 11-12-87		Tyco Electronics Corporation	
DIMENSIONS: INCHES		CHK F.C. BALLEW III 11-30-87		Harrisburg, PA 17105-3608	
TOLERANCES UNLESS OTHERWISE SPECIFIED:		APVD		NAME	
0 PLC ± -		PRODUCT SPEC		RECEPTACLE ASSY, AMPLIMITE	
1 PLC ± -		APPLICATION SPEC		15 POSN, SIZE 2, SERIES 109	
2 PLC ± -		SIZE		NON-MAGNETIC	
3 PLC ± .005		CAGE CODE		DRAWING NO	
4 PLC ± -		WEIGHT		RESTRICTED TO	
ANGLES ± -		A1 00779		C=211614	
FINISH SEE CALLOUTS		CUSTOMER DRAWING		SCALE 4:1 SHEET 1 OF 1 REV D	