

## High Brightness LED Current Regulator

### FEATURES AND BENEFITS

- AEC-Q100 qualified
- LED drive current up to 350 mA
- 6 to 40 V supply
- Reverse battery protection
- Low drop-out voltage
- LED short circuit and thermal protection
- 10  $\mu$ A maximum shutdown current
- PWM dimming control input
- Current slew rate limiting

### PACKAGE: 8-pin SOICN with exposed thermal pad (suffix LJ)

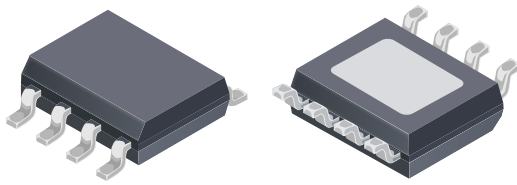

Not to scale

Not to scale

### DESCRIPTION

The A6260 is a linear programmable current regulator providing up to 350 mA for driving high-brightness LEDs. The LED current, accurate to 4%, is set by a single low-power sense resistor. Driving LEDs with constant current ensures safe operation with maximum possible light output. For automotive applications, optimum performance is achieved when driving between 1 and 3 LEDs at currents up to 350 mA.

The low drop-out voltage of the A6260 allows a single white LED to be driven safely, at full current, with a supply voltage down to 6 V.

An enable input allows PWM dimming and can be used to enable low-current sleep mode. The rate of change of current during PWM switching is limited to reduce EMI.

Overcurrent detection is provided to protect the LEDs and the A6260 during short-to-supply or short-to-ground at any LED terminal.

The integrated temperature monitor can be used to reduce the LED drive current if the chip temperature exceeds the thermal limit.

The device is available in an 8-pin SOIC package with exposed thermal pad (suffix LJ). The device is lead (Pb) free with 100% matte-tin leadframe plating.

### Typical Application

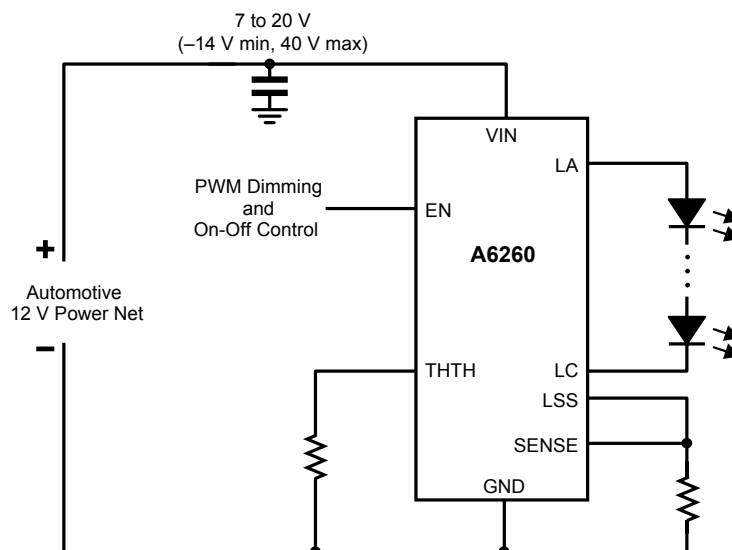

## SELECTION GUIDE

Part Number	Packing	Ambient Temperature, $T_A$ (°C)
A6260KLJTR-T	3000 pieces per reel	-40 to 125
A6260SLJTR-T	3000 pieces per reel	-20 to 85

## ABSOLUTE MAXIMUM RATINGS\*

Characteristic	Symbol	Notes	Rating	Units
Load Supply Voltage	$V_{IN}$		-14 to 40	V
EN Pin Voltage	$V_{EN}$		-14 to 40	V
LA and LC Pins Voltage	$V_{Lx}$		-0.3 to 40	V
LSS Pin Voltage	$V_{LSS}$		-0.3 to 0.3	V
SENSE Pin Voltage	$V_{SENSE}$		-0.3 to 0.3	V
THTH Pin Voltage	$V_{THTH}$		-0.3 to 7	V
Ambient Operating Temperature Range	$T_A$	Range K	-40 to 125	°C
		Range S	-20 to 85	°C
Junction Operating Temperature Range	$T_J$		-40 to 150	°C
Storage Temperature Range	$T_{stg}$		-55 to 150	°C
ESD Rating, Human Body Model		AEC-Q100-002, all pins	2000	V
ESD Rating, Charged Device Model		AEC-Q100-011, all pins	1050	V

\*With respect to GND.

## THERMAL CHARACTERISTICS\*: May require derating at maximum conditions; see application section for optimization

Characteristic	Symbol	Test Conditions*	Value	Unit
Package Thermal Resistance (Junction to Ambient)	$R_{\theta JA}$	On 4-layer PCB based on JEDEC standard	35	°C/W
		On 2-layer generic test PCB with 0.8 in. <sup>2</sup> of copper area each side	62	°C/W
Package Thermal Resistance (Junction to Pad)	$R_{\theta JP}$		2	°C/W

\*Additional thermal information available on the Allegro website.

FUNCTIONAL BLOCK DIAGRAM

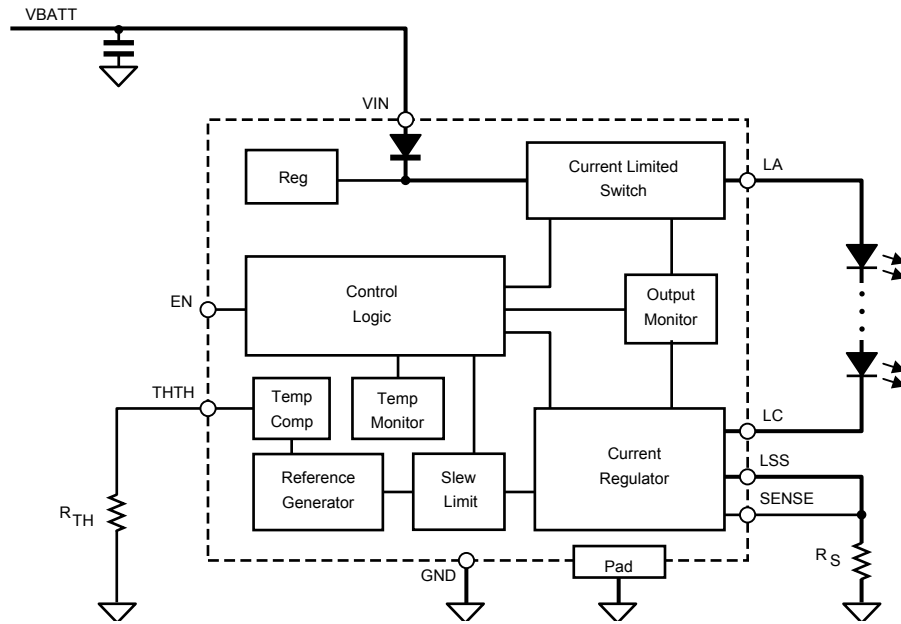

Pinout Diagram

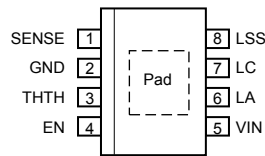

Terminal List Table

Number	Name	Description
1	SENSE	Current sense input
2	GND	Ground reference
3	THTH	Thermal threshold input
4	EN	Enable input
5	VIN	Main supply
6	LA	LED anode (+) connection
7	LC	LED cathode (-) connection
8	LSS	Low-side sense connection
9	Pad	Exposed pad for enhanced thermal dissipation

**ELECTRICAL CHARACTERISTICS:** Valid at  $T_J = -40^{\circ}\text{C}$  to  $150^{\circ}\text{C}$ ,  $V_{IN} = 7$  to  $40$  V, unless noted otherwise

Characteristics	Symbol	Test Conditions	Min.	Typ.	Max.	Units
<b>SUPPLY AND REFERENCE</b>						
$V_{IN}$ Functional Operating Range <sup>[1]</sup>	$V_{IN}$		6	–	40	V
$V_{IN}$ Quiescent Current	$I_{INQ}$	$I_{LA}, I_{LC}$ unconnected	–	–	4	mA
$V_{IN}$ Shutdown Current	$I_{INS}$	$EN < 400$ mV	–	1	10	$\mu\text{A}$
Startup Time	$t_{ON}$	$EN$ 2 V to 35 mA $I_{LC}$	9	18	27	$\mu\text{s}$
<b>CURRENT REGULATION</b>						
Maximum Current Sink	$I_{LCmax}$	$R_S = 250$ m $\Omega$ , $V_{IN} - V_{LA} > 2$ V	350	–	–	mA
Current Sink	$I_{LC}$	$R_S = 286$ m $\Omega$ , $V_{IN} - V_{LA} > 2$ V	333	350	367	mA
Current Sink Accuracy	$err_{ILC}$	$100$ mA $< I_{LC} < 350$ mA	–5	$\pm 4$	5	%
SENSE Reference Voltage	$V_{SENREF}$	$260$ m $\Omega < R_S < 1\Omega$	97	102	107	mV
Switch Dropout Voltage	$V_{DO}$	$V_{IN} - V_{LA}$ , $I_{LOAD} = 350$ mA	–	2.25	2.35	V
		$V_{IN} - V_{LA}$ , $I_{LOAD} = 150$ mA	–	1.35	1.4	V
Regulator Saturation Voltage	$V_{SAT}$	$V_{LC} - V_{SENSE}$ , $I_{LOAD} = 350$ mA	–	500	550	mV
		$V_{LC} - V_{SENSE}$ , $I_{LOAD} = 150$ mA	–	250	275	mV
Output Current Slew Time	$t_r$	Current rising from 10% to 90%	50	80	120	$\mu\text{s}$
		Current falling from 90% to 10%	60	100	150	$\mu\text{s}$
<b>LOGIC INPUT</b>						
Input Low Voltage	$V_{IL}$		–	–	0.8	V
Input High Voltage	$V_{IH}$		2	–	–	V
Input Hysteresis	$V_{Ihys}$		150	350	–	mV
<b>PROTECTION</b>						
Switch Overcurrent Trip Level	$I_{LAOC}$		–600	–500	–400	mA
Overcurrent Detection Time <sup>[2]</sup>	$t_{OCD}$	From detection to $I_{SCU} > -1.2$ mA	–	3	–	$\mu\text{s}$
Switch Current Limit	$I_{LALIM}$		–	$1.5 \times I_{LAOC}$	–	mA
LC Short Circuit Release Voltage	$V_{SCCR}$	Measured at $V_{LC}$ , when rising	1.0	1.2	1.4	V
Short Circuit Source Current <sup>[2]</sup>	$I_{SCU}$	When short is detected	–1.5	–1.1	–0.7	mA
Thermal Monitor Activation Temperature	$T_{JM}$	$T_J$ at $I_{LC} = 90\%$ , THTH open	90	105	120	$^{\circ}\text{C}$
Thermal Monitor Low Current Temperature	$T_{JL}$	$T_J$ at $I_{LC} = 25\%$ , THTH open	110	130	150	$^{\circ}\text{C}$
Overtemperature Shutdown Threshold	$T_{JF}$	Temperature increasing	–	165	–	$^{\circ}\text{C}$
Overtemperature Hysteresis	$T_{Jhys}$	Recovery = $T_{JF} - T_{Jhys}$	–	15	–	$^{\circ}\text{C}$

<sup>[1]</sup> Functions correctly, but parameters are not guaranteed, below the general limit (7 V).

<sup>[2]</sup> For input and output current specifications, negative current is defined as coming out of (sourcing) the specified device pin.

## FUNCTIONAL DESCRIPTION

The A6260 is a linear current regulator that is designed to provide drive current and protection for series-connected, high brightness LEDs in automotive applications. It provides programmable current output at load voltages up to 3 V below the main supply voltage. For automotive applications optimum performance is achieved when driving 1 to 3 LEDs at currents up to 350 mA.

The LED current is set by a single low-power sense resistor and the LED brightness can be further controlled by a PWM input to the EN pin. The EN input can also be used as an on/off switched input and the A6260 will enter a low current (<10  $\mu$ A) sleep mode if EN is held low.

For incandescent replacement configurations, the EN input can be connected directly to the VIN pin with the supply to VIN controlled by a simple on/off switch.

The LEDs and the regulator are protected from excessive currents caused by short circuits to ground or supply or by reversal of the power supply connections.

Integrated thermal management circuits can be used to reduce the regulated current level at high temperatures to limit power dissipation.

### Pin Functions

**VIN Pin.** Supply to the control circuit. A small-value ceramic bypass capacitor (typically 100 nF) should be connected from close to this pin to the GND pin.

**GND Pin.** Ground reference connection. Should be connected directly to the negative supply as close as possible to the bottom (ground connection) of the sense resistor.

**EN Pin.** Logic input to enable operation. Can be used as a direct PWM input. Chip enters a low-power sleep mode when this pin is held low.

**THTH Pin.** Sets the thermal monitor threshold,  $T_{JM}$ , where the output current starts to be reduced with increasing temperature. When this pin is left open, the threshold temperature will typically be the specified default value. A resistor connected between THTH and GND can be used to increase the threshold temperature. A resistor connected between THTH and VIN can be used to decrease the threshold temperature. Connecting THTH directly to GND disables the thermal monitor function.

**LA Pin.** Switched and protected current source connected to the anode of the LEDs.

**LC Pin.** Controlled current sink connected to the cathode of the LEDs.

**LSS Pin.** Low-side current sink connection from the current regulator to power ground via a sense resistor. A current sense resistor (240 m $\Omega$  to 3  $\Omega$ ) is connected between LSS and power ground.

**SENSE Pin.** LED current sense input. The high impedance SENSE input should have an independent connection to the top (LSS connection side) of the sense resistor.

### LED Current Level

The LED current is controlled by the internal current regulator between the LC and LSS pins. This current, defined as the current into the LC pin,  $I_{LC}$ , is set by the value,  $R_S$ , of the sense resistor. The voltage across the sense resistor, measured between the SENSE pin and the GND pin, is compared to a reference voltage, nominally 102 mV, allowing the use of a low-value sense resistor with low power dissipation.

The LED current is thus defined as:

$$I_{LC} = V_{SENREF} / R_S \quad (1)$$

conversely:

$$R_S = V_{SENREF} / I_{LC}$$

The nominal output current settings,  $I_{LC}$ , versus the current setting resistor values,  $R_S$ , are given in the following table. The current level defined here is the 100% current level before any current reduction effects due to the temperature monitor, described later in this document.

Sense Resistor Selection

$I_{LC}$ (mA)	$R_S$ (m $\Omega$ )	$P_{D(RS)}$ (mW)	$I_{LC}$ (mA)	$R_S$ (m $\Omega$ )	$P_{D(RS)}$ (mW)
350	286	35	125	800	13
300	333	30	100	1000	10
250	400	25	70	1429	7
200	500	20	50	2000	5
150	667	15	35	2857	4

### Parallel Operation

The A6260 is a constant current controller, that is, it controls the output current irrespective of output voltage (within the compliance range). This allows the outputs of two or more A6260s to be connected in parallel (see figure 7, in the Applications Information section). In this configuration, each A6260 must have a dedicated sense resistor, which determines its share of the current provided to the LED.

## LED Brightness

Although the LED brightness can be controlled by changing the current (intensity) this may slightly affect the color or the color temperature of the light from the LED. When multiple LEDs are used, it is usually more desirable to control the brightness by switching the fixed LED current with a pulse width modulated signal. This allows the LED brightness to be set using a digital control input with little effect on the LED color.

In the A6260, the brightness level can be controlled by a PWM signal applied to the EN input. This controls both the low-side linear regulator and the high-side switch.

When EN is switched from high to low, the low-side regulator reduces the current to zero before allowing the high-side switch to turn off.

When EN is switched from low to high, the high-side switch is turned on before the low-side regulator increases the current to the full operating level.

To assist EMC, the rate of change of the LED current is limited and the current will rise and fall within the limits ( $t_r$ ,  $t_f$ ) defined in the Electrical Characteristics table.

Note that EN can be used for PWM dimming even when the high-side switch is bypassed. (See figure 7(d)).

## Sleep Mode

When EN is held low, the A6260 will be in shutdown mode and all internal circuits will be in a low-power sleep mode. In this mode, the input current,  $I_{INS}$ , will be less than 10  $\mu$ A. This means that the complete circuit, including LEDs, may remain connected

to the power supply under all conditions.

## Safety Features

The circuit includes several features to ensure safe operation and to protect the LEDs and the A6260:

- The high-side switch between VIN and LA has overcurrent detection and a current limiter. It assumes that a short circuit is present if the current exceeds the trip value,  $I_{LAOC}$ , for longer than the overcurrent detection time,  $t_{OCD}$ .
- The current regulator between LC and LSS provides a natural current limit due to the regulation.
- The thermal monitor reduces the regulated current as the temperature rises.
- Thermal shutdown completely disables the outputs under extreme overtemperature conditions.

## Short Circuit Detection

A total of five short circuit conditions can exist as illustrated in figure 1.

**LA Short to Supply** (figure 1a) This condition is permitted because the current remains regulated by the current sink. This configuration may also be used in applications with low supply voltages (see figure 4d in the Applications Information section).

**LA Short to Ground** (figure 1b) This condition is detected when the high-side switch current exceeds the trip value,  $I_{LAOC}$ , for longer than the overcurrent detection time,  $t_{OCD}$  (3  $\mu$ s typical). When a short is detected, the switch and the regulator are both disabled. When the voltage at LC drops below the short release voltage,  $V_{SCCR}$ , a low value current,  $I_{SCU}$  (1.1 mA typical), is then sourced from LA to provide a short circuit monitor. When

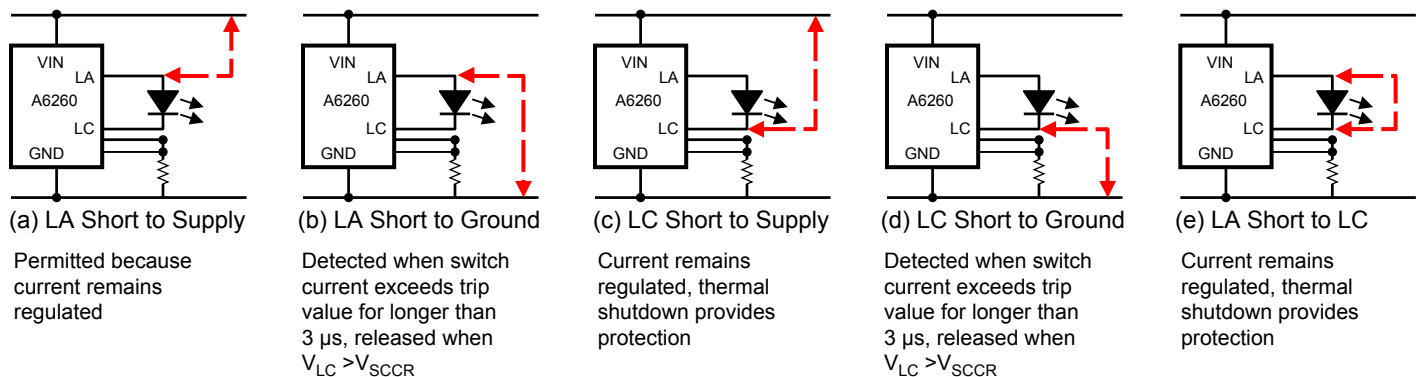

Figure 1. Short circuit conditions detected

the short circuit is removed the short circuit source current,  $I_{SCU}$ , pulls the voltage at the LC pin above  $V_{SCCR}$ , and the switch and regulator are re-enabled.

**LC Short to Supply** (figure 1c) In this condition, the current into the LC pin remains regulated but the power dissipated in the A6260 increases. This higher dissipation causes the thermal monitor to reduce the current to protect the regulator. In extreme cases, or in cases where the thermal monitor is disabled, the increased dissipation may cause temperature to reach the thermal shutdown level, at which point the regulator will be disabled.

**LC Short to Ground** (figure 1d) This condition is detected when the high-side switch exceeds the trip value,  $I_{LAOC}$ , for longer than the overcurrent detection time,  $t_{OCD}$  (3  $\mu$ s typical). When a short is detected, the switch and the regulator are both disabled. When the voltage at LC drops below the short release voltage,  $V_{SCCR}$ , a low value current,  $I_{SCU}$  (1.1 mA typical), is then sourced from LA to provide a short circuit monitor. When the short circuit is removed,  $I_{SCU}$  pulls the voltage at the LC pin above  $V_{SCCR}$ , and the switch and regulator are re-enabled.

**LA Short to LC** (figure 1e) This condition is effectively the same as the LC Short-to-Supply condition. In this condition, the current into the LC pin remains regulated but the power dissipated in the A6260 increases. This higher dissipation causes the thermal monitor to reduce the current to protect the regulator. In extreme cases, or in cases where the thermal monitor is disabled, the increased dissipation may cause temperature to reach the thermal shutdown level, at which point the regulator will be disabled.

## Temperature Monitor

The primary function of the temperature monitor included in the A6260 is to limit the power dissipation of the A6260 and maintain the junction temperature below the maximum. However, it can also be used to reduce LED current as LED temperature increases. This can be achieved by mounting the A6260 on the same thermal substrate as the LEDs, so that temperature rise in the LEDs would also affect the A6260. As the junction temperature of the A6260 increases, the integrated temperature monitor lowers the regulated current level, reducing the dissipated power in the A6260 and in the LEDs. As shown in figure 2, from the full 100% current level (see the LED Current Level section), current is reduced at a rate of 4%

per degree Celsius typically, until the point at which the current drops to 25% of the full level. The junction temperature at the 25% current level is defined as  $T_{JL}$ . If the temperature continues to rise above  $T_{JL}$ , the temperature monitor would continue to reduce current, but at a slower rate, until the temperature reaches the overtemperature shutdown temperature,  $T_{JF}$ .

The temperature at which the current reduction begins can be adjusted by changing the voltage on the THTH pin. When THTH is left open, the temperature at which the current reduction begins is typically 98°C. The thermal monitor activation temperature,  $T_{JM}$ , is defined in the Electrical Characteristics table at the 90% current level.

$T_{JM}$  can be increased by reducing the voltage at the THTH pin,  $V_{THTH}$ , and is defined as approximately:

$$T_{JM} = \frac{1.503 - V_{THTH}}{0.00363} \quad (2)$$

where  $T_{JM}$  is in °C.

A resistor connected between THTH and a reference supply greater than 2 V will increase  $V_{THTH}$  and reduce  $T_{JM}$ .

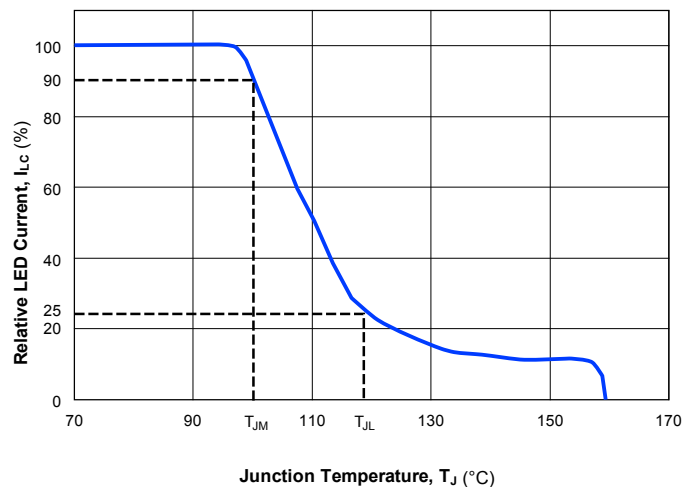

Figure 2. Temperature monitor current reduction

Figure 3 shows how the nominal value of the thermal monitor activation temperature varies with the voltage at THTH and with a pull-down resistor,  $R_{TH}$ , to GND or with a pull-up resistor,  $R_{TH}$ , to 5 V.

In extreme cases, if the chip temperature exceeds the overtemperature limit,  $T_{JF}$ , both the sink regulator and the source switch will be disabled. The temperature will continue to be monitored and the output re-activated when the temperature drops below the threshold provided by the specified hysteresis,  $T_{Jhys}$ .

### LED Current, Power Loss, and Junction Temperature Calculations

The maximum LED current the A6260 can deliver depends on voltage drop across the IC ( $V_{IN} - V_{LED}$ ), ambient temperature ( $T_A$ ), and thermal resistance ( $R_{\theta JA}$ ) from the IC junction to ambient.  $R_{\theta JA}$  depends on board construction, and air flow, and can be calculated as follows:

$$\text{Power loss across IC, } P_D = (V_{IN} - V_{LED} - V_{SENREF}) \times I_{LED} + V_{IN} \times I_{INQ} \quad (3)$$

if  $V_{SENREF} = 0.102 \text{ V}$ ,  $I_{INQ} = 3 \text{ mA}$  (typ), and given

$$\text{Junction temperature, } T_J = P_D \times R_{\theta JA} \quad (4)$$

then the  $R_{\theta JA}$  for the device, when mounted on a typical application board,  $30 \text{ }^\circ\text{C/W}$ . If thermal derating is used,  $I_{LED}$  current is reduced at a rate of 4% per  $^\circ\text{C}$  (typ) from  $T_{JM}$ .

Figure 4 shows LED current versus input voltage and figure 5 shows junction temperature versus input voltage. Test conditions were:

- $V_{LED} = 7 \text{ V}$ ,
- $I_{LED} = 350 \text{ mA}$ ,
- $T_A = 50^\circ\text{C}$ ,
- $R_{\theta JA} = 30 \text{ }^\circ\text{C/W}$ , and
- The THTH pin open for thermal monitor testing

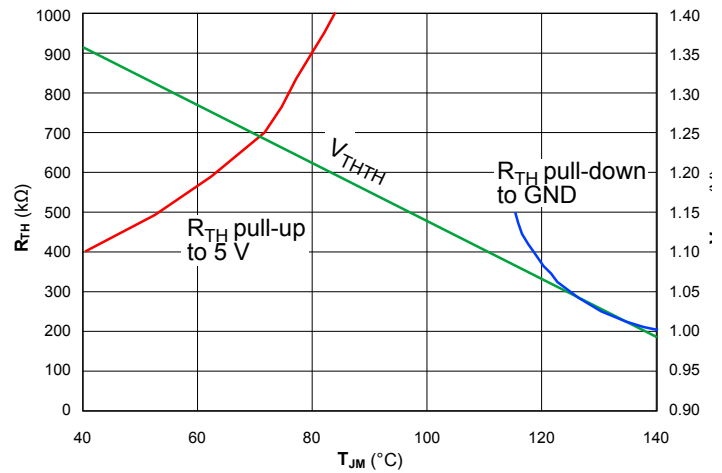

Figure 3.  $T_{JM}$  versus  $R_{TH}$  (pull-up or -down), and  $V_{THTH}$

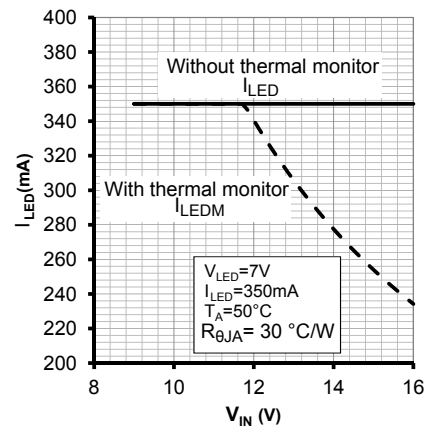

Figure 4. LED current,  $I_{LED}$ , versus input voltage,  $V_{IN}$ , both with and without thermal monitor

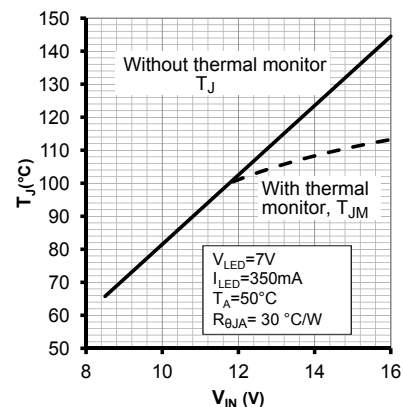

Figure 5. Junction temperature,  $T_J$ , versus input voltage,  $V_{IN}$ , both with and without thermal monitor



## Thermal Dissipation

The amount of heat that can pass from the silicon of the A6260 to the surrounding ambient environment depends on the thermal resistance of the structures connected to the A6260. The thermal resistance,  $R_{\theta JA}$ , is a measure of the temperature rise created by power dissipation and is usually measured in degrees Celsius per watt ( $^{\circ}C/W$ ).

The temperature rise,  $\Delta T$ , is calculated from the power dissipated,  $P_D$ , and the thermal resistance,  $R_{\theta JA}$ , as:

$$\Delta T = P_D \times R_{\theta JA} \quad (5)$$

A thermal resistance from silicon to ambient,  $R_{\theta JA}$ , of approximately  $35^{\circ}C/W$  can be achieved by mounting the A6260 on a standard FR4 double-sided printed circuit board (PCB) with a copper area of a few square inches on each side of the board under the A6260. Additional improvements in the range of 20% may be achieved by optimizing the PCB design.

## Optimizing Thermal Layout

The features of the printed circuit board, including heat conduction and adjacent thermal sources such as other components, have a very significant effect on the thermal performance of the device. To optimize thermal performance, the following should be taken into account:

- The device exposed thermal pad should be connected to as much copper area as is available.
- Copper thickness should be as high as possible (for example, 2 oz. or greater for higher power applications).
- The greater the quantity of thermal vias, the better the dissipation. If the expense of vias is a concern, studies have shown that concentrating the vias directly under the device in a tight pattern, as shown in figure 6, has the greatest effect.
- Additional exposed copper area on the opposite side of the board should be connected by means of the thermal vias. The copper should cover as much area as possible.
- Other thermal sources should be placed as remote from the device as possible

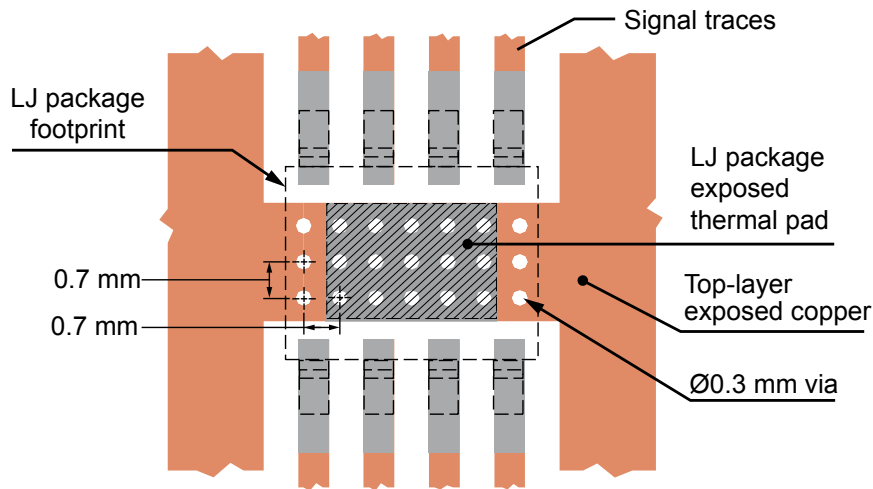

Figure 6. Suggested PCB layout for thermal optimization (maximum available bottom-layer copper recommended)

## APPLICATIONS INFORMATION

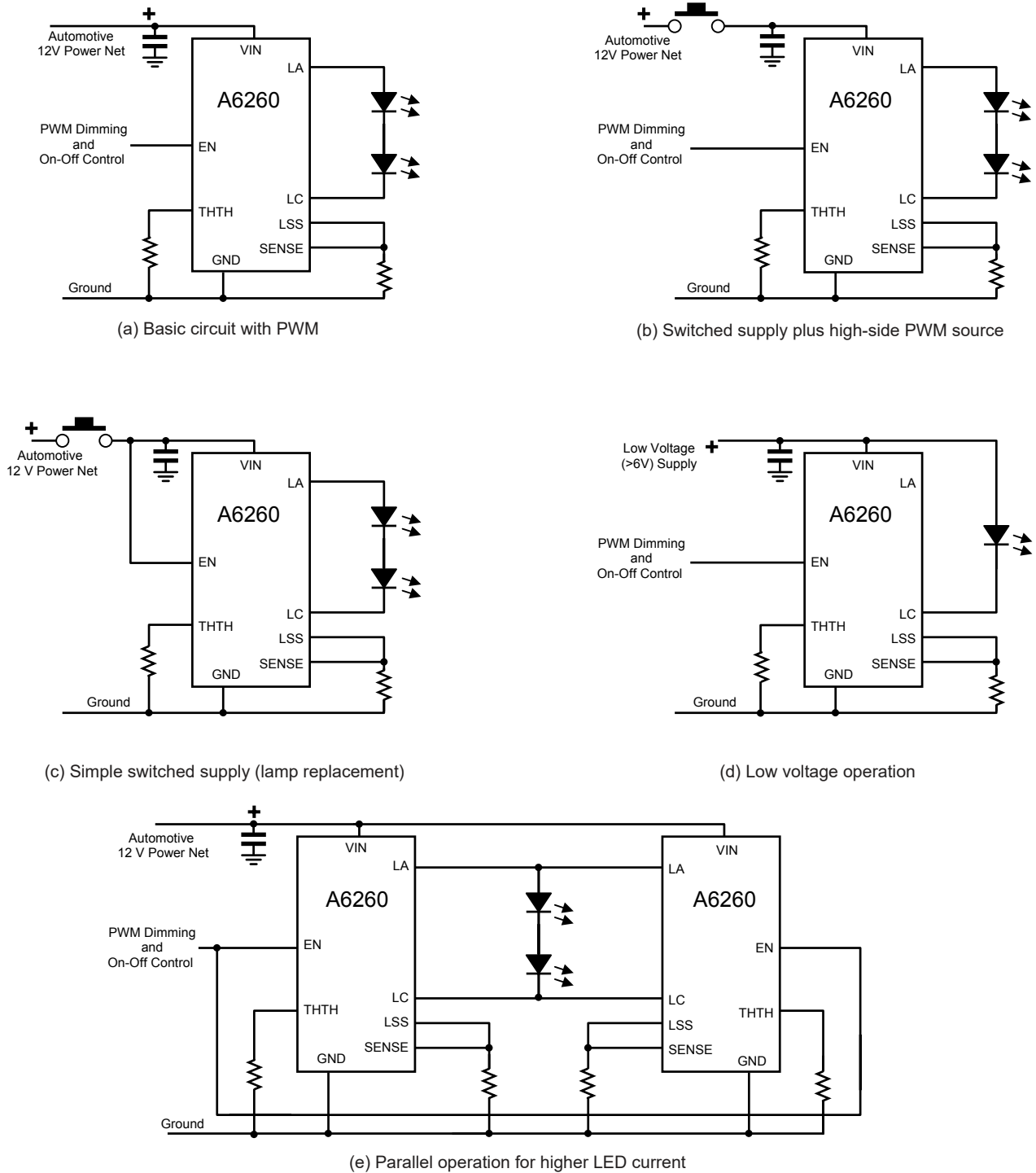

Figure 7. Typical applications circuits

Package LJ 8-Pin SOICN with Exposed Thermal Pad

For Reference Only – Not for Tooling Use

(Reference Allegro DWG-0000380, Rev. 2 and JEDEC MS-012BA)

Dimensions in millimeters – NOT TO SCALE

Dimensions exclusive of mold flash, gate burrs, and dambar protrusions

Exact case and lead configuration at supplier discretion within limits shown

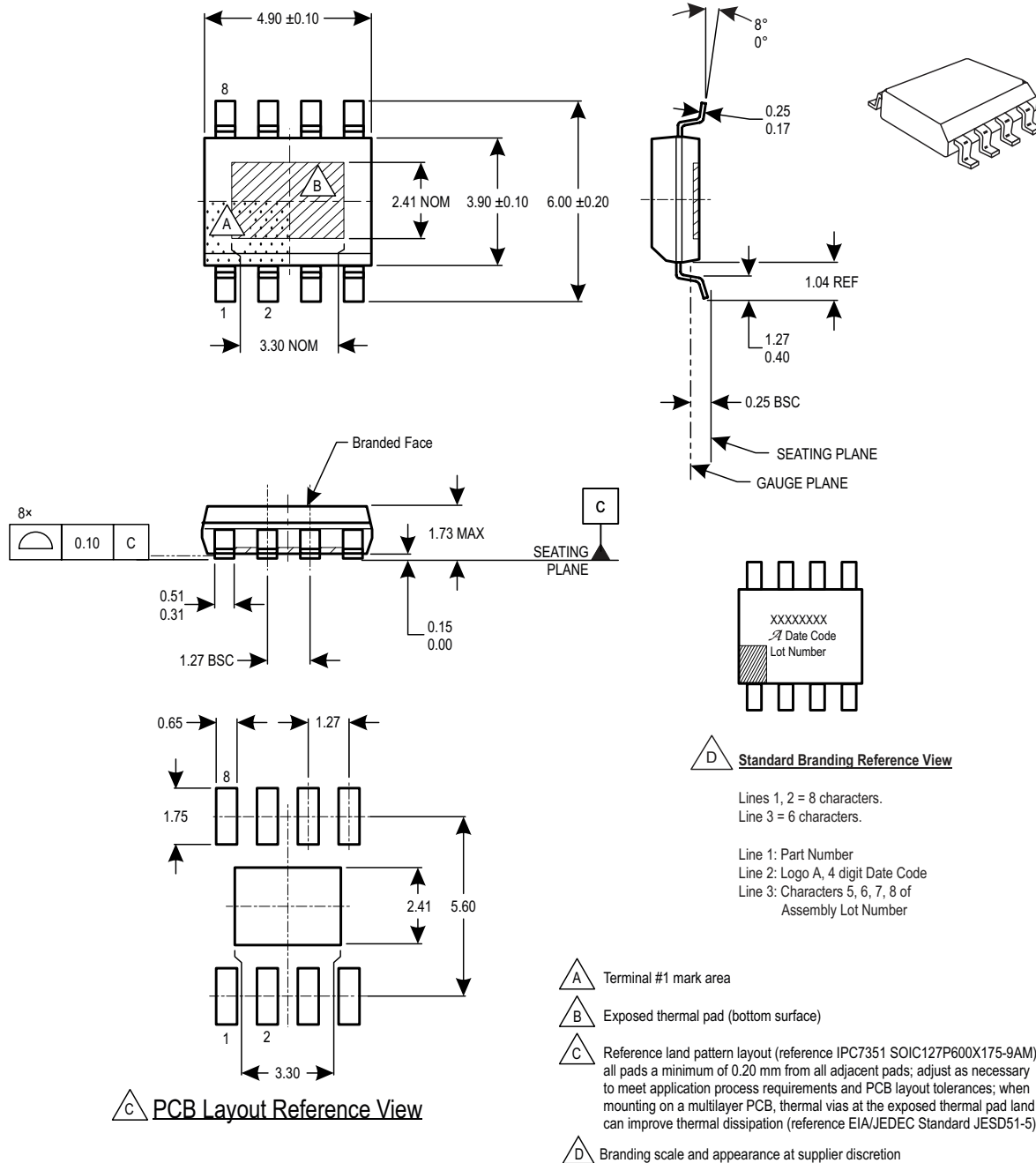

**REVISION HISTORY**

<b>Number</b>	<b>Date</b>	<b>Description</b>
7	September 12, 2013	Update functional description
8	May 28, 2020	Minor editorial updates
9	June 2, 2022	Updated package drawing (page 11) and minor editorial updates

Copyright 2022, Allegro MicroSystems.

Allegro MicroSystems reserves the right to make, from time to time, such departures from the detail specifications as may be required to permit improvements in the performance, reliability, or manufacturability of its products. Before placing an order, the user is cautioned to verify that the information being relied upon is current.

Allegro's products are not to be used in any devices or systems, including but not limited to life support devices or systems, in which a failure of Allegro's product can reasonably be expected to cause bodily harm.

The information included herein is believed to be accurate and reliable. However, Allegro MicroSystems assumes no responsibility for its use; nor for any infringement of patents or other rights of third parties which may result from its use.

Copies of this document are considered uncontrolled documents.

For the latest version of this document, visit our website:

[www.allegromicro.com](http://www.allegromicro.com)