

REF. -50 OPTION,  
CLAMP WASHER SCREW  
(WHERE APPLICABLE)

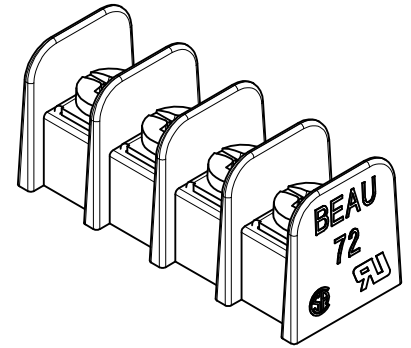

4 CIRCUIT SHOWN

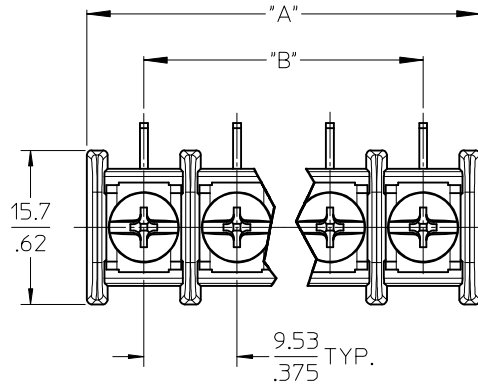
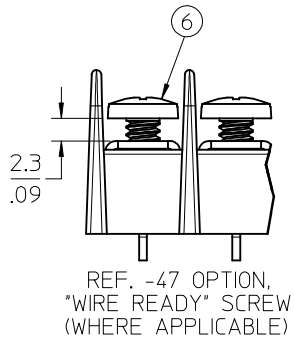

REF. -47 OPTION,  
'WIRE READY' SCREW  
(WHERE APPLICABLE)

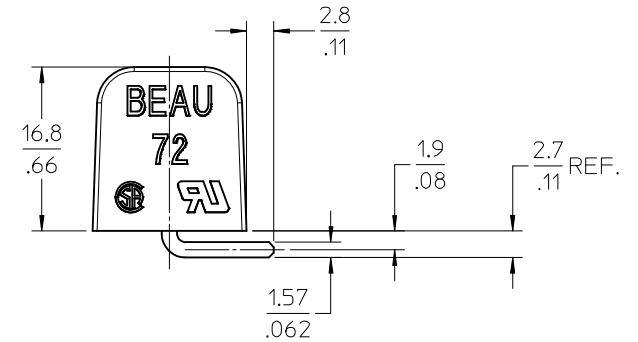
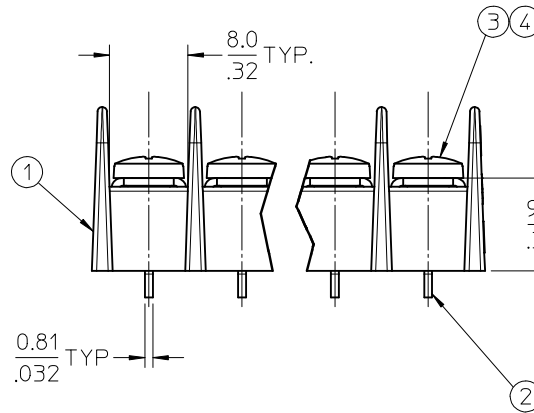

NOTES:

1. MATERIAL: SEE TABLE
2. FINISHES: SEE TABLE
3. "XX" REFERS TO THE QUANTITY OF CIRCUITS.
4. UL FILE# E48521, SEE SHEET 2.
5. CSA FILE# 025562, SEE SHEET 2.
6. INSULATOR IS UL 94 V-0
7. ALL COMPONENTS ARE ROHS COMPLIANT.

6	XX	SCREW #6-32 BHD, PH-SL, WRDY (-47 OPT)	STEEL	ZN, CLEAR CHROMATE	<b>FILE SAVE CHG ONLY</b> EC NO: WNA2010-0237 DT: DRW:NYC/CLYORK 2009/10/01 CHKD:DTITUS 2009/10/02 APPR:DTITUS 2009/10/05 REV DESCRIPTION	QUALITY SYMBOLS ▽=0 ▽=0	GENERAL TOLERANCES (UNLESS SPECIFIED) mm INCH 4 PLACES ± --- ± --- 3 PLACES ± --- ± .005 2 PLACES ± 0.13 ± .01 1 PLACE ± 0.25 ± --- ANGULAR ± 2 °	DIMENSION STYLE MM/IN DRAWN BY DATE C. YORK 2006/02/08 CHECKED BY DATE RDEROSS 2006/02/08 APPROVED BY DATE DTITUS 2009/10/02	SCALE 2:1 DESIGN UNITS INCH THIRD ANGLE PROJECTION	TITLE 9.53/.375 SR BTS ASY, PC RA, NO MTG
5	XX	SCREW&WASHER #6-32 PAN, PH-SL (-50 OPT)	STEEL	ZN, CLEAR CHROMATE						
4	XX	SCREW #6-32 BHD, PHIL-SLOT (-49 OPT)	BRASS	NICKEL PLATE						
3	XX	SCREW #6-32 BHD, PHIL-SLOT (STD.)	STEEL	ZN, CLEAR CHROMATE						
2	XX	TERMINAL, WW	BRASS	TIN PLATE						
1	1	INSULATOR, SR, NO MTG.	PBT, 30% GF	BLACK						
ITEM	QTY.	DESCRIPTION	MATERIAL	FINISH	DRAFT WHERE APPLICABLE MUST REMAIN WITHIN DIMENSIONS		MATERIAL NO. SEE CHART	DOCUMENT NO. SD-38721-001	SHEET NO. 1 OF 2	

NUMBER OF CIRCUITS "XX"	DIM. "A"		DIM. "B"		MATERIAL NO. WITH STD. SCREW (-C OPT.)	MATERIAL NO. WITH WIRE READY SCREW (-C-47 OPT.)	MATERIAL NO. WITH BRASS SCREW (-C-49 OPT.)	MATERIAL NO. W/CLAMP-WASHER SCREW (-C-50 OPT.)	UL & CSA REFERENCE NUMBER
02	21.1	[.83]	9.53	[.375]	38721-5302	38721-6202	38721-5602	38721-5902	72
03	30.7	[1.21]	19.05	[.750]	38721-5303	38721-6203	38721-5603	38721-5903	72
04	40.1	[1.58]	28.58	[1.125]	38721-5304	38721-6204	38721-5604	38721-5904	72
05	49.8	[1.96]	38.10	[1.500]	38721-5305	38721-6205	38721-5605	38721-5905	72
06	59.2	[2.33]	47.63	[1.875]	38721-5306	38721-6206	38721-5606	38721-5906	72
07	68.8	[2.71]	57.15	[2.250]	38721-5307	38721-6207	38721-5607	38721-5907	72
08	78.3	[3.08]	66.68	[2.625]	38721-5308	38721-6208	38721-5608	38721-5908	72
09	87.8	[3.46]	76.20	[3.000]	38721-5309	38721-6209	38721-5609	38721-5909	72
10	97.3	[3.83]	85.73	[3.375]	38721-5310	38721-6210	38721-5610	38721-5910	72
11	106.9	[4.21]	95.25	[3.750]	38721-5311	38721-6211	38721-5611	38721-5911	72
12	116.3	[4.58]	104.78	[4.125]	38721-5312	38721-6212	38721-5612	38721-5912	72
13	126.0	[4.96]	114.30	[4.500]	38721-5313	38721-6213	38721-5613	38721-5913	72
14	135.3	[5.33]	123.83	[4.875]	38721-5314	38721-6214	38721-5614	38721-5914	72
15	145.0	[5.71]	133.35	[5.250]	38721-5315	38721-6215	38721-5615	38721-5915	72
16	154.4	[6.08]	142.88	[5.625]	38721-5316	38721-6216	38721-5616	38721-5916	72
17	164.1	[6.46]	152.40	[6.000]	38721-5317	38721-6217	38721-5617	38721-5917	72
18	173.5	[6.83]	161.93	[6.375]	38721-5318	38721-6218	38721-5618	38721-5918	72
19	183.1	[7.21]	171.45	[6.750]	38721-5319	38721-6219	38721-5619	38721-5919	72
20	192.5	[7.58]	180.98	[7.125]	38721-5320	38721-6220	38721-5620	38721-5920	72
21	202.2	[7.96]	190.50	[7.500]	38721-5321	38721-6221	38721-5621	38721-5921	72
22	211.6	[8.33]	200.03	[7.875]	38721-5322	38721-6222	38721-5622	38721-5922	72
23	221.2	[8.71]	209.55	[8.250]	38721-5323	38721-6223	38721-5623	38721-5923	72
24	230.6	[9.08]	219.08	[8.625]	38721-5324	38721-6224	38721-5624	38721-5924	72
25	240.3	[9.46]	228.60	[9.000]	38721-5325	38721-6225	38721-5625	38721-5925	72
26	249.6	[9.83]	238.13	[9.375]	38721-5326	38721-6226	38721-5626	38721-5926	72



NOTES:

- 1 FOR UL OR CSA FILE, USE UL & CSA REFERENCE NO. PROVIDED IN CHART ALONG WITH THE INSTRUCTIONS BELOW.
- 2 FOR ASSEMBLY WITH CLAMP-WASHER SCREW, ADD -50 TO THE UL & CSA REFERENCE NO.

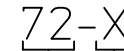

SERIES \_\_\_\_\_ OPTIONS (WHERE APPLICABLE)

UL & CSA FILE INSTRUCTIONS

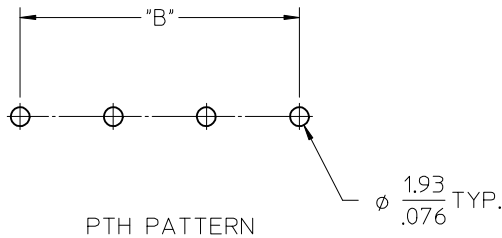

<b>UPDATE TABLE</b> EC NO: WNA2010-0237 DRAWN BY: C. YORK 2009/10/01 CHKD: DTITUS 2009/10/02 APPR: DTITUS 2009/10/05 REV:	QUALITY SYMBOLS ▽=0 ▽=0	GENERAL TOLERANCES (UNLESS SPECIFIED) mm INCH 4 PLACES ± --- ± --- 3 PLACES ± --- ± .005 2 PLACES ± 0.13 ± .01 1 PLACE ± 0.25 ± --- ANGULAR ± 2 °	DIMENSION STYLE MM/IN DRAWN BY: C. YORK DATE: 2006/02/08 CHECKED BY: RDEROSS DATE: 2006/02/08 APPROVED BY: DTITUS DATE: 2009/10/02	SCALE: 2:1 DESIGN UNITS: INCH THIRD ANGLE PROJECTION	TITLE: 9.53/.375 SR BTS ASY, PC RA, NO MTG
	DRAFT WHERE APPLICABLE MUST REMAIN WITHIN DIMENSIONS	MATERIAL NO. SEE CHART	MOLEX INCORPORATED	DOCUMENT NO. SD-38721-001	SHEET NO. 2 OF 2
	THIS DRAWING CONTAINS INFORMATION THAT IS PROPRIETARY TO MOLEX INCORPORATED AND SHOULD NOT BE USED WITHOUT WRITTEN PERMISSION				
	MILEX INCORPORATED				