

500 mA LDO Regulator (Operating Voltage up to 24 V) for Automotive Applications

NO.EC-151-140513

OUTLINE

The R1500x is a positive voltage regulator (VR) IC developed with CMOS process technology. The R1500xxxxB has features of high input voltage operating, 500 mA output current drive, and low supply current.

A DMOS transistor is used for the driver, high voltage operating and low on resistance (0.6Ω at $V_{SET} = 10 \text{ V}$) device is realized. A standard regulator circuit with a current limit circuit and a thermal shutdown circuit are built in the R1500x.

As the operating temperature range is from -40°C to 105°C and maximum input voltage is up to 24 V, the R1500x is suitable for the constant voltage source for car accessories.

The regulator output voltage is fixed in the R1500x. Output voltage accuracy is $\pm 2.0\%$ and output voltage range is from 3.0 V to 12.0 V with a step of 0.1 V. The chip enable pin realizes ultra low supply current standby mode.

The R1500x is offered in a 5-pin SOT-89-5 package which can achieve the smallest possible footprint solution on boards where area is limited.

* The DMOS (Double Diffused MOS) transistor adopted by R1500x is characterized by a double diffusion structure which comprises a low density n-type (channel) diffused layer and a high density p-type (sources) diffused layer from the edge of the gate electrode. The R1500x possesses outstanding properties of high operating voltage and low on-resistance, which have been achieved by the channel length scaled down to submicron dimensions and decreased thickness of the gate oxide film.

FEATURES

- Input Voltage Range (Maximum Rating)..... 4.0 V to 24.0 V (36 V)
- Operating Temperature range..... -40°C to 105°C
- Supply Current..... Typ. 70 μA
- Standby Current..... Typ. 0.1 μA
- Ripple Rejection Typ. 60 dB ($V_{SET} = 5.0 \text{ V}$)
- Temperature-Drift Coefficient of Output Voltage..... Typ. $\pm 100 \text{ ppm}/^\circ\text{C}$
- Output Current Min. 500 mA ($V_{IN} = V_{SET} + 1 \text{ V}$)
- Line Regulation..... Typ. 0.05%/V
- Output Voltage Accuracy $\pm 2\%$
- Output Voltage 3.0 V to 12.0 V (0.1 V step)
- Package SOT-89-5
- Built-in Current Limit Circuit..... Typ. 65 mA
- Built-in Fold-Back Circuit
- Built-in Thermal Shutdown Circuit

APPLICATIONS

- Power source for accessories such as car audios, car navigation systems, and ETC systems
- Power source for ECUs such as EV inverter and battery charge control unit

R1500H

NO.EC-151-140513

BLOCK DIAGRAM

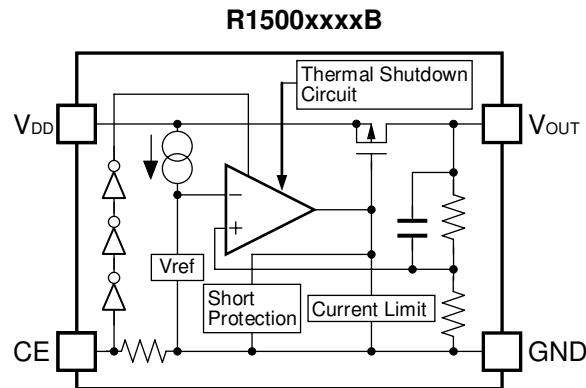

SELECTION GUIDE

The output voltage for the IC can be selected at the user's request.

Product Name	Package	Quantity per Reel	Pb Free	Halogen Free
R1500HxxxB-T1-#E	SOT-89-5	1,000 pcs	Yes	Yes

xxx: The set output voltage (V_{SET}) can be designated in the range from 3.0 V (030) to 12.0 V (120) in 0.1 V step.

#: Specify Automotive Class Code

	Operating Temperature Range	Guaranteed Specs Temperature Range	Screening
A	-40°C to 105°C	25°C	High Temperature
J	-40°C to 105°C	25°C	High and Low Temperature

PIN DESCRIPTION

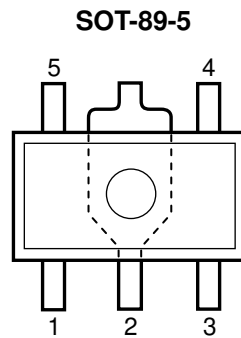

SOT-89-5

Pin No.	Symbol	Description
1	V _{DD}	Input Pin
2	GND*	Ground Pin
3	GND*	Ground Pin
4	CE	Chip Enable Pin ("H" Active)
5	V _{OUT}	Output Pin

* The GND pin must be wired together when it is mounted on board.

R1500H

NO.EC-151-140513

ABSOLUTE MAXIMUM RATINGS

Symbol	Item	Rating	Unit
V_{IN}	Input Voltage	36	V
V_{CE}	Input Voltage (CE Pin)	-0.3 to $V_{IN} \leq 36$	V
V_{OUT}	Output Voltage	-0.3 to $V_{IN} \leq 36$	V
P_D	Power Dissipation (SOT-89-5)*	Standard Land Pattern	1120
		High Wattage Land Pattern	1620
T_j	Junction Temperature	-40 to 150	°C
T_{stg}	Storage Temperature Range	-55 to 150	°C

* Refer to *PACKAGE INFORMATION* for detailed information.

ABSOLUTE MAXIMUM RATINGS

Electronic and mechanical stress momentarily exceeded absolute maximum ratings may cause the permanent damages and may degrade the life time and safety for both device and system using the device in the field.
The functional operation at or over these absolute maximum ratings is not assured.

RECOMMENDED OPERATING CONDITIONS

Symbol	Item	Rating	Unit
V_{IN}	Input Voltage	4.0 to 24.0	V
T_a	Operating Temperature Range	-40 to 105	°C

RECOMMENDED OPERATING CONDITIONS

All of electronic equipment should be designed that the mounted semiconductor devices operate within the recommended operating conditions. The semiconductor devices cannot operate normally over the recommended operating conditions, even if when they are used over such conditions by momentary electronic noise or surge. And the semiconductor devices may receive serious damage when they continue to operate over the recommended operating conditions.

ELECTRICAL CHARACTERISTICS

$V_{IN} = V_{SET} + 1.0 \text{ V}$, $C_{IN} = 0.47 \mu\text{F}$, $C_{OUT} = 10 \mu\text{F}$, unless otherwise noted.

The specifications surrounded by are guaranteed by design engineering at $-40^\circ\text{C} \leq T_a \leq 105^\circ\text{C}$.

R1500xxxxB

($T_a = 25^\circ\text{C}$)

Symbol	Item	Conditions	Min.	Typ.	Max.	Unit	
V_{OUT}	Output Voltage	$I_{OUT} = 100 \text{ mA}$	$T_a = 25^\circ\text{C}$	x 0.98		x 1.02	V
			$-40^\circ\text{C} \leq T_a \leq 105^\circ\text{C}$	x 0.965		x 1.035	
I_{LIM}	Output Current Limit		500			mA	
I_{SS}	Supply Current	$V_{IN} = V_{CE}$		70	140	μA	
$I_{standby}$	Standby Current	$V_{IN} = 24 \text{ V}$		0.1	1.0	μA	
$\frac{\Delta V_{OUT}}{\Delta I_{OUT}}$	Load Regulation	$V_{IN} = V_{SET} + 2.0 \text{ V}$ $0.1 \text{ mA} \leq I_{OUT} \leq 200 \text{ mA}$		25	60	mV	
$\frac{\Delta V_{OUT}}{\Delta V_{IN}}$	Line Regulation	$V_{SET} + 1 \text{ V} \leq V_{IN} \leq 24 \text{ V}$ $I_{OUT} = 10 \text{ mA}$		0.05	0.1	%/V	
V_{DIF}	Dropout Voltage	$I_{OUT} = 200 \text{ mA}$	Refer to the <i>Product-specific Electrical Characteristics</i>				
I_{SC}	Short Current Limit	$V_{OUT} = 0 \text{ V}$		65		mA	
V_{CEH}	CE Input Voltage "H"		2.0		V_{IN}	V	
V_{CEL}	CE Input Voltage "L"		0		0.4	V	
T_{TSD}	Thermal Shutdown Temperature	Junction Temperature	150	170		$^\circ\text{C}$	
T_{TSR}	Thermal Shutdown Released Temperature	Junction Temperature		145		$^\circ\text{C}$	

All test items listed under Electrical Characteristics are done under the pulse load condition ($T_j \approx T_a = 25^\circ\text{C}$).

R1500H

NO.EC-151-140513

Product-specific Electrical CharacteristicsThe specifications surrounded by are guaranteed by design engineering at $-40^{\circ}\text{C} \leq T_a \leq 105^{\circ}\text{C}$.

(Ta = 25°C)

Product Name	V _{OUT} [V]					V _{DIF} [V]	
	(Ta = 25°C)			(-40°C ≤ Ta ≤ 105°C)		TYP.	MAX.
	MIN.	TYP.	MAX.	TYP.	MAX.		
R1500H030B	2.940	3.000	3.060	2.895	3.105	0.135	0.225
R1500H031B	3.038	3.100	3.162	2.992	3.208		
R1500H032B	3.136	3.200	3.264	3.088	3.312		
R1500H033B	3.234	3.300	3.366	3.185	3.415		
R1500H034B	3.332	3.400	3.468	3.281	3.519		
R1500H035B	3.430	3.500	3.570	3.378	3.622		
R1500H036B	3.528	3.600	3.672	3.474	3.726		
R1500H037B	3.626	3.700	3.774	3.571	3.829		
R1500H038B	3.724	3.800	3.876	3.667	3.933		
R1500H039B	3.822	3.900	3.978	3.764	4.036		
R1500H040B	3.920	4.000	4.080	3.860	4.140		
R1500H041B	4.018	4.100	4.182	3.957	4.243		
R1500H042B	4.116	4.200	4.284	4.053	4.347		
R1500H043B	4.214	4.300	4.386	4.150	4.450		
R1500H044B	4.312	4.400	4.488	4.246	4.554		
R1500H045B	4.410	4.500	4.590	4.343	4.657		
R1500H046B	4.508	4.600	4.692	4.439	4.761		
R1500H047B	4.606	4.700	4.794	4.536	4.864		
R1500H048B	4.704	4.800	4.896	4.632	4.968		
R1500H049B	4.802	4.900	4.998	4.729	5.071		
R1500H050B	4.900	5.000	5.100	4.825	5.175		
R1500H051B	4.998	5.100	5.202	4.922	5.278		
R1500H052B	5.096	5.200	5.304	5.018	5.382		
R1500H053B	5.194	5.300	5.406	5.115	5.485		
R1500H054B	5.292	5.400	5.508	5.211	5.589		
R1500H055B	5.390	5.500	5.610	5.308	5.692		
R1500H056B	5.488	5.600	5.712	5.404	5.796		
R1500H057B	5.586	5.700	5.814	5.501	5.899		
R1500H058B	5.684	5.800	5.916	5.597	6.003		
R1500H059B	5.782	5.900	6.018	5.694	6.106		
						0.115	0.180

The specifications surrounded by are guaranteed by design engineering at $-40^{\circ}\text{C} \leq T_a \leq 105^{\circ}\text{C}$.

($T_a = 25^{\circ}\text{C}$)

Product Name	V_{OUT} [V]					V_{DIF} [V]	
	$(T_a = 25^{\circ}\text{C})$			$(-40^{\circ}\text{C} \leq T_a \leq 105^{\circ}\text{C})$		TYP.	MAX.
	MIN.	TYP.	MAX.	MIN.	MAX.		
R1500H060B	5.880	6.000	6.120	5.790	6.210	0.115	0.180
R1500H061B	5.978	6.100	6.222	5.887	6.313		
R1500H062B	6.076	6.200	6.324	5.983	6.417		
R1500H063B	6.174	6.300	6.426	6.080	6.520		
R1500H064B	6.272	6.400	6.528	6.176	6.624		
R1500H065B	6.370	6.500	6.630	6.273	6.727		
R1500H066B	6.468	6.600	6.732	6.369	6.831		
R1500H067B	6.566	6.700	6.834	6.466	6.934		
R1500H068B	6.664	6.800	6.936	6.562	7.038		
R1500H069B	6.762	6.900	7.038	6.659	7.141		
R1500H070B	6.860	7.000	7.140	6.755	7.245		
R1500H071B	6.958	7.100	7.242	6.852	7.348		
R1500H072B	7.056	7.200	7.344	6.948	7.452		
R1500H073B	7.154	7.300	7.446	7.045	7.555		
R1500H074B	7.252	7.400	7.548	7.141	7.659		
R1500H075B	7.351	7.500	7.650	7.238	7.762		
R1500H076B	7.448	7.600	7.752	7.334	7.866		
R1500H077B	7.546	7.700	7.854	7.431	7.969		
R1500H078B	7.645	7.800	7.956	7.528	8.073		
R1500H079B	7.743	7.900	8.058	7.624	8.176		
R1500H080B	7.841	8.000	8.160	7.721	8.280		
R1500H081B	7.938	8.100	8.262	7.817	8.383		
R1500H082B	8.037	8.200	8.364	7.914	8.487		
R1500H083B	8.135	8.300	8.466	8.010	8.590		
R1500H084B	8.233	8.400	8.568	8.107	8.694		
R1500H085B	8.331	8.500	8.670	8.203	8.797		
R1500H086B	8.429	8.600	8.772	8.300	8.901		
R1500H087B	8.527	8.700	8.874	8.396	9.004		
R1500H088B	8.625	8.800	8.976	8.493	9.108		
R1500H089B	8.723	8.900	9.078	8.589	9.211		

R1500H

NO.EC-151-140513

The specifications surrounded by are guaranteed by design engineering at $-40^{\circ}\text{C} \leq T_a \leq 105^{\circ}\text{C}$.

(Ta = 25°C)

Product Name	V _{OUT} [V]					V _{DIF} [V]	
	(Ta = 25°C)			(-40°C ≤ Ta ≤ 105°C)		TYP.	MAX.
	MIN.	TYP.	MAX.	MIN.	MAX.		
R1500H090B	8.821	9.000	9.180	8.686	9.315	0.095	0.155
R1500H091B	8.919	9.100	9.282	8.782	9.418		
R1500H092B	9.017	9.200	9.384	8.879	9.522		
R1500H093B	9.115	9.300	9.486	8.975	9.625		
R1500H094B	9.213	9.400	9.588	9.072	9.729		
R1500H095B	9.311	9.500	9.690	9.168	9.832		
R1500H096B	9.409	9.600	9.792	9.265	9.936		
R1500H097B	9.507	9.700	9.894	9.361	10.039		
R1500H098B	9.605	9.800	9.996	9.458	10.143		
R1500H099B	9.703	9.900	10.098	9.554	10.246		
R1500H100B	9.800	10.000	10.200	9.650	10.350		
R1500H101B	9.898	10.100	10.302	9.747	10.453		
R1500H102B	9.996	10.200	10.404	9.843	10.557		
R1500H103B	10.094	10.300	10.506	9.940	10.660		
R1500H104B	10.192	10.400	10.608	10.036	10.764		
R1500H105B	10.290	10.500	10.710	10.133	10.867		
R1500H106B	10.388	10.600	10.812	10.229	10.971		
R1500H107B	10.486	10.700	10.914	10.326	11.074		
R1500H108B	10.584	10.800	11.016	10.422	11.178		
R1500H109B	10.682	10.900	11.118	10.519	11.281		
R1500H110B	10.780	11.000	11.220	10.615	11.385		
R1500H111B	10.878	11.100	11.322	10.712	11.488		
R1500H112B	10.976	11.200	11.424	10.808	11.592		
R1500H113B	11.074	11.300	11.526	10.905	11.695		
R1500H114B	11.172	11.400	11.628	11.001	11.799		
R1500H115B	11.270	11.500	11.730	11.098	11.902		
R1500H116B	11.368	11.600	11.832	11.194	12.006		
R1500H117B	11.466	11.700	11.934	11.291	12.109		
R1500H118B	11.564	11.800	12.036	11.387	12.213		
R1500H119B	11.662	11.900	12.138	11.484	12.316		
R1500H120B	11.760	12.000	12.240	11.580	12.420		

TYPICAL APPLICATION

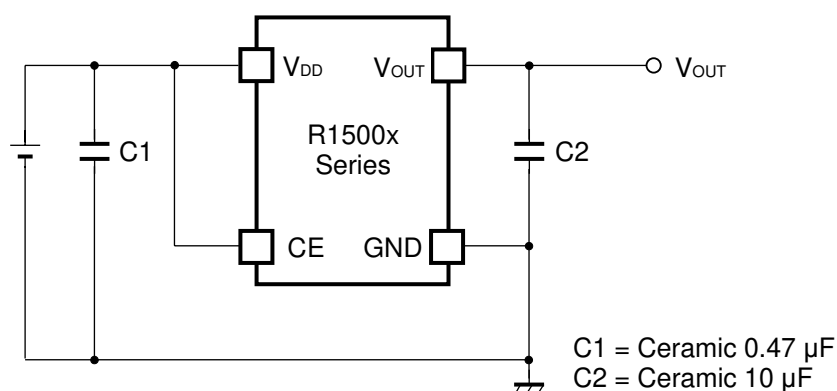

External Components

Symbol	Description
C2 (C _{OUT})	10 μ F, Ceramic Capacitor Murata GRM32DB31E106K (size: 3225)

TECHNICAL NOTES

When using these ICs, consider the following points:

Phase Compensation

In these ICs, phase compensation is made for securing stable operation even if the load current is varied. For this purpose, use a capacitor C2 with good frequency characteristics and ESR (Equivalent Series Resistance).

If you use a tantalum type capacitor and ESR value of the capacitor is large, output might be unstable. Evaluate your circuit with considering frequency characteristics.

Depending on the capacitor size, manufacturer, and part number, the bias characteristics and temperature characteristics are different. Evaluate the circuit with actual using capacitors.

PCB Layout

Make V_{DD} and GND lines sufficient. If their impedance is high, noise pickup or unstable operation may result. Connect a capacitor C1 with a capacitance value as much as 0.47 μ F or more between V_{DD} and GND pin, and as close as possible to the pins.

Set external components, especially the output capacitor C2, as close as possible to the ICs, and make wiring as short as possible.

No. 2 pin and No. 3 pin must be wired to the GND plane when it is mounted on board.

Thermal Shutdown

There is the built-in thermal-shutdown function in R1500x. It discontinues operation of the IC when the junction temperature becomes over 170°C (Typ.) and IC re-operates when the junction temperature under 145°C. If the temperature increasing keeps the IC repeats ON and OFF operating. The output becomes the pulse condition.

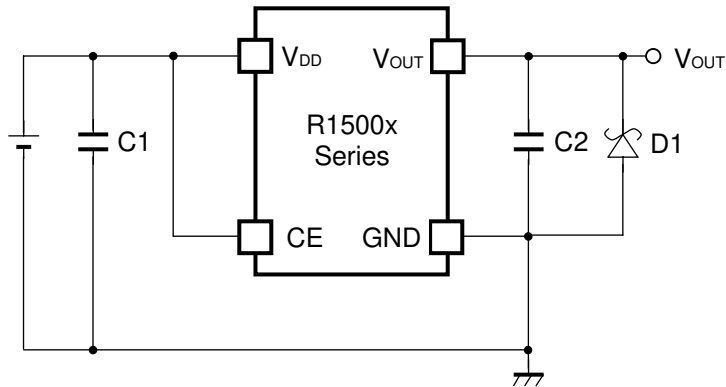
TYPICAL APPLICATION FOR IC CHIP BREAKDOWN PREVENTION

When a sudden surge of electrical current travels along the V_{OUT} pin and GND due to a short-circuit, electrical resonance of a circuit involving an output capacitor (C2) and a short circuit inductor generates a negative voltage and may damage the device or the load devices. Connecting a schottky diode (D1) between the V_{OUT} pin and GND has the effect of preventing damage to them.

PACKAGE INFORMATION

POWER DISSIPATION (SOT-89-5)

Power Dissipation (P_D) depends on conditions of mounting on board. This specification is based on the measurement at the condition below:

Measurement Conditions

	High Wattage Land Pattern	Standard Land Pattern
Environment	Mounting on Board (Wind velocity = 0 m/s)	Mounting on Board (Wind velocity = 0 m/s)
Board Material	Glass cloth epoxy plastic (Double sided)	Glass cloth epoxy plastic (Double sided)
Board Dimensions	30 mm x 30 mm x 1.6 mm	50 mm x 50 mm x 1.6 mm
Copper Ratio	Top side: Approx. 20%, Back side: Approx. 100%	Top side: Approx. 10%, Back side: Approx. 100%
Through-hole	ϕ 0.85 mm x 10 pcs	-

Measurement Result

($T_a = 25^\circ\text{C}$, $T_{j\text{max}} = 150^\circ\text{C}$)

	High Wattage Land Pattern	Standard Land Pattern	Free Air
Power Dissipation	1620 mW	1120 mW	620 mW
Thermal Resistance	77°C/W	111°C/W	200°C/W

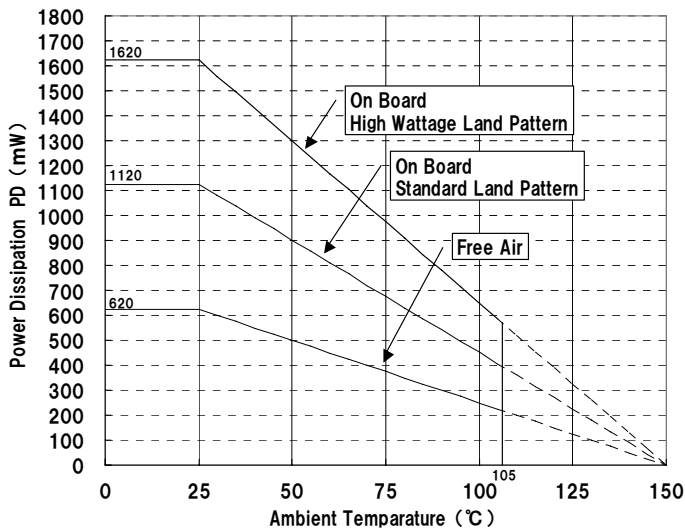

Power Dissipation

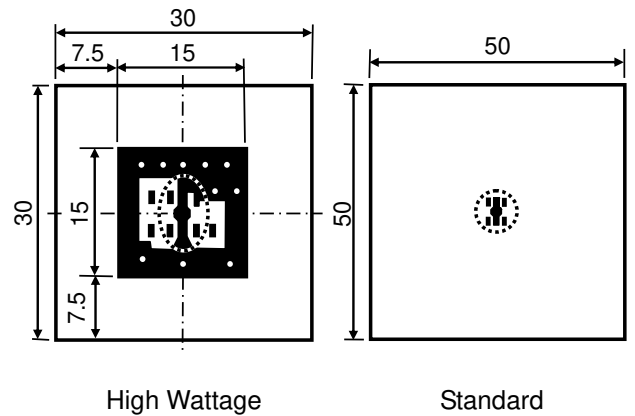

Measurement Board Pattern

 IC Mount Area (Unit: mm)

R1500H

NO.EC-151-140513

PACKAGE DIMENSIONS (SOT-89-5)

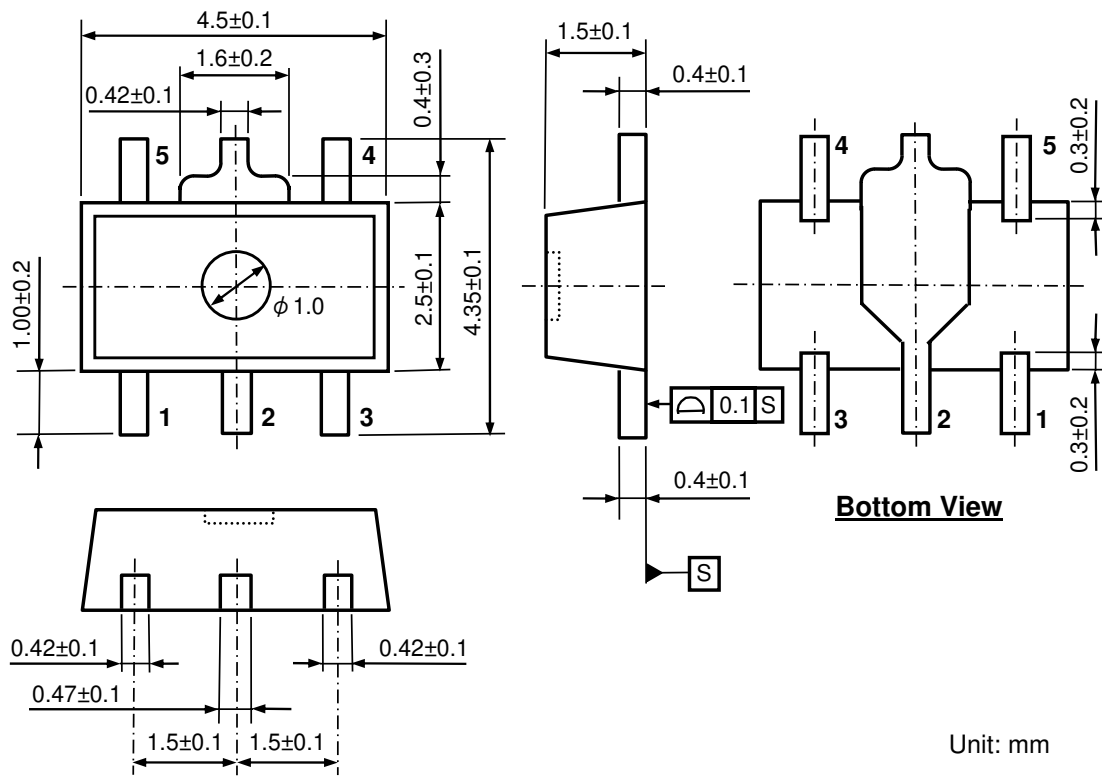

Unit: mm

Package Dimensions (SOT-89-5)

MARK SPECIFICATION (SOT-89-5)

①②③④: Product Code ... **Refer to MARK SPECIFICATION TABLE (SOT-89-5)**

⑤⑥: Lot Number ... Alphanumeric Serial Number

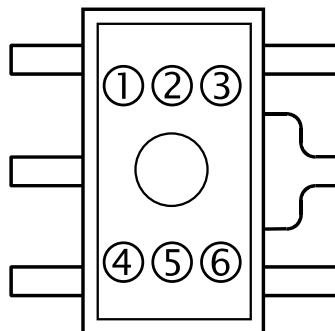

Mark Specification (SOT-89-5)

MARK SPECIFICATION TABLE (SOT-89-5)

Product Name	①②③④	V _{SET}	Product Name	①②③④	V _{SET}	Product Name	①②③④	V _{SET}
R1500H030B	R 0 3 0	3.0 V	R1500H070B	R 0 7 0	7.0 V	R1500H110B	R 1 1 0	11.0 V
R1500H031B	R 0 3 1	3.1 V	R1500H071B	R 0 7 1	7.1 V	R1500H111B	R 1 1 1	11.1 V
R1500H032B	R 0 3 2	3.2 V	R1500H072B	R 0 7 2	7.2 V	R1500H112B	R 1 1 2	11.2 V
R1500H033B	R 0 3 3	3.3 V	R1500H073B	R 0 7 3	7.3 V	R1500H113B	R 1 1 3	11.3 V
R1500H034B	R 0 3 4	3.4 V	R1500H074B	R 0 7 4	7.4 V	R1500H114B	R 1 1 4	11.4 V
R1500H035B	R 0 3 5	3.5 V	R1500H075B	R 0 7 5	7.5 V	R1500H115B	R 1 1 5	11.5 V
R1500H036B	R 0 3 6	3.6 V	R1500H076B	R 0 7 6	7.6 V	R1500H116B	R 1 1 6	11.6 V
R1500H037B	R 0 3 7	3.7 V	R1500H077B	R 0 7 7	7.7 V	R1500H117B	R 1 1 7	11.7 V
R1500H038B	R 0 3 8	3.8 V	R1500H078B	R 0 7 8	7.8 V	R1500H118B	R 1 1 8	11.8 V
R1500H039B	R 0 3 9	3.9 V	R1500H079B	R 0 7 9	7.9 V	R1500H119B	R 1 1 9	11.9 V
R1500H040B	R 0 4 0	4.0 V	R1500H080B	R 0 8 0	8.0 V	R1500H120B	R 1 2 0	12.0 V
R1500H041B	R 0 4 1	4.1 V	R1500H081B	R 0 8 1	8.1 V			
R1500H042B	R 0 4 2	4.2 V	R1500H082B	R 0 8 2	8.2 V			
R1500H043B	R 0 4 3	4.3 V	R1500H083B	R 0 8 3	8.3 V			
R1500H044B	R 0 4 4	4.4 V	R1500H084B	R 0 8 4	8.4 V			
R1500H045B	R 0 4 5	4.5 V	R1500H085B	R 0 8 5	8.5 V			
R1500H046B	R 0 4 6	4.6 V	R1500H086B	R 0 8 6	8.6 V			
R1500H047B	R 0 4 7	4.7 V	R1500H087B	R 0 8 7	8.7 V			
R1500H048B	R 0 4 8	4.8 V	R1500H088B	R 0 8 8	8.8 V			
R1500H049B	R 0 4 9	4.9 V	R1500H089B	R 0 8 9	8.9 V			
R1500H050B	R 0 5 0	5.0 V	R1500H090B	R 0 9 0	9.0 V			
R1500H051B	R 0 5 1	5.1 V	R1500H091B	R 0 9 1	9.1 V			
R1500H052B	R 0 5 2	5.2 V	R1500H092B	R 0 9 2	9.2 V			
R1500H053B	R 0 5 3	5.3 V	R1500H093B	R 0 9 3	9.3 V			
R1500H054B	R 0 5 4	5.4 V	R1500H094B	R 0 9 4	9.4 V			
R1500H055B	R 0 5 5	5.5 V	R1500H095B	R 0 9 5	9.5 V			
R1500H056B	R 0 5 6	5.6 V	R1500H096B	R 0 9 6	9.6 V			
R1500H057B	R 0 5 7	5.7 V	R1500H097B	R 0 9 7	9.7 V			
R1500H058B	R 0 5 8	5.8 V	R1500H098B	R 0 9 8	9.8 V			
R1500H059B	R 0 5 9	5.9 V	R1500H099B	R 0 9 9	9.9 V			
R1500H060B	R 0 6 0	6.0 V	R1500H100B	R 1 0 0	10.0 V			
R1500H061B	R 0 6 1	6.1 V	R1500H101B	R 1 0 1	10.1 V			
R1500H062B	R 0 6 2	6.2 V	R1500H102B	R 1 0 2	10.2 V			
R1500H063B	R 0 6 3	6.3 V	R1500H103B	R 1 0 3	10.3 V			
R1500H064B	R 0 6 4	6.4 V	R1500H104B	R 1 0 4	10.4 V			
R1500H065B	R 0 6 5	6.5 V	R1500H105B	R 1 0 5	10.5 V			
R1500H066B	R 0 6 6	6.6 V	R1500H106B	R 1 0 6	10.6 V			
R1500H067B	R 0 6 7	6.7 V	R1500H107B	R 1 0 7	10.7 V			
R1500H068B	R 0 6 8	6.8 V	R1500H108B	R 1 0 8	10.8 V			
R1500H069B	R 0 6 9	6.9 V	R1500H109B	R 1 0 9	10.9 V			

TEST CIRCUITS

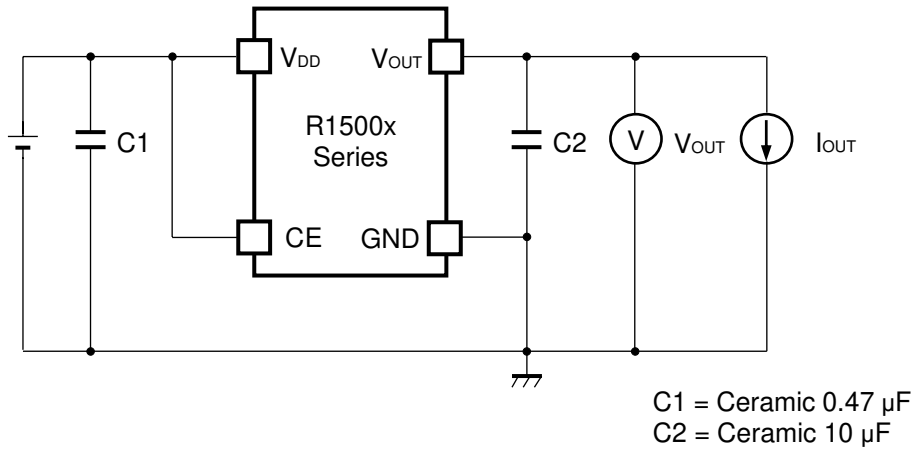

Basic Test Circuit

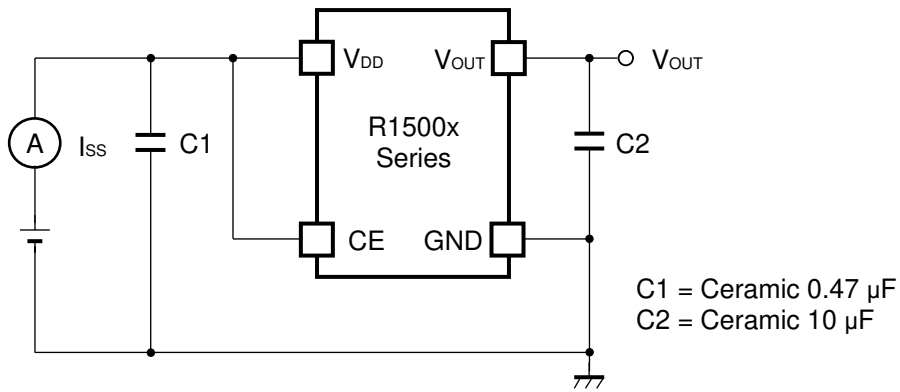

Test Circuit for Supply Current

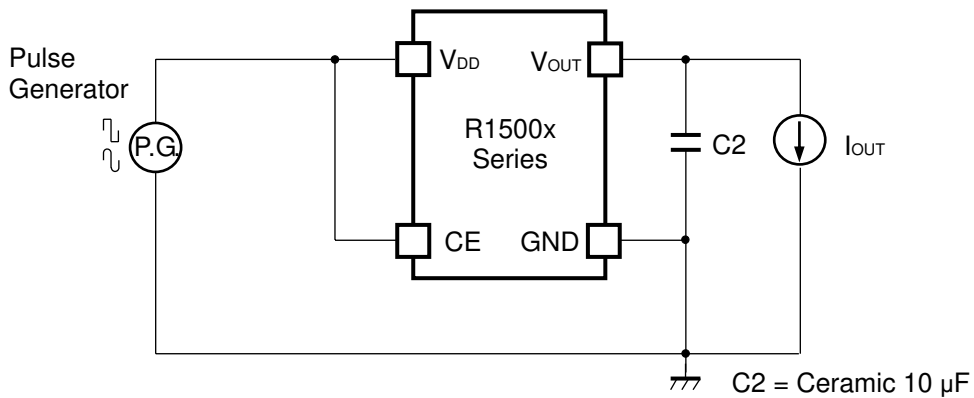

Test Circuit for Ripple Rejection, Input Transient Response

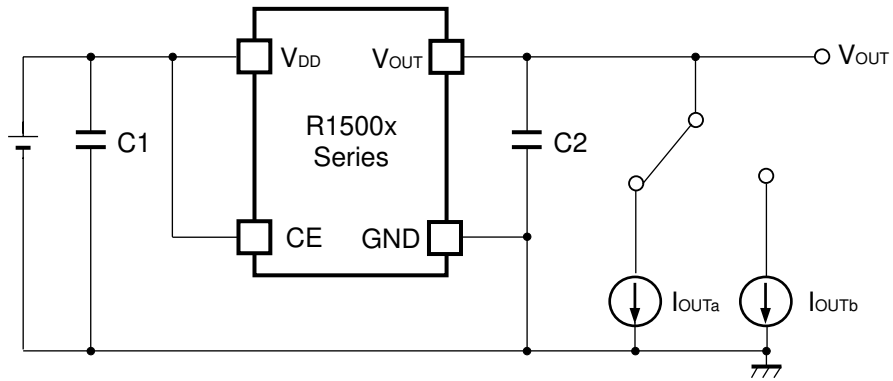

C1 = Ceramic 0.47 μ F
C2 = Ceramic 10 μ F

Test Circuit for Load Transient Response

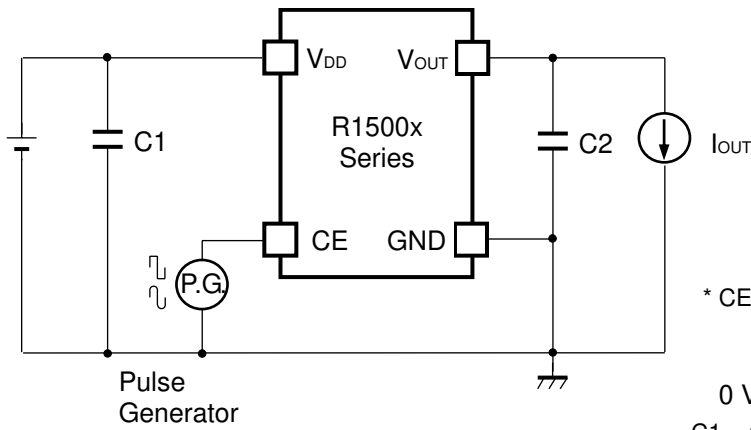

* CE pin Input Waveform

0 V  Set $V_{OUT} + 1.0$ V

C1 = Ceramic 0.47 μ F
C2 = Ceramic 10 μ F

Test Circuit for Turn On Speed with CE pin

TYPICAL CHARACTERISTICS

Note: Typical Characteristics are intended to be used as reference data; they are not guaranteed.

1) Output Voltage vs. Output Current (C1 = Ceramic 0.47 μ F, C2 = Ceramic 10 μ F, Ta = 25°C)

R1500x030B

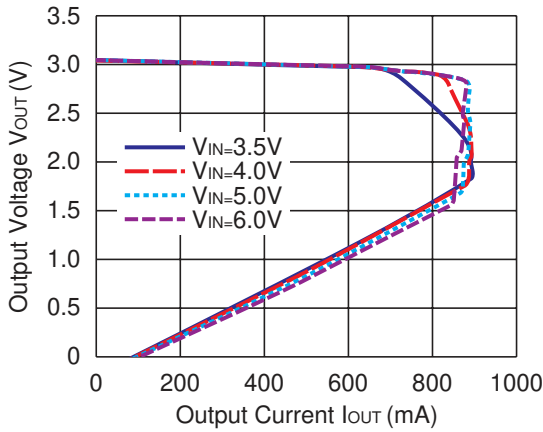

R1500x050B

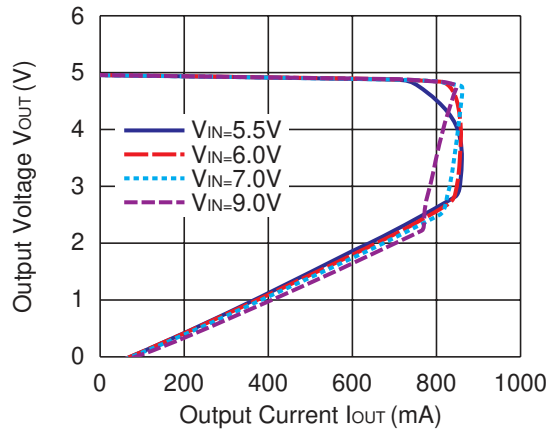

R1500x090B

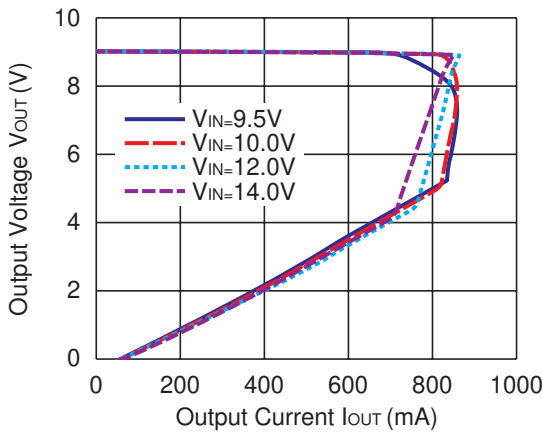

R1500x120B

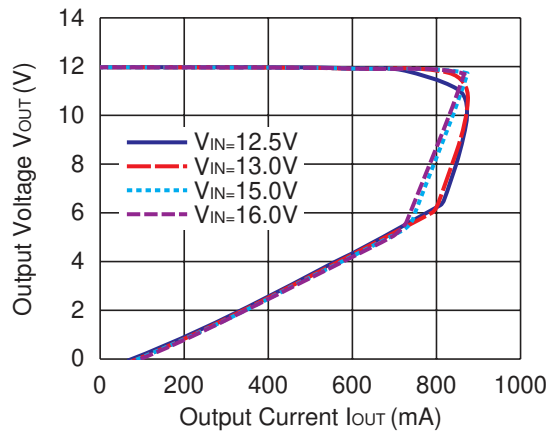

2) Output Voltage vs. Input Voltage (C1 = Ceramic 0.47 μ F, C2 = Ceramic 10 μ F, Ta = 25°C)

R1500x030B

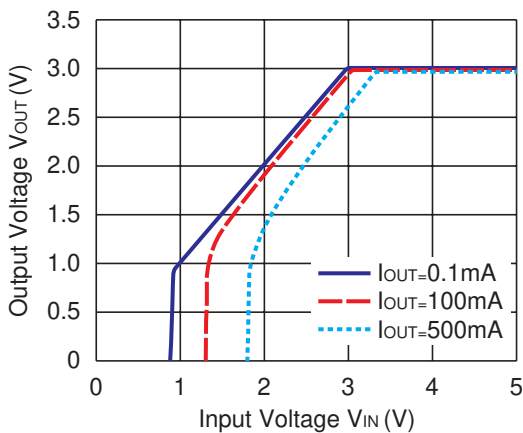

R1500x050B

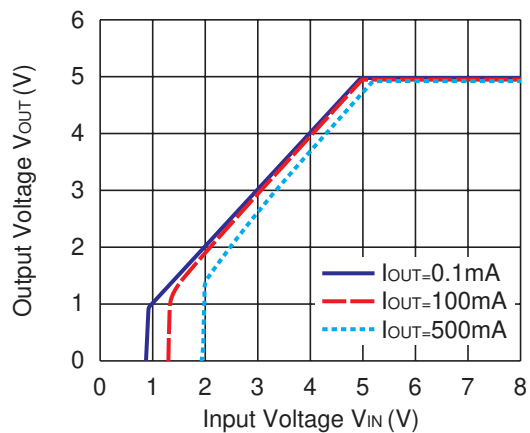

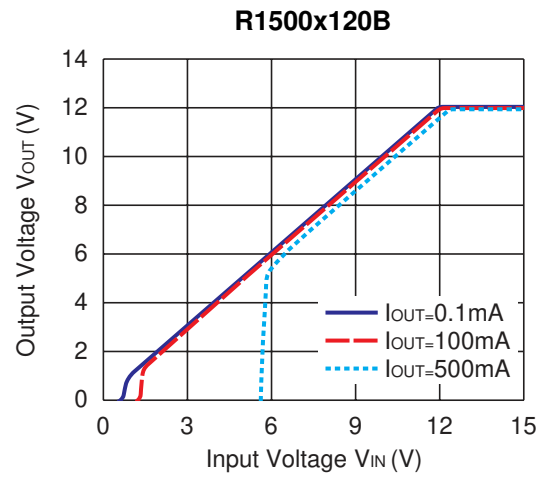
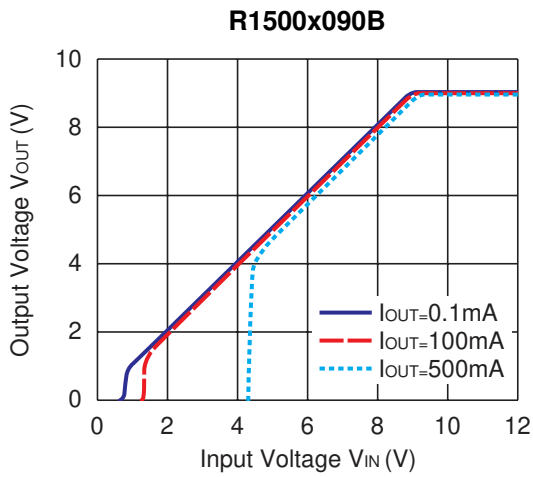

3) Supply Current vs. Input Voltage (C1 = Ceramic 0.47 μ F, C2 = Ceramic 10 μ F, Ta = 25°C)

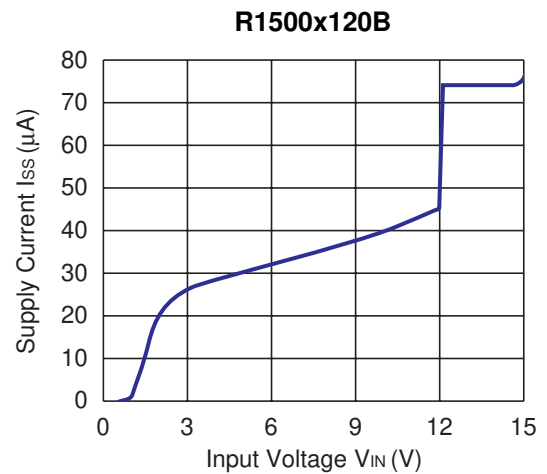
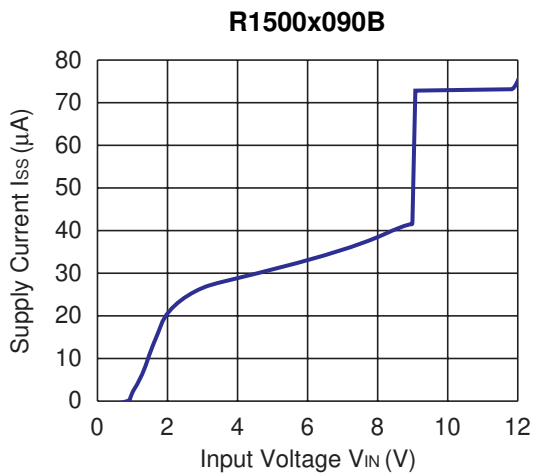
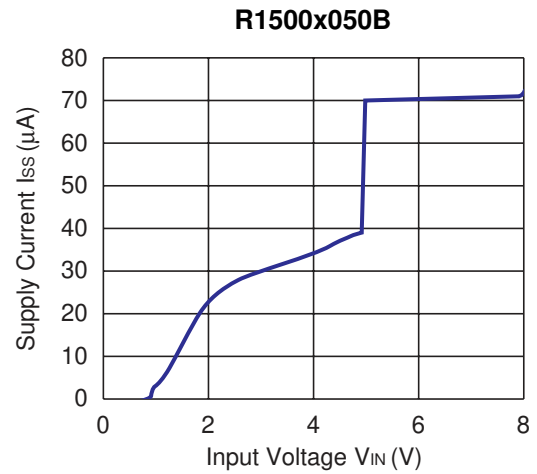
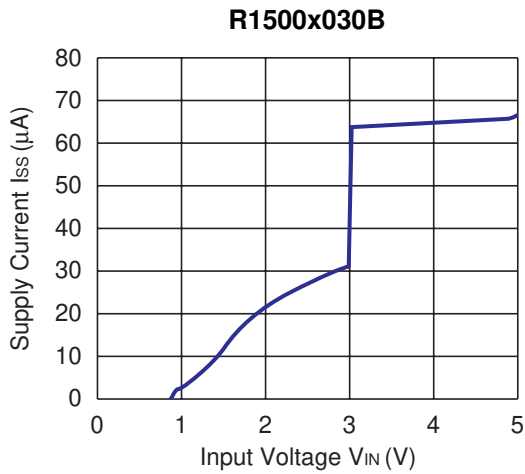

R1500H

NO.EC-151-140513

4) Output Voltage vs. Temperature (C1 = Ceramic 0.47 μ F, C2 = Ceramic 10 μ F, I_{OUT} = 100 mA)

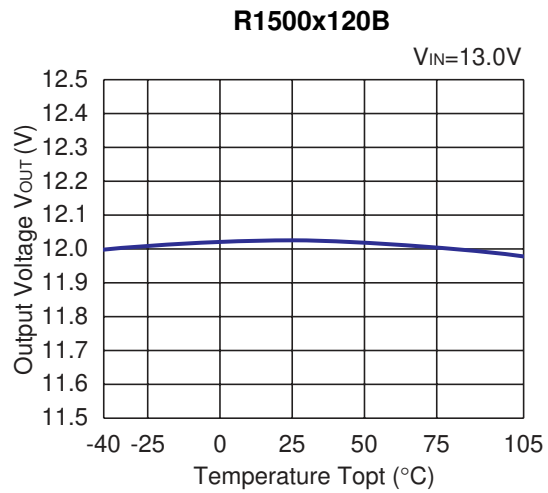
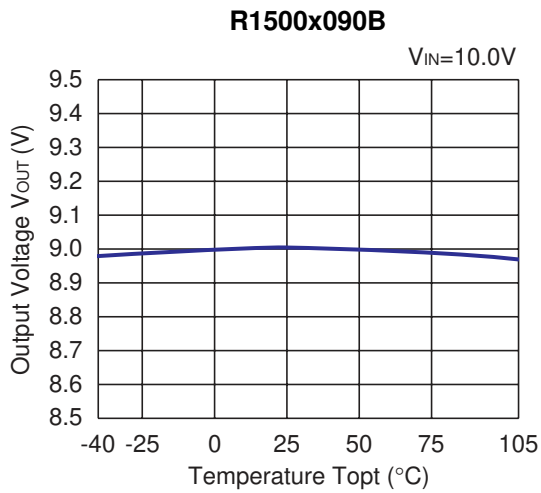
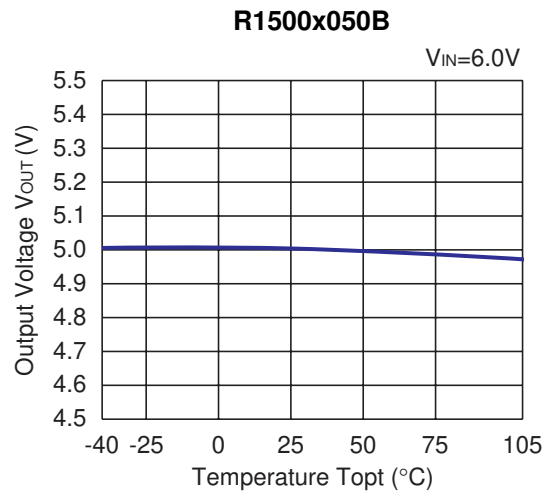
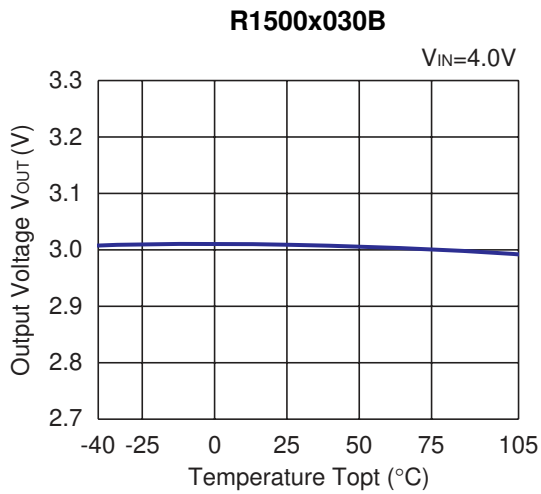

5) Supply Current vs. Temperature (C1 = Ceramic 0.47 μ F, C2 = Ceramic 10 μ F, I_{OUT} = 0 mA)

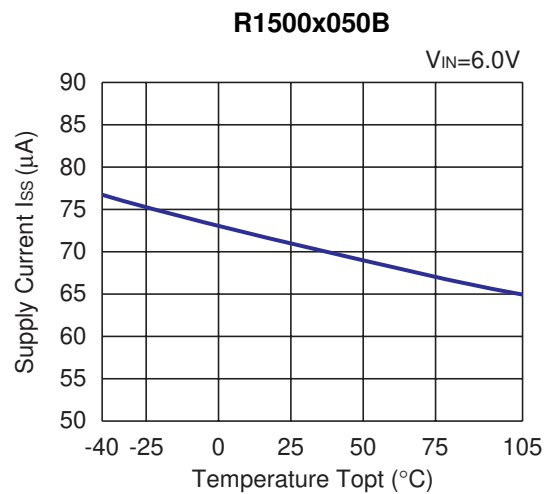
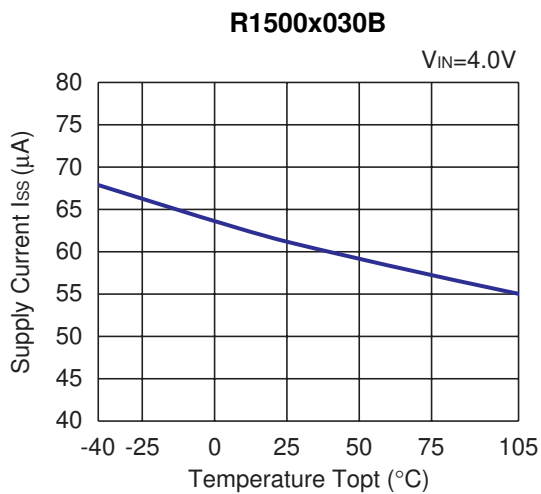

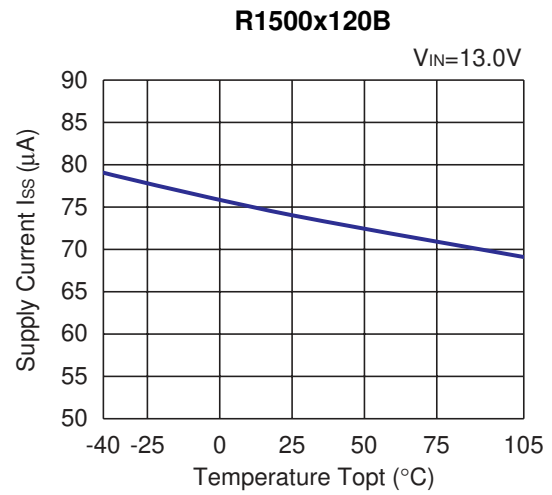
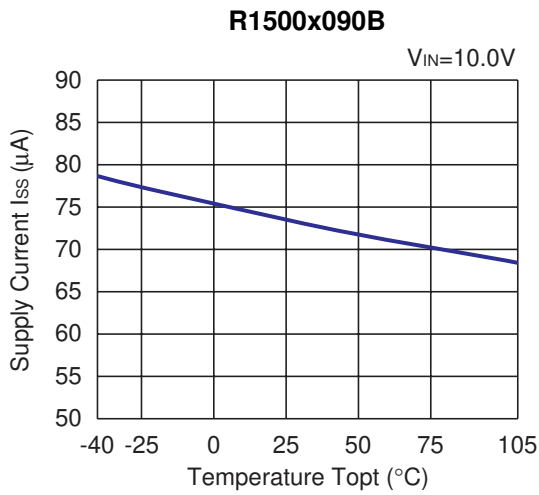

6) Dropout Voltage vs. Output Current (C1 = Ceramic 0.47 µF, C2 = Ceramic 10 µF)

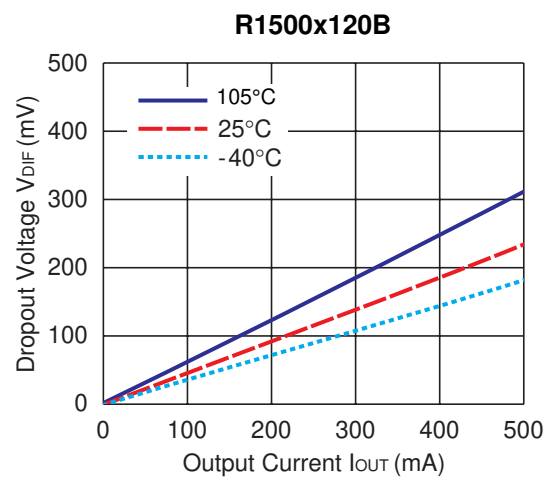
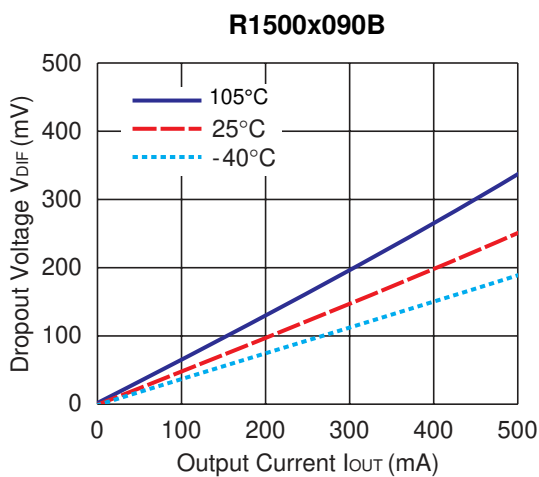
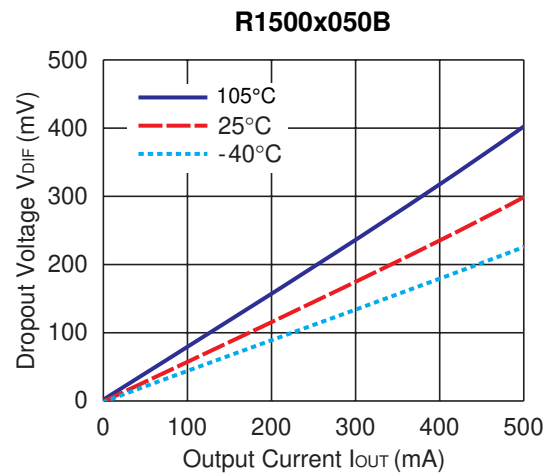
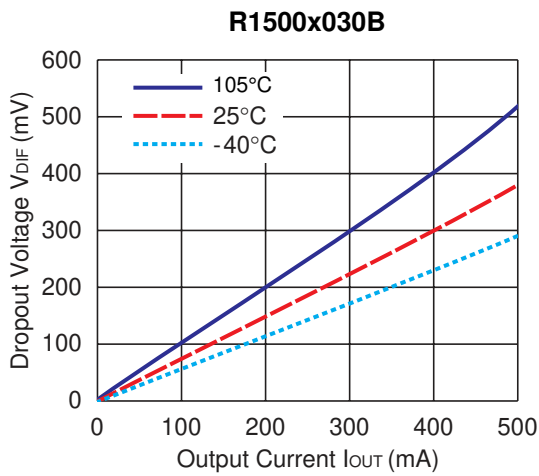

R1500H

NO.EC-151-140513

7) Dropout Voltage vs. Set Output Voltage (C1 = Ceramic 0.47 μ F, C2 = Ceramic 10 μ F, Ta = 25°C)

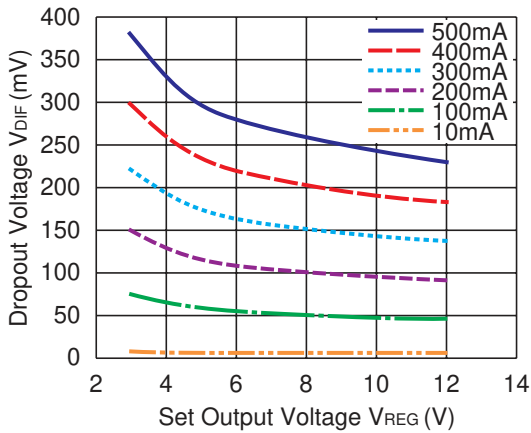

8) Ripple Rejection vs. Input Bias Voltage (C1 = none, C2 = Ceramic 10 μ F, $I_{OUT} = 100$ mA, Ta = 25°C)

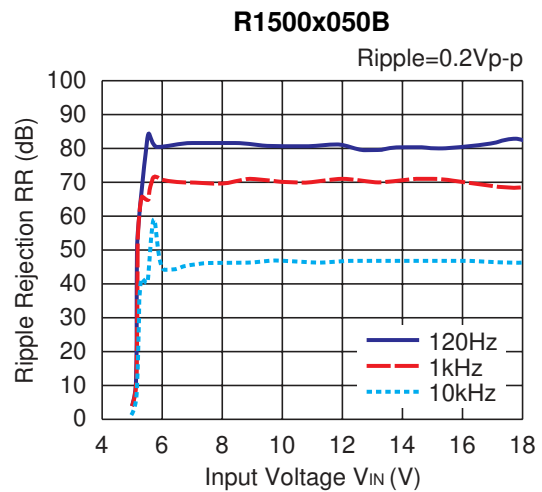
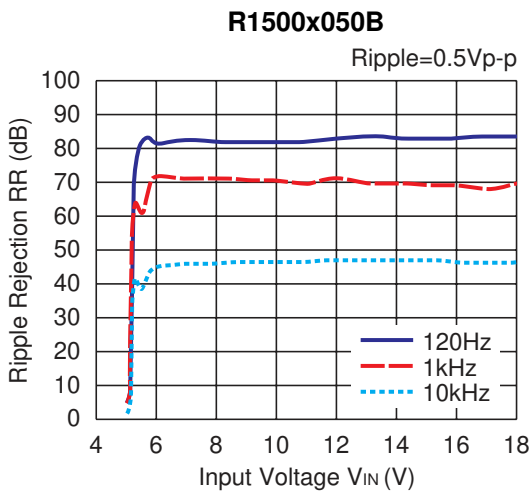

9) Ripple Rejection vs. Frequency (C1 = none, C2 = Ceramic 10 μ F, Ripple = 0.5 V_{p-p})

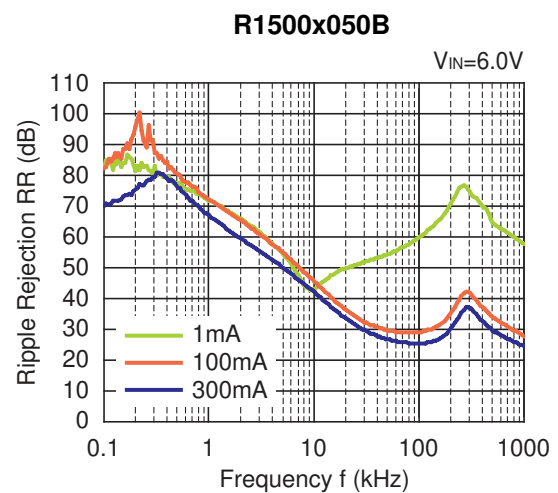
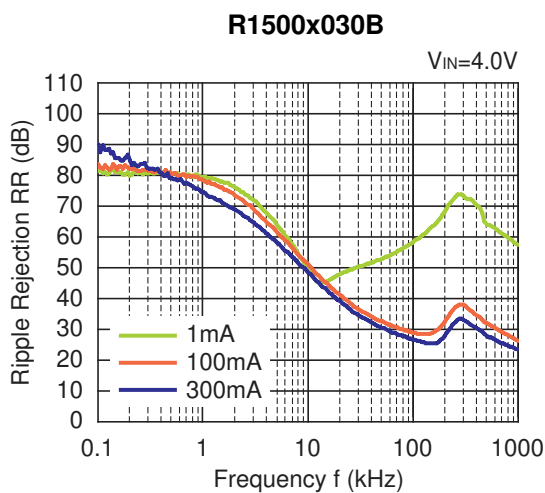

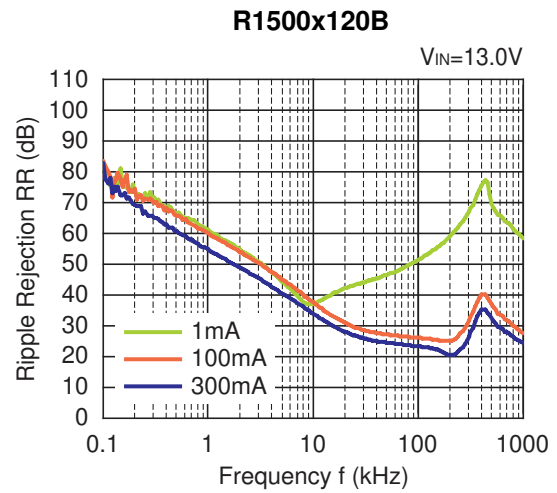
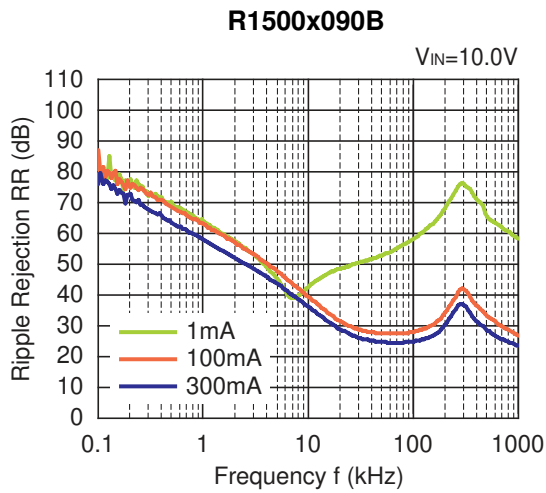

10) Input Transient Response (C1 = none, C2 = Ceramic 10 μF , $I_{OUT} = 100\text{ mA}$, $t_r = t_f = 10\ \mu s$, $T_a = 25^\circ C$)

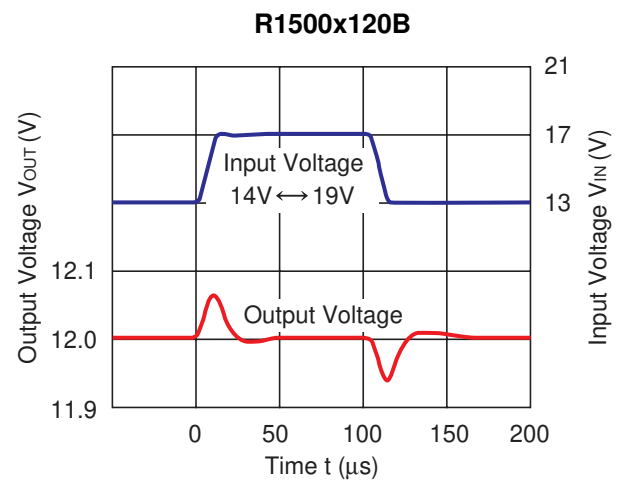
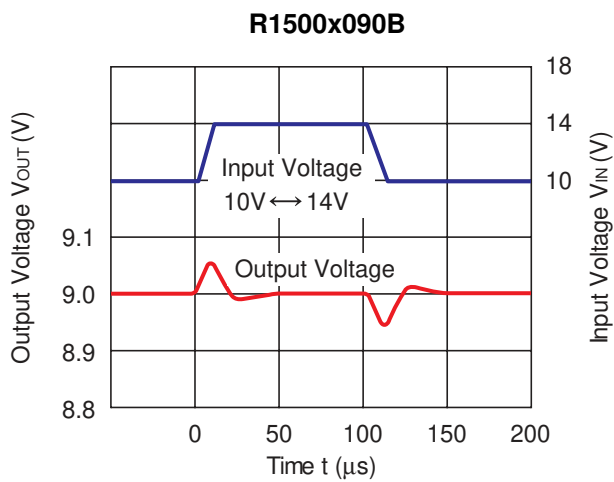
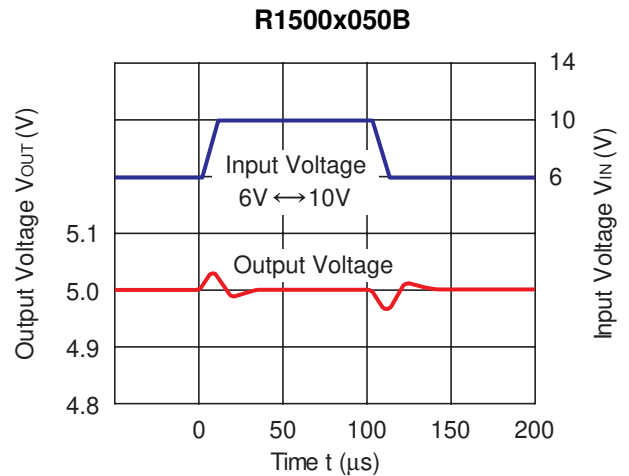
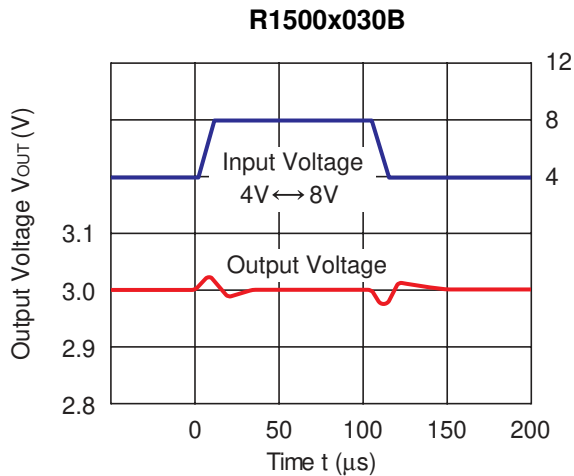

11) Load Transient Response (C1 = Ceramic 0.47 μ F, C2 = Ceramic 10 μ F, $t_r = t_f = 0.5 \mu$ s, $T_a = 25^\circ$ C)

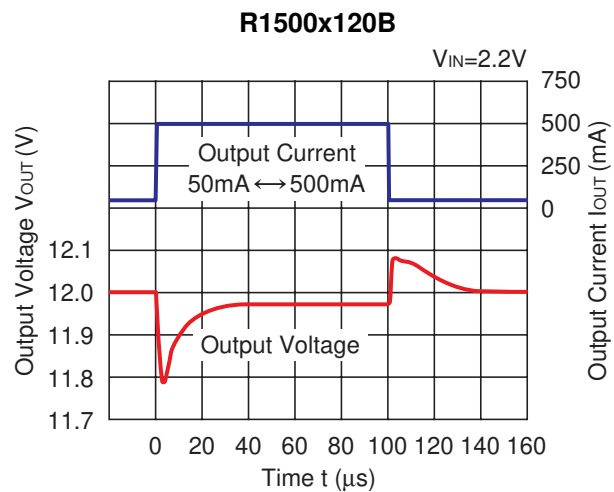
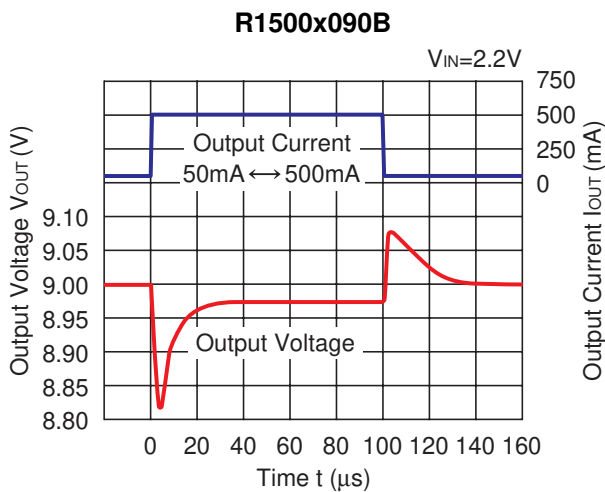
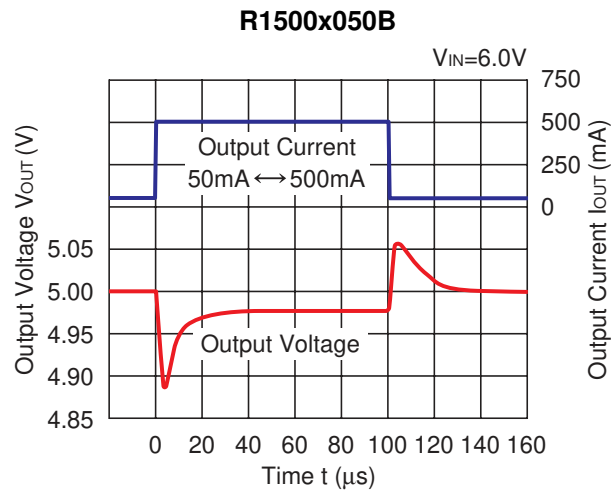
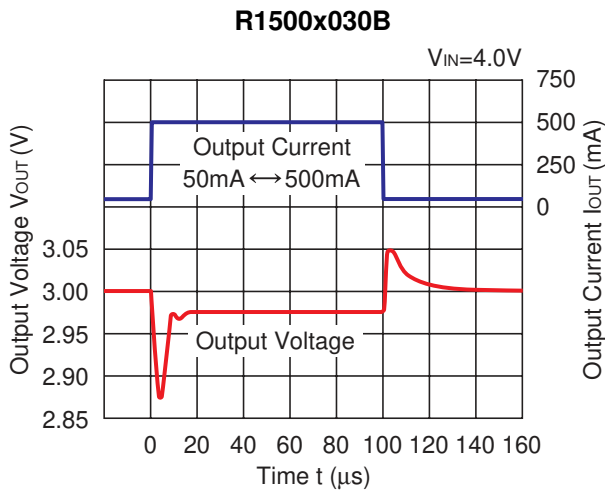

12) Turn On Speed with CE pin (C1 = Ceramic 0.47 μ F, C2 = Ceramic 10 μ F, $T_a = 25^\circ$ C)

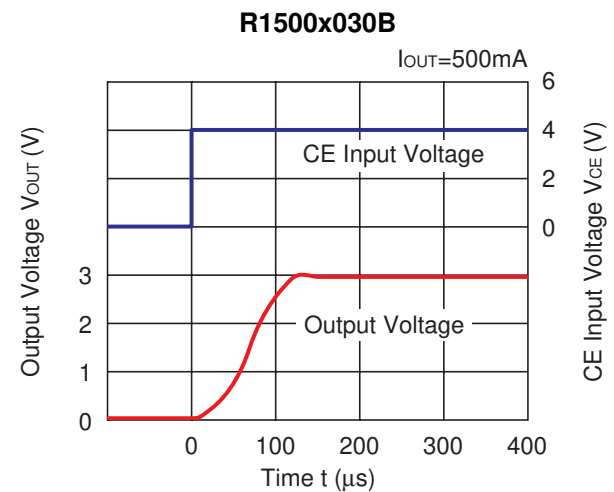
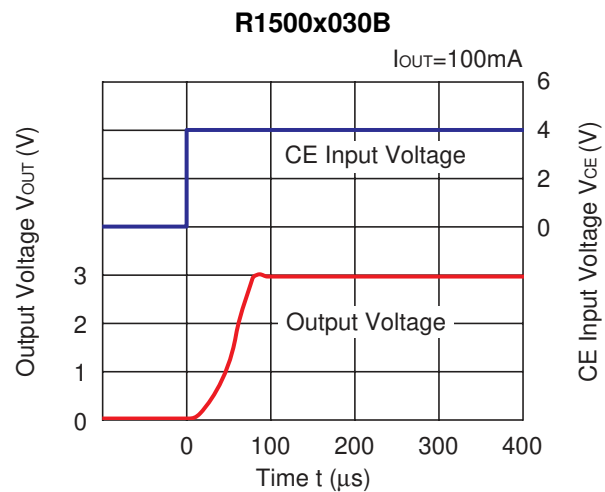

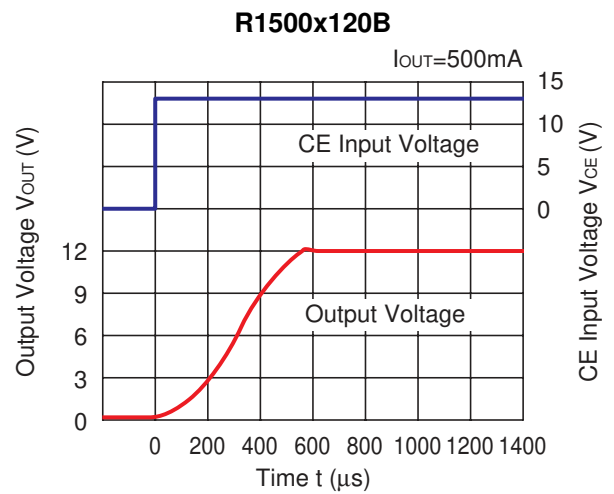
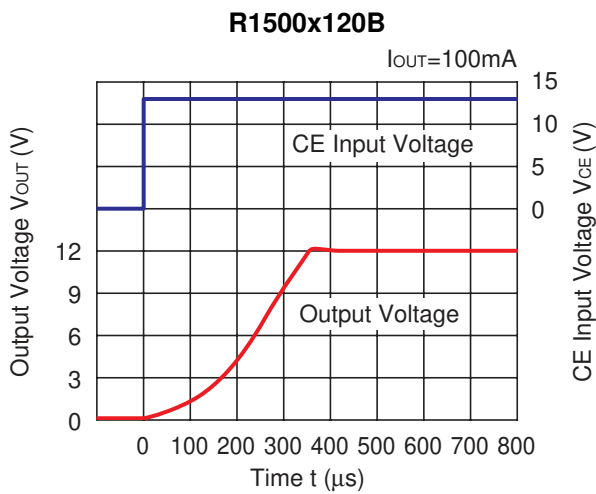
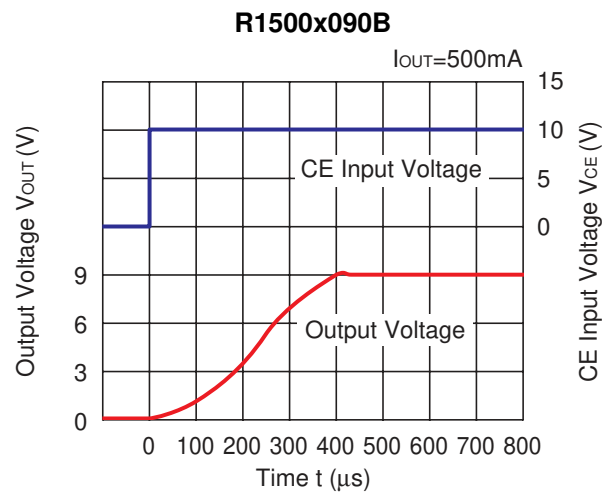
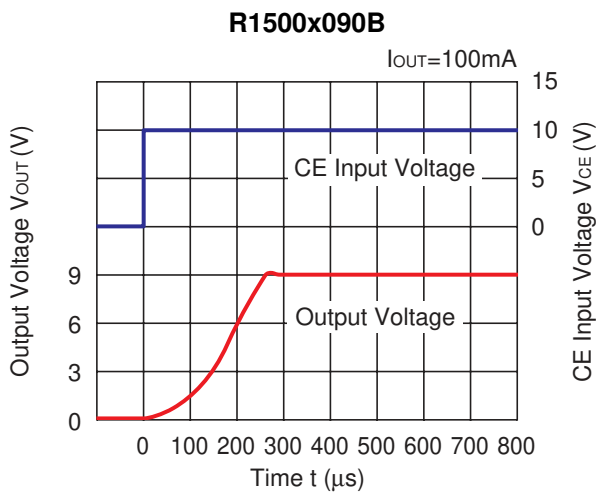
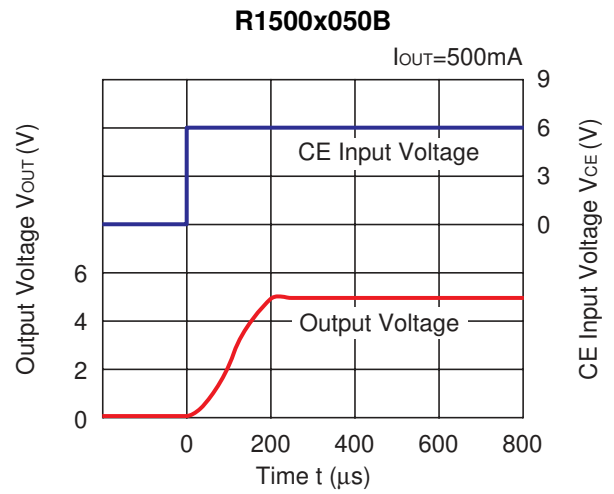
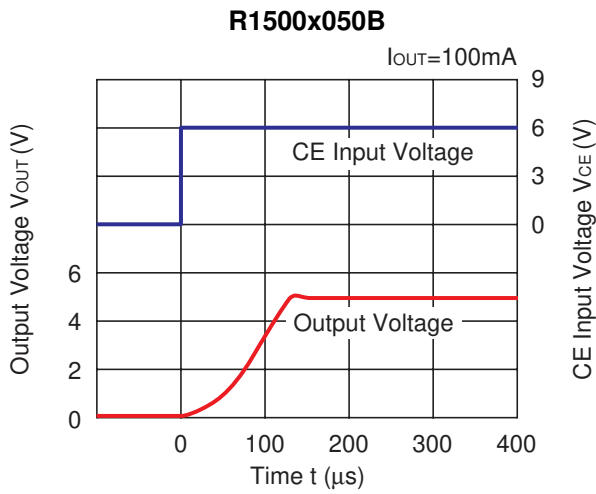

R1500H

NO.EC-151-140513

13) Turn Off Speed with CE (C1 = Ceramic 0.47 μ F, C2 = Ceramic 10 μ F, I_{out} = 500 mA, T_a = 25°C)

R1500x030B

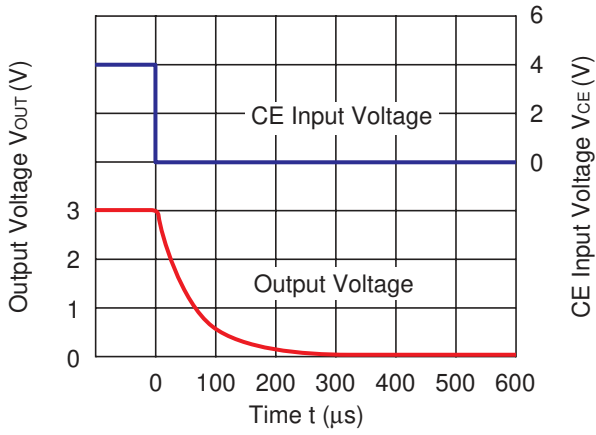

R1500x050B

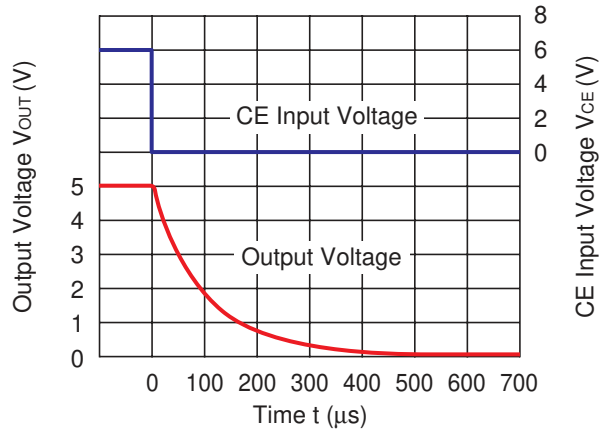

R1500x090B

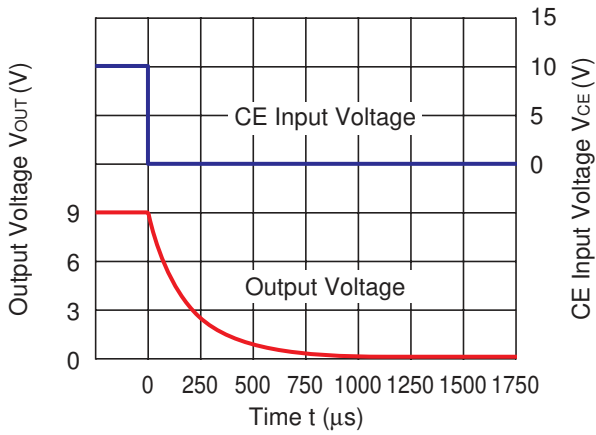

R1500x120B

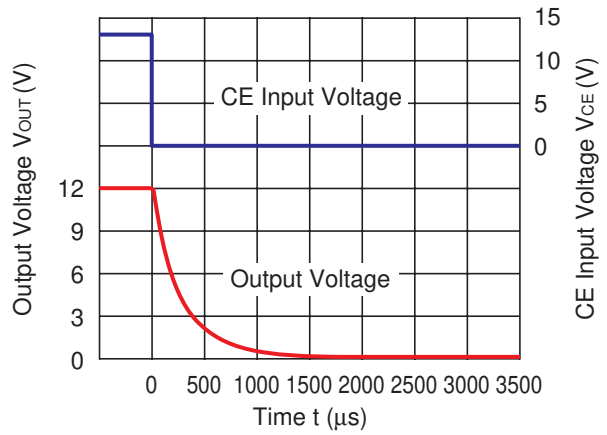

ESR vs. OUTPUT CURRENT

The relations between I_{OUT} (Output Current) and ESR of an output capacitor are shown below.

The conditions when the white noise level is under the specified certain level are marked as the hatched area in the graph.

Measurement conditions

Input Voltage : $V_{OUT} + 1\text{ V}$

Frequency Band : 10 Hz to 1 MHz

Temperature : -40°C to 105°C

R1500x030B

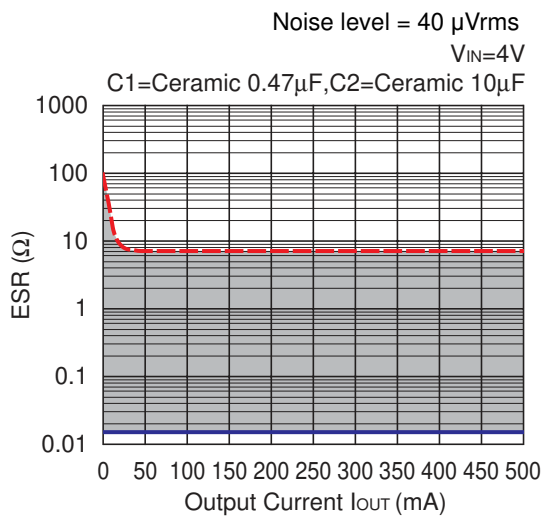

R1500x030B

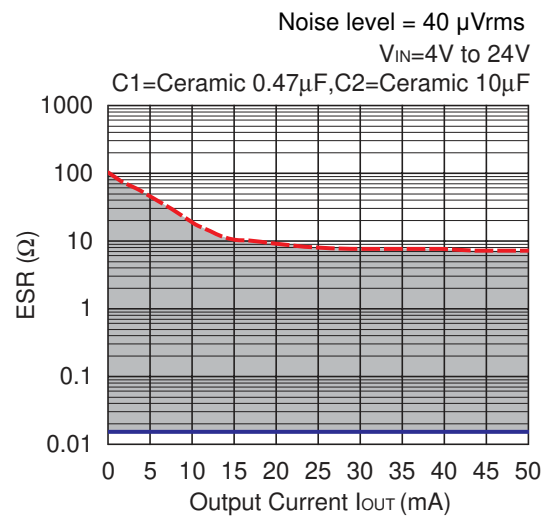

R1500x050B

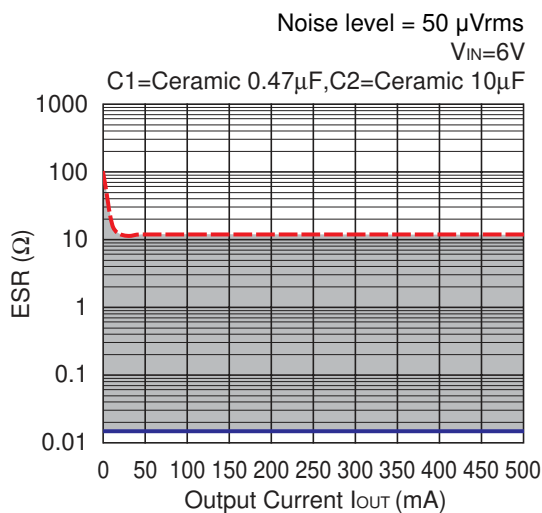

R1500x050B

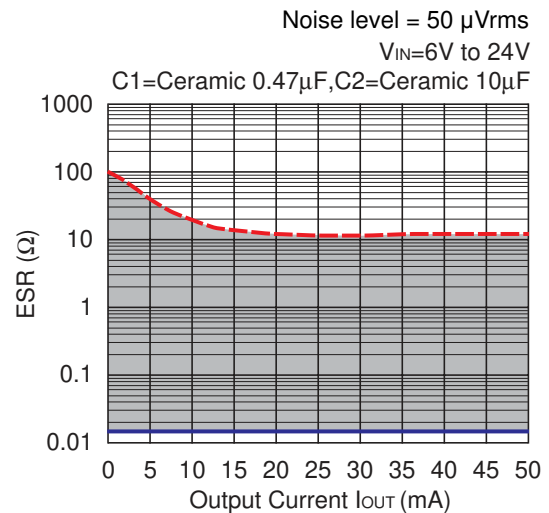

R1500H

NO.EC-151-140513

R1500x090B

Noise level = 120 μ Vrms
 $V_{IN}=10V$

C1=Ceramic 0.47 μ F,C2=Ceramic 10 μ F

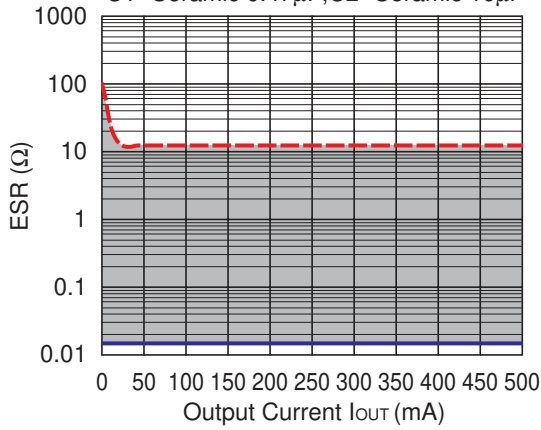

R1500x090B

Noise level = 120 μ Vrms
 $V_{IN}=10V$ to 24V

C1=Ceramic 0.47 μ F,C2=Ceramic 10 μ F

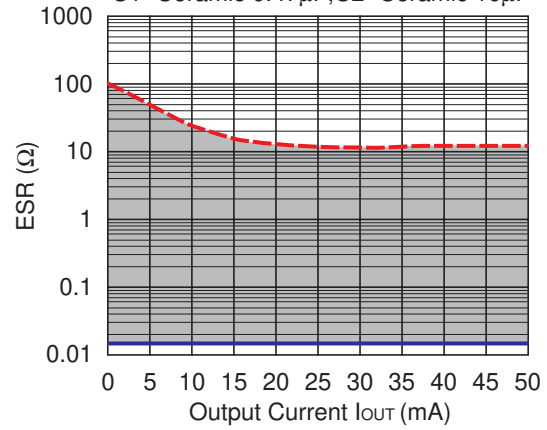

R1500x120B

Noise level = 140 μ Vrms
 $V_{IN}=13V$

C1=Ceramic 0.47 μ F,C2=Ceramic 10 μ F

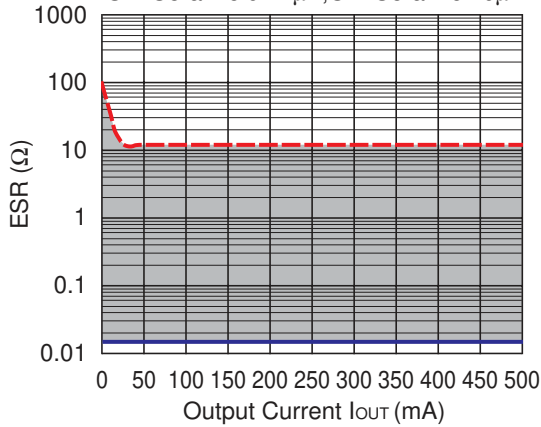

R1500x120B

Noise level = 140 μ Vrms
 $V_{IN}=13V$ to 24V

C1=Ceramic 0.47 μ F,C2=Ceramic 10 μ F

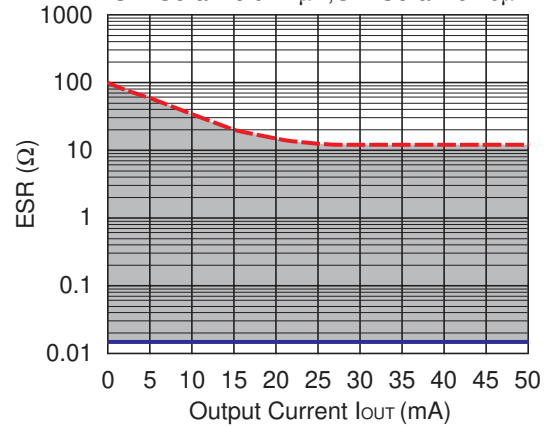



1. The products and the product specifications described in this document are subject to change or discontinuation of production without notice for reasons such as improvement. Therefore, before deciding to use the products, please refer to our sales representatives for the latest information thereon.
2. The materials in this document may not be copied or otherwise reproduced in whole or in part without prior written consent of our company.
3. Please be sure to take any necessary formalities under relevant laws or regulations before exporting or otherwise taking out of your country the products or the technical information described herein.
4. The technical information described in this document shows typical characteristics of and example application circuits for the products. The release of such information is not to be construed as a warranty of or a grant of license under our company's or any third party's intellectual property rights or any other rights.
5. The products in this document are designed for automotive applications. However, when using the products for automotive applications, please make sure to contact our sales representative in advance due to confirming the quality level.
6. We are making our continuous effort to improve the quality and reliability of our products, but semiconductor products are likely to fail with certain probability. In order to prevent any injury to persons or damages to property resulting from such failure, customers should be careful enough to incorporate safety measures in their design, such as redundancy feature, fire containment feature and fail-safe feature. We do not assume any liability or responsibility for any loss or damage arising from misuse or inappropriate use of the products.
7. Anti-radiation design is not implemented in the products described in this document.
8. The X-ray exposure can influence functions and characteristics of the products. Confirm the product functions and characteristics in the evaluation stage.
9. WLCSP products should be used in light shielded environments. The light exposure can influence functions and characteristics of the products under operation or storage.
10. There can be variation in the marking when different AOI (Automated Optical Inspection) equipment is used. In the case of recognizing the marking characteristic with AOI, please contact our sales or our distributor before attempting to use AOI.
11. Please contact our sales representatives should you have any questions or comments concerning the products or the technical information.



Nisshinbo Micro Devices Inc.

Official website

<https://www.nisshinbo-microdevices.co.jp/en/>

Purchase information

<https://www.nisshinbo-microdevices.co.jp/en/buy/>

