

LOC		DIST		REVISIONS					
ES		00		P	LTN	DESCRIPTION	DATE	DWN	APVD
		4				PRELIMINARY	04MAY2014	HW	MC
		5				ADD 2170539-5	04MAY2014	HW	MC
		A				ADD SHEET 6 2170539-6	17SEP2015	RG	SH

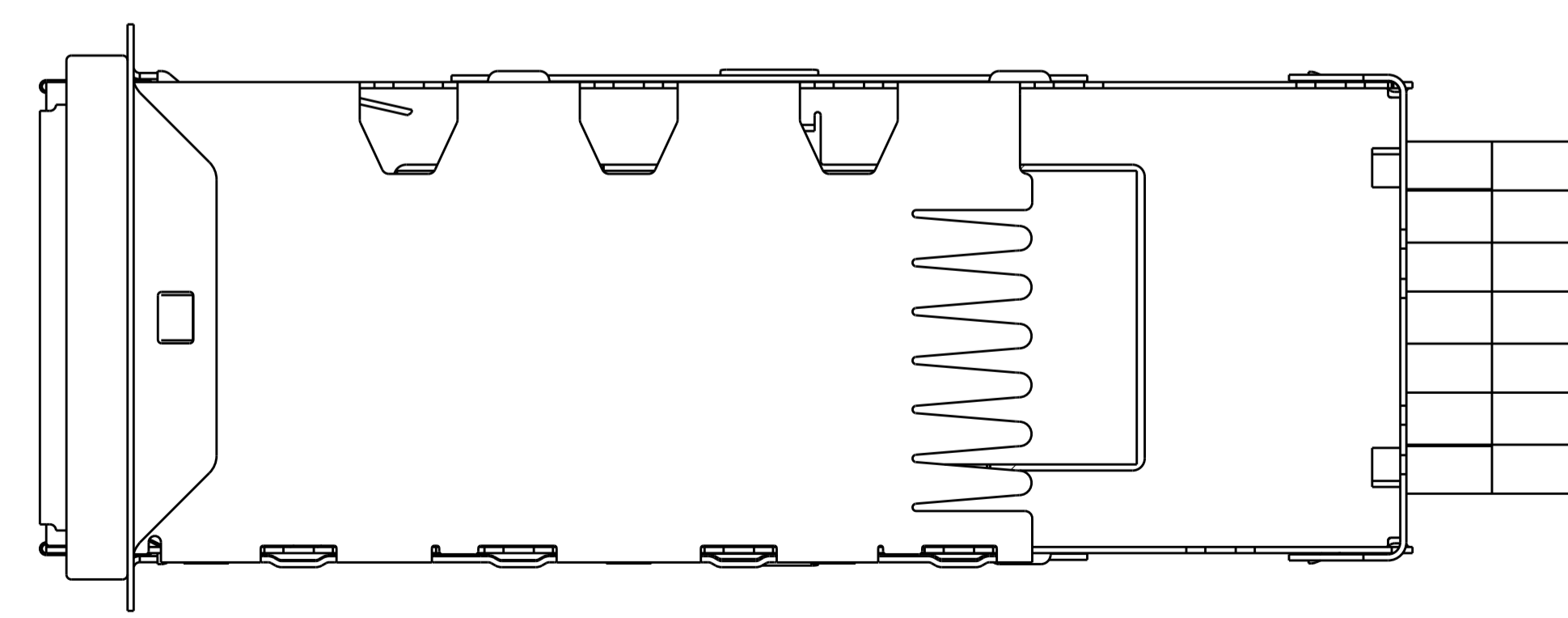
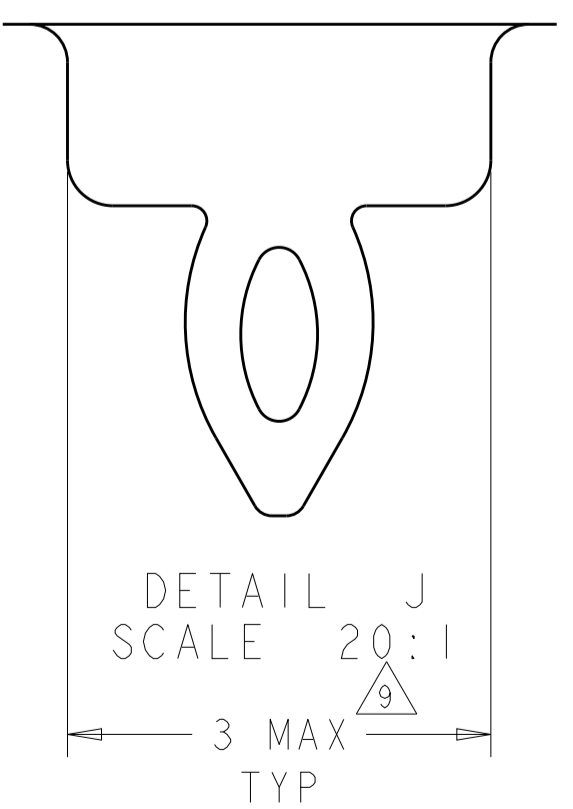
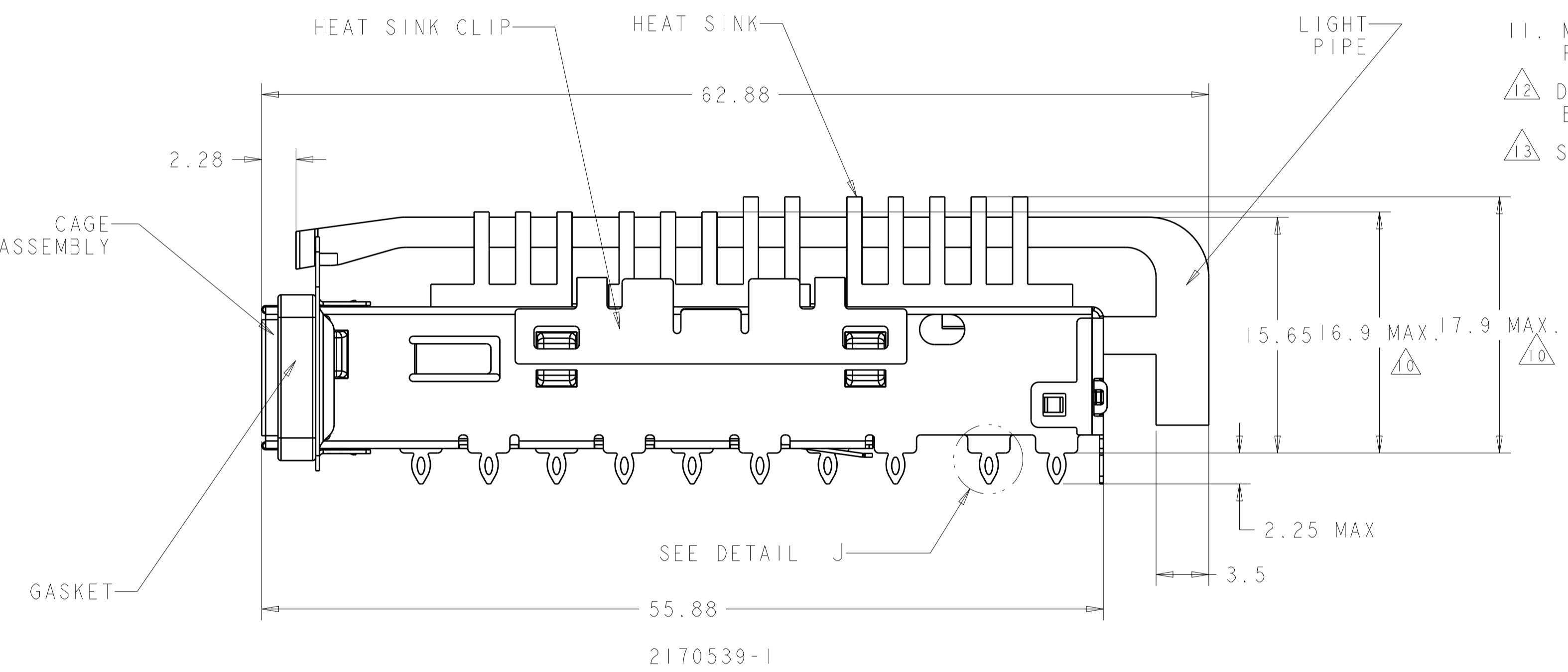
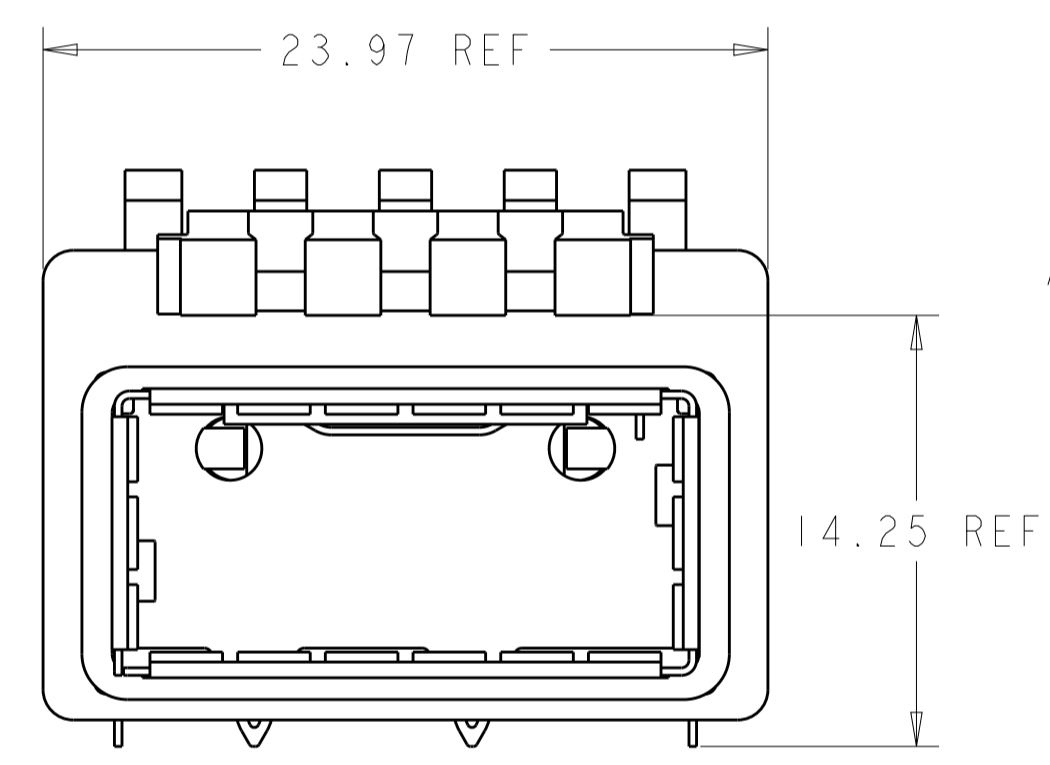
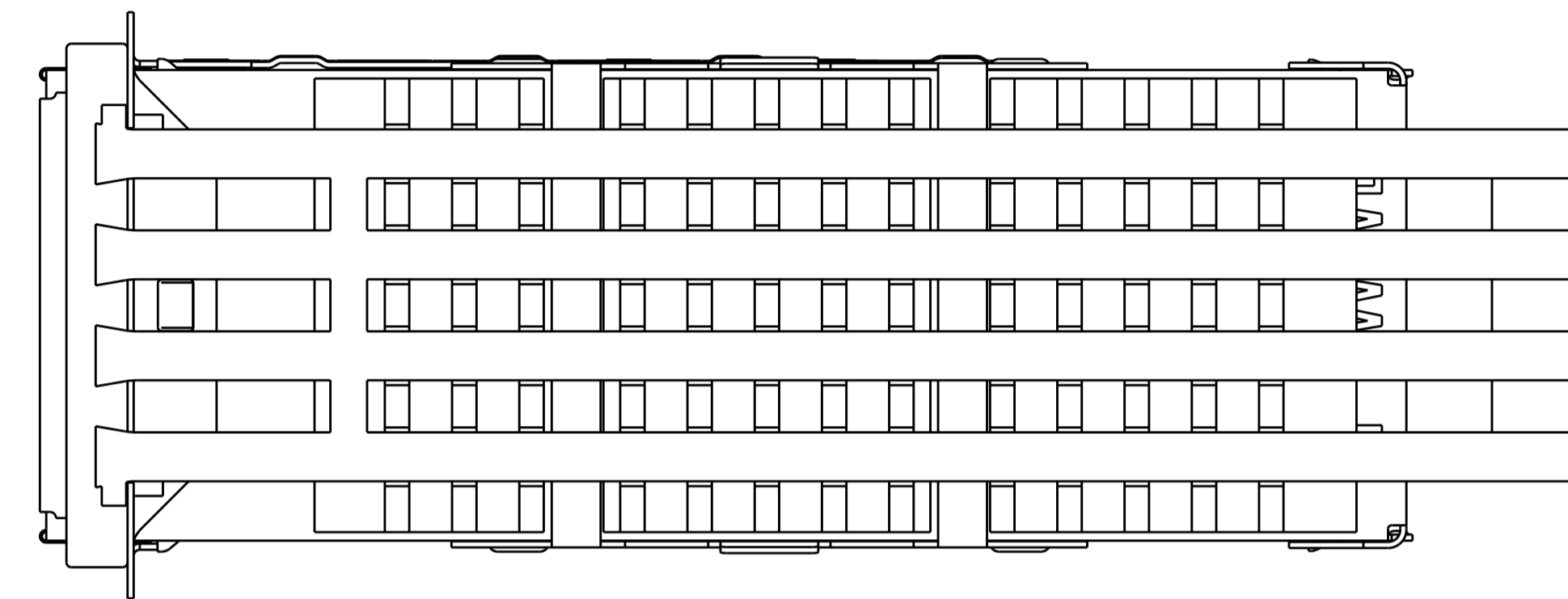
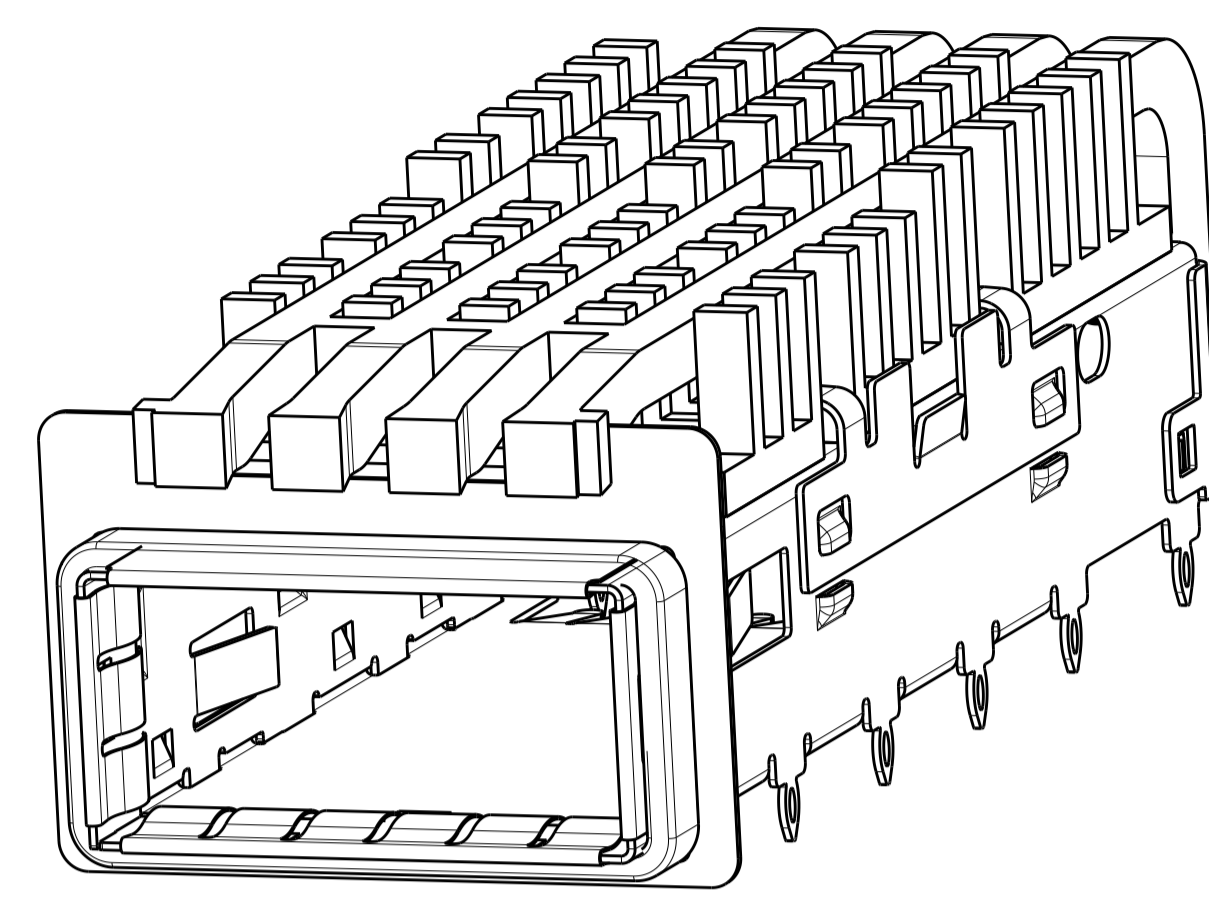

- 1. CAGE MATERIAL: NICKEL SILVER, 0.25 THICK
 HEAT SINK MATERIAL: ALUMINUM
 HEAT SINK CLIP MATERIAL: STAINLESS STEEL
 LIGHT PIPE MATERIAL: CLEAR POLYCARBONATE, UL-94V-0 RATED.
 EMI SPRING MATERIAL: COPPER ALLOY
- 2. MINIMUM PITCH DIMENSION.
- 3. MATES WITH QSFP MSA COMPATIBLE TRANSCEIVER.
- 4. REFERENCE APPLICATION SPEC 114-13217 FOR RECOMMENDED DRILL HOLE DIAMETER AND PLATING THICKNESS.
- 5. DATUMS AND BASIC DIMENSIONS ESTABLISHED BY CUSTOMER.
- 6. MINIMUM PC BOARD THICKNESS:
 SINGLE SIDED = 1.45mm (shown, pg. 4)
- 7. HEAT SINK, CLIP, AND LIGHT PIPE SHIPPED ASSEMBLED TO CAGE ASSEMBLY. CAGE ASSEMBLY MAY BE PRESSED INTO THE PCB AS SHIPPED.
- 8. DATUM [-A-] IS TOP SURFACE OF HOST BOARD.
- 9. SURFACE TRACES PERMITTED WITHIN THIS AREA EXCEPT WHERE CAGE STANDOFFS, SHOWN IN DETAIL J, CONTACT PC BOARD.
- 10. DIMENSION APPLIES WITH MODULE INSTALLED IN THE CAGE TO TOP OF HEAT SINK.
- 11. MAXIMUM HEIGHT OF CUSTOMER SUPPLIED LED OFF PC BOARD: 1.70mm.
- 12. DATE CODE (YYWWD) MARKED ON TOP OF CAGE AND CONCEALED BY HEAT SINK APPLIES TO CAGE ASSEMBLY ONLY.
- 13. SPRING FINISH: MATT TIN 2µm MIN, NON-PLATED EDGES PERMISSIBLE.

SAN HEAT SINK WITH ONE PIN HEIGHT, HEAT SINK CLIP HORN SHAPE LP & SOLID GASKET	2170539-5
ONLY SOLID GASKET	2170539-4
SAN HEAT SINK WITH TWO PIN HEIGHT, HEAT SINK CLIP NRMAL LP & HOLLOW GASKET	2170539-3
ONLY HOLLOW GASKET	2170539-2
SAN HEAT SINK WITH TWO PIN HEIGHT, HEAT SINK CLIP HORN SHAPE LP & SOLID GASKET	2170539-1
DESCRIPTION	PART NO

THIS DRAWING IS A CONTROLLED DOCUMENT.		DWN	TIM XUE	14MAY2013	STE TE Connectivity
DIMENSIONS:		CHK	JASON YANG	14MAY2013	
TOLERANCES UNLESS OTHERWISE SPECIFIED:		APVD	ALEY CAI	14MAY2013	
mm		NAME		CAGE ASSEMBLY, QSFP+, W/ HEAT SINK, EMI GASKET AND LIGHT PIPE	
0 PLC ±0.5		PRODUCT SPEC		108-2286	
1 PLC ±0.13		APPLICATION SPEC		114-13217	
2 PLC ±0.013		SIZE		A100779	
3 PLC ±0.001		CAGE CODE		C=2170539	
4 PLC ±0.0001		RESTRICTED TO			
ANGLES ±0.0001		WEIGHT			
FINISH		CUSTOMER DRAWING		SCALE 4:1 SHEET 1 OF 6 REV A	

LOC	DIST	REV	DATE	BY	APPV
		1			

REVISIONS		DATE	BY	APPV
1	SEE SHEET 1			

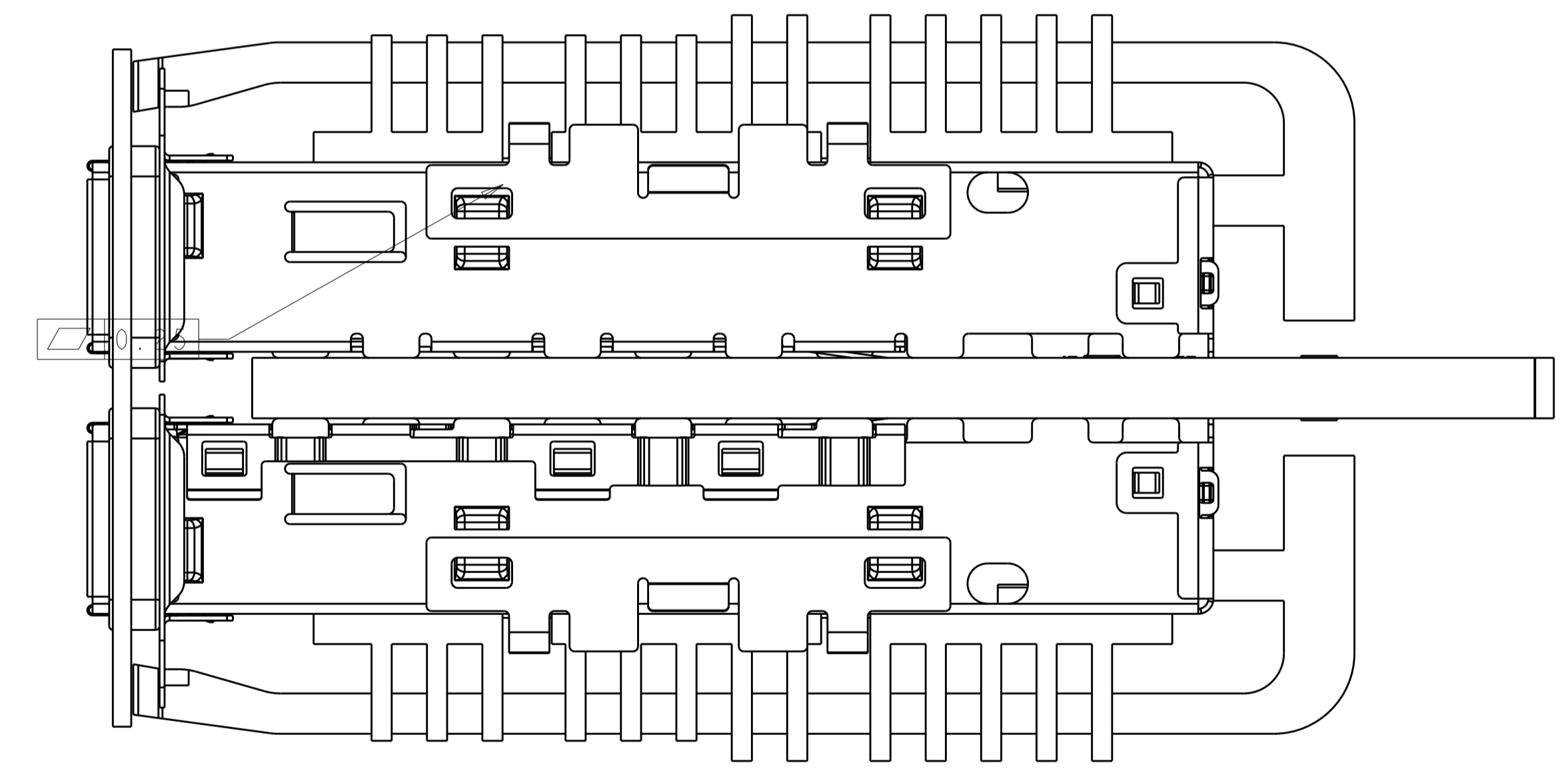
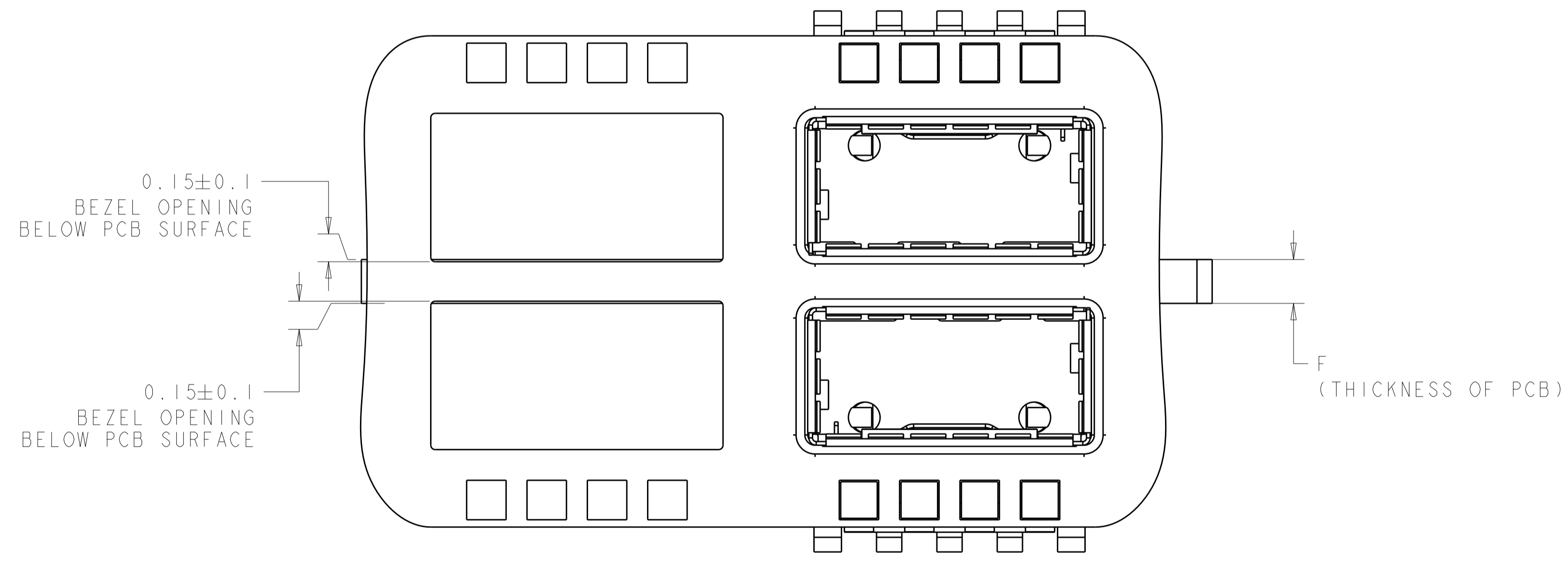
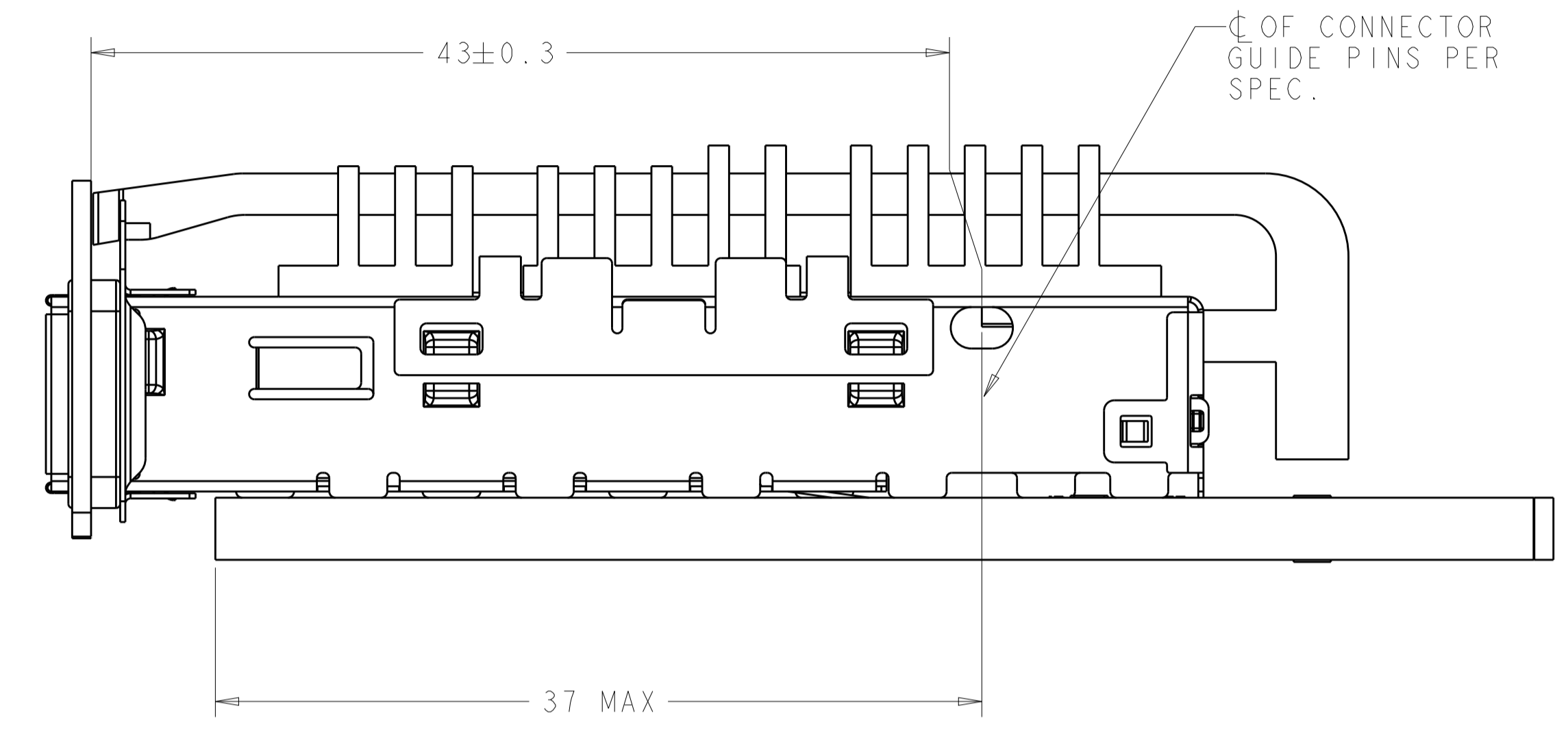
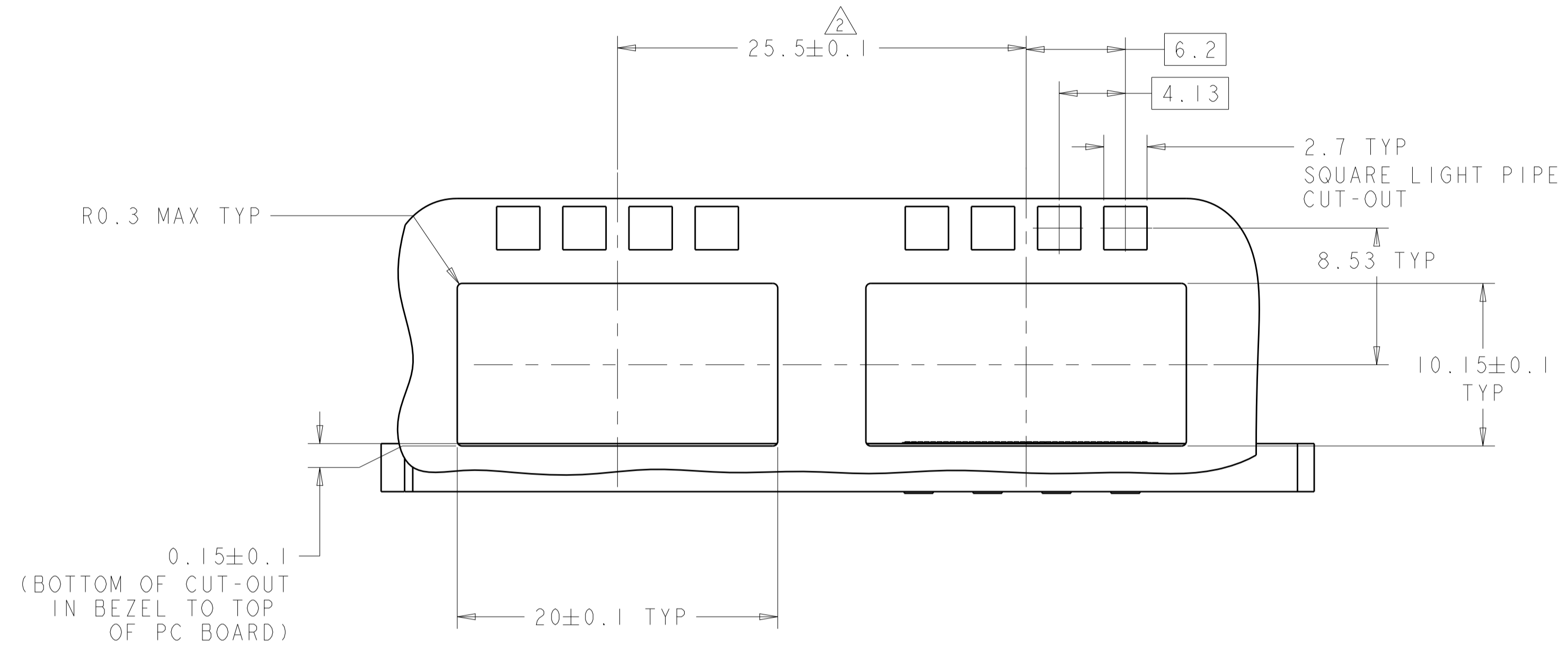

SCALE 4:1

THIS DRAWING IS A CONTROLLED DOCUMENT.		DWN: TIM XUE 14MAY2013 CHK: JASON YANG 14MAY2013 APVD: AILEY CAI 14MAY2013	
DIMENSIONS: mm 	TOLERANCES UNLESS OTHERWISE SPECIFIED: 0 PLC ± 1 PLC ±0.5 2 PLC ±0.13 3 PLC ±0.013 4 PLC ±0.001 ANGLES ±0.0001	NAME: CAGE ASSEMBLY, QSFP+, W/ HEAT SINK, EMI GASKET AND LIGHT PIPE PRODUCT SPEC: 108-2286 APPLICATION SPEC: 114-13217 WEIGHT: - Customer Drawing	

LOC	DIST	REV	DATE	BY	APPV
		1			

REVISIONS					
REV	DATE	DESCRIPTION	BY	APPV	DATE
-	-	SEE SHEET 1	-	-	-

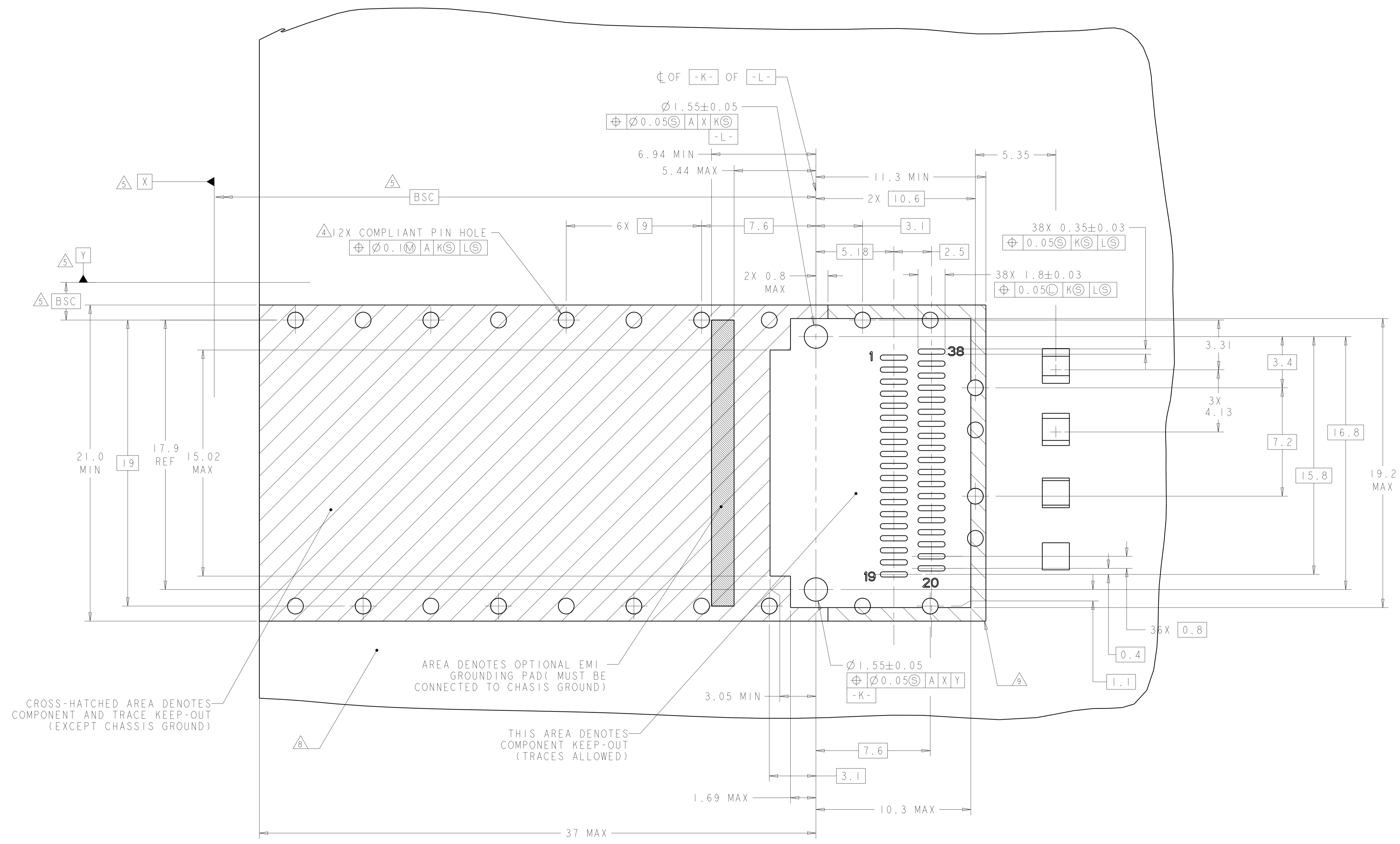

RECOMENDED PC BOARD LAYOUT
 SCALE 8:1

THIS DRAWING IS A CONTROLLED DOCUMENT.		DWN TIM XUE 14MAY2013 CHN JASON YANG 14MAY2013 APVD AILEY CAI 14MAY2013	TE Connectivity NAME CAGE ASSEMBLY, QSPF+, W/ HEAT SINK, EMI GASKET AND LIGHT PIPE
DIMENSIONS: mm 	TOLERANCES UNLESS OTHERWISE SPECIFIED: 0 PLC ± 0.5 1 PLC ± 0.13 2 PLC ± 0.13 3 PLC ± 0.013 4 PLC ± 0.001 ANGLES ± 0.001	PRODUCT SPEC 108-2286 APPLICATION SPEC 114-13217 WEIGHT - Customer Drawing	

THIS DRAWING IS UNPUBLISHED. RELEASED FOR PUBLICATION 2011
 © COPYRIGHT 2011 TE Connectivity ALL RIGHTS RESERVED.

LOC	DIST	REVISIONS					
		P.	LTN	DESCRIPTION	DATE	DWN	APVD
		-		SEE SHEET 1	-	-	-

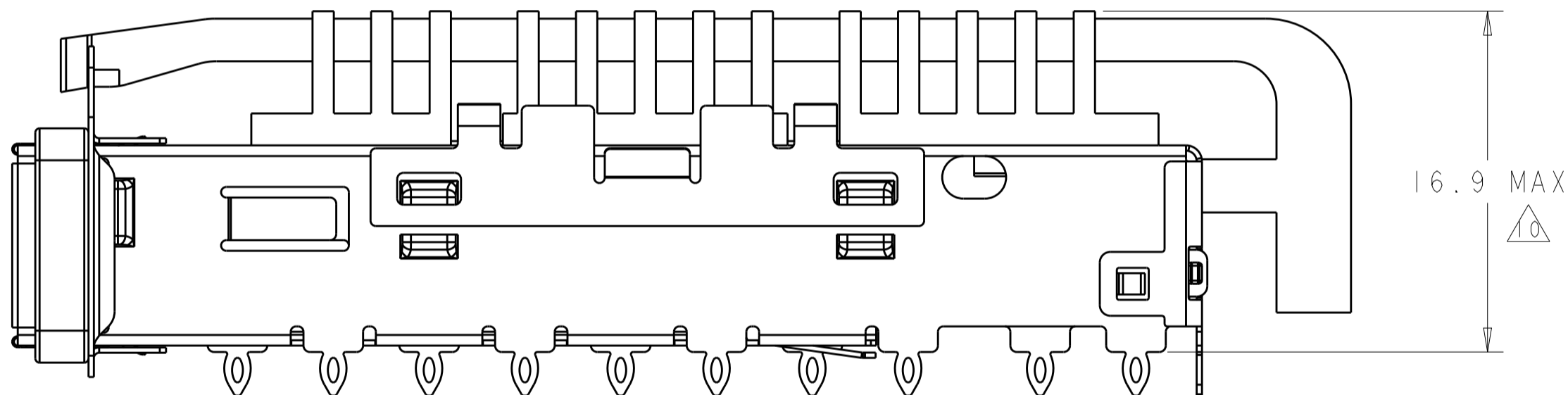

SCALE 4:1
 2170539-5
 EXCEPT INDICATED DIMENSION
 OTHER DIMENSIONS ARE SAME AS 2170539-1

THIS DRAWING IS A CONTROLLED DOCUMENT.		DWN	TIM XUE	14MAY2013	
		CHK	JASON YANG	14MAY2013	
		APVD	ALEY CAI	14MAY2013	
DIMENSIONS:		TOLERANCES UNLESS OTHERWISE SPECIFIED:		NAME	
mm	0 PLC ±0.5	108-2286		CAGE ASSEMBLY, QSFP+, W/ HEAT SINK, EMI GASKET AND LIGHT PIPE	
	2 PLC ±0.13	APPLICATION SPEC		SIZE CAGE CODE DRAWING NO	
	3 PLC ±0.013	114-13217		A100779C=2170539	
	4 PLC ±0.0001	WEIGHT		RESTRICTED TO	
	ANGLES ±0.0001	Customer Drawing		-	
FINISH		SCALE 4:1		SHEET 4 OF 6	
				REV A	

LOC	DIST	REVISIONS			
P.	LTN	DESCRIPTION	DATE	DWN	APVD
-	-	SEE SHEET 1	-	-	-

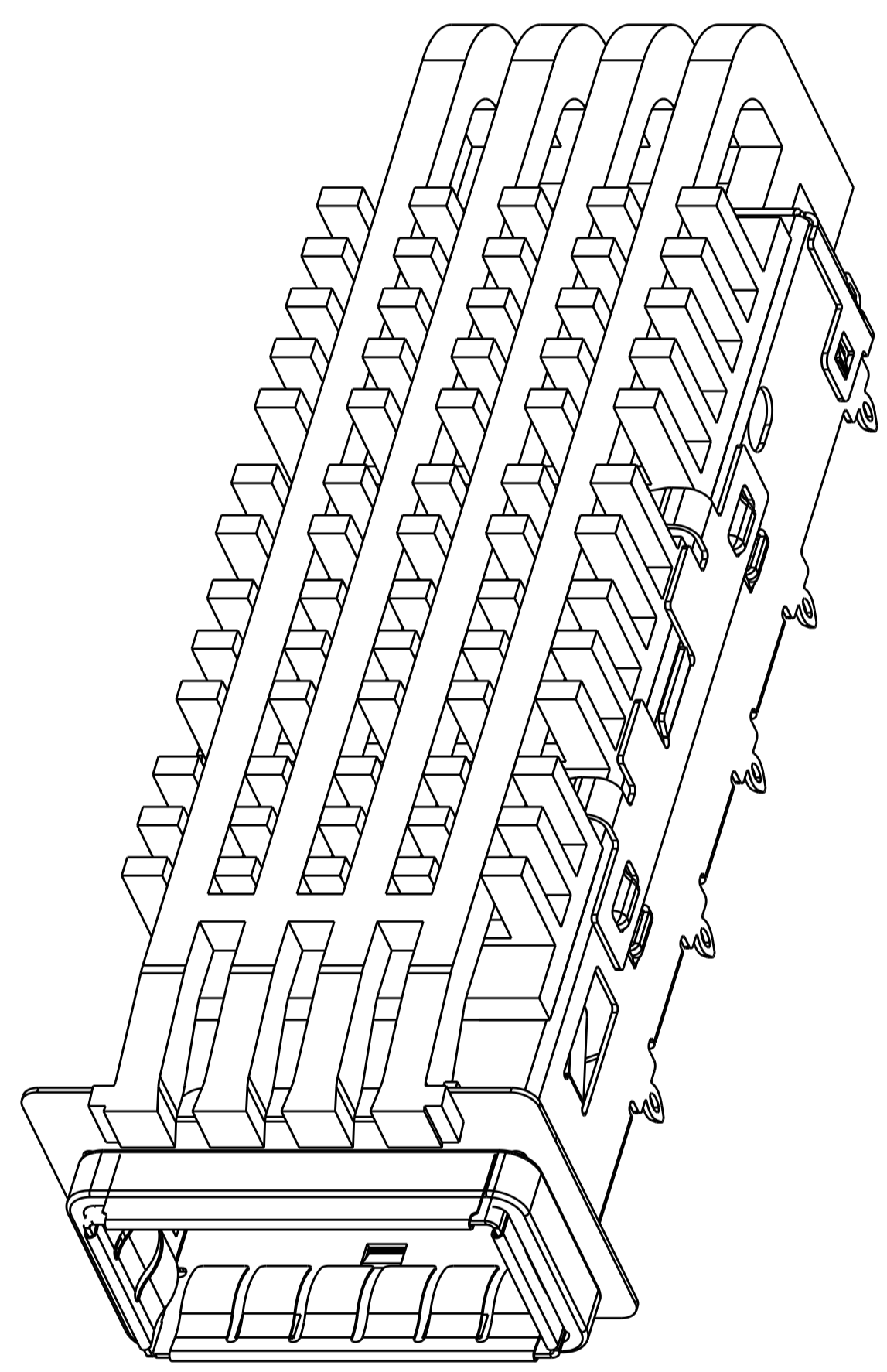

SCALE 4:1
2170539-1 AS SHOWN

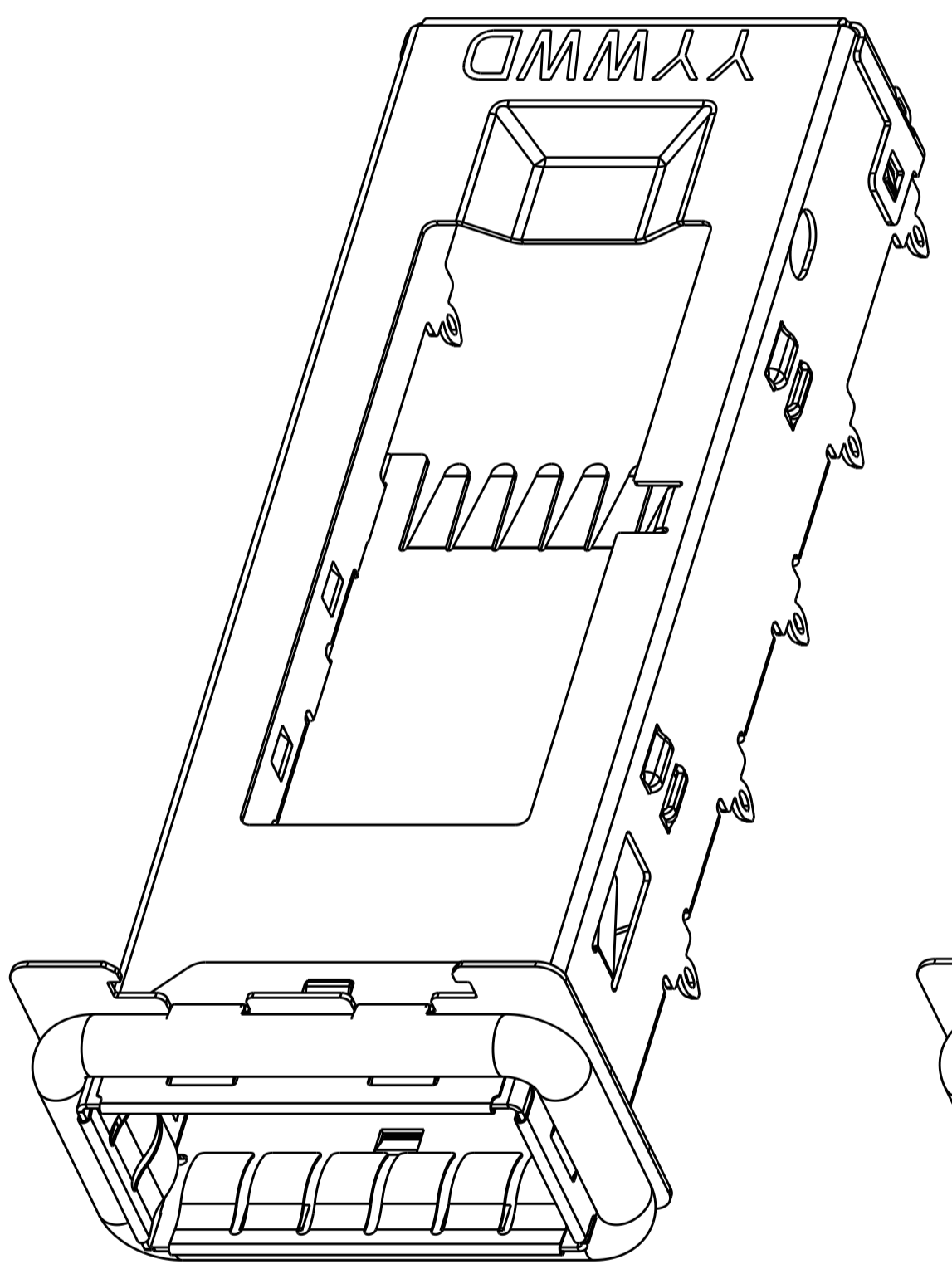

SCALE 4:1
2170539-2 AS SHOWN

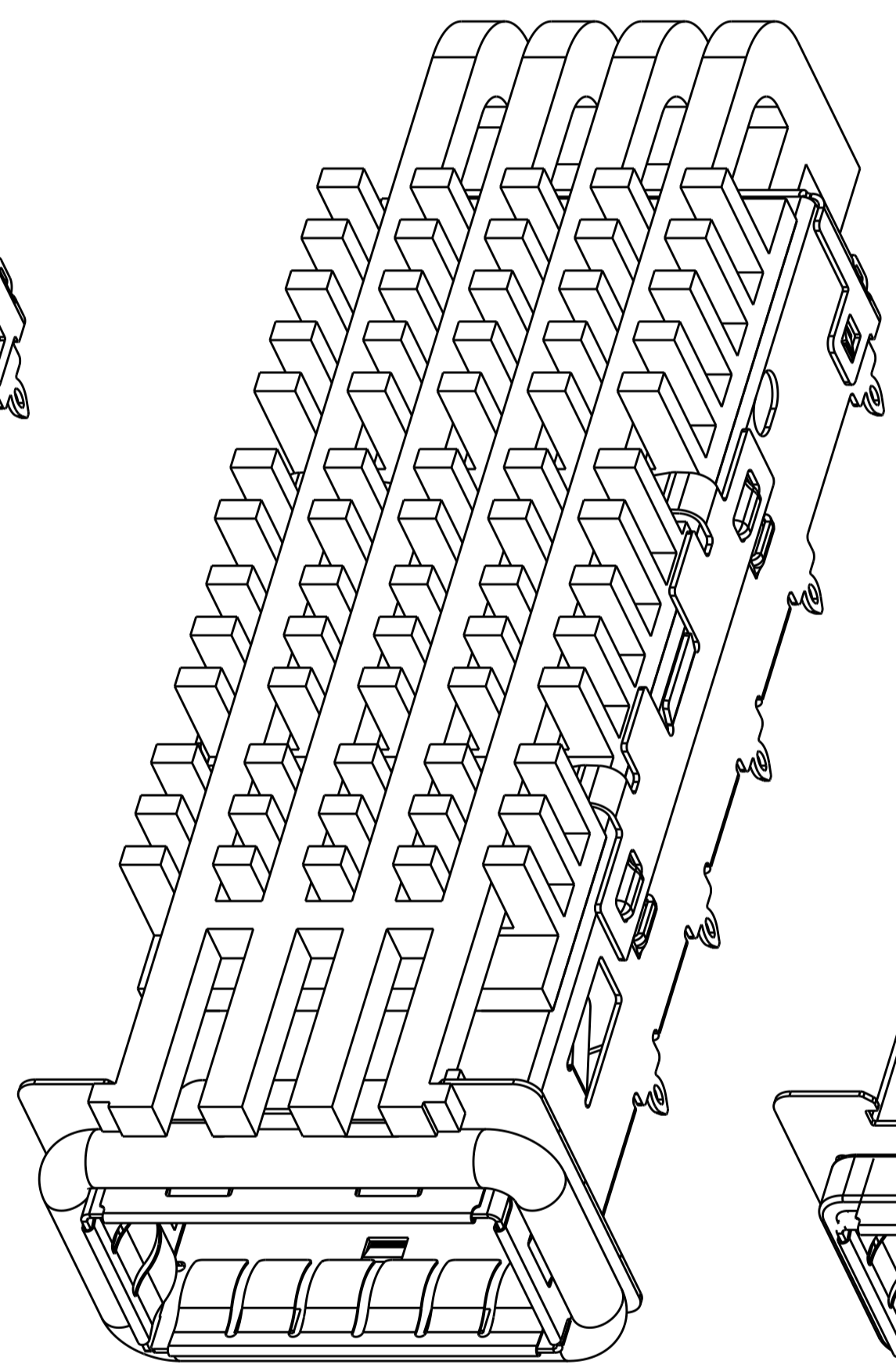

SCALE 4:1
2170539-3 AS SHOWN

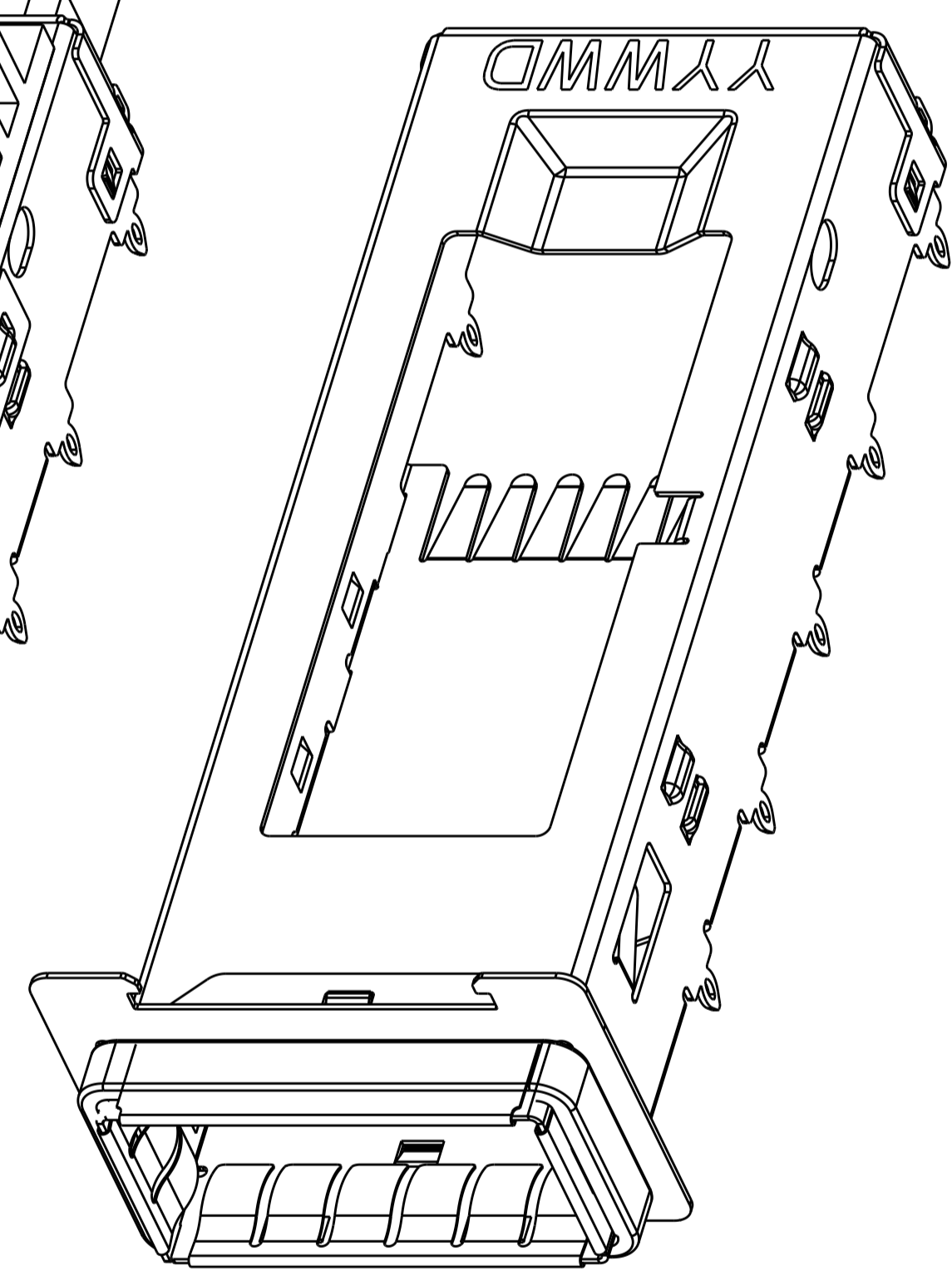

SCALE 4:1
2170539-4 AS SHOWN

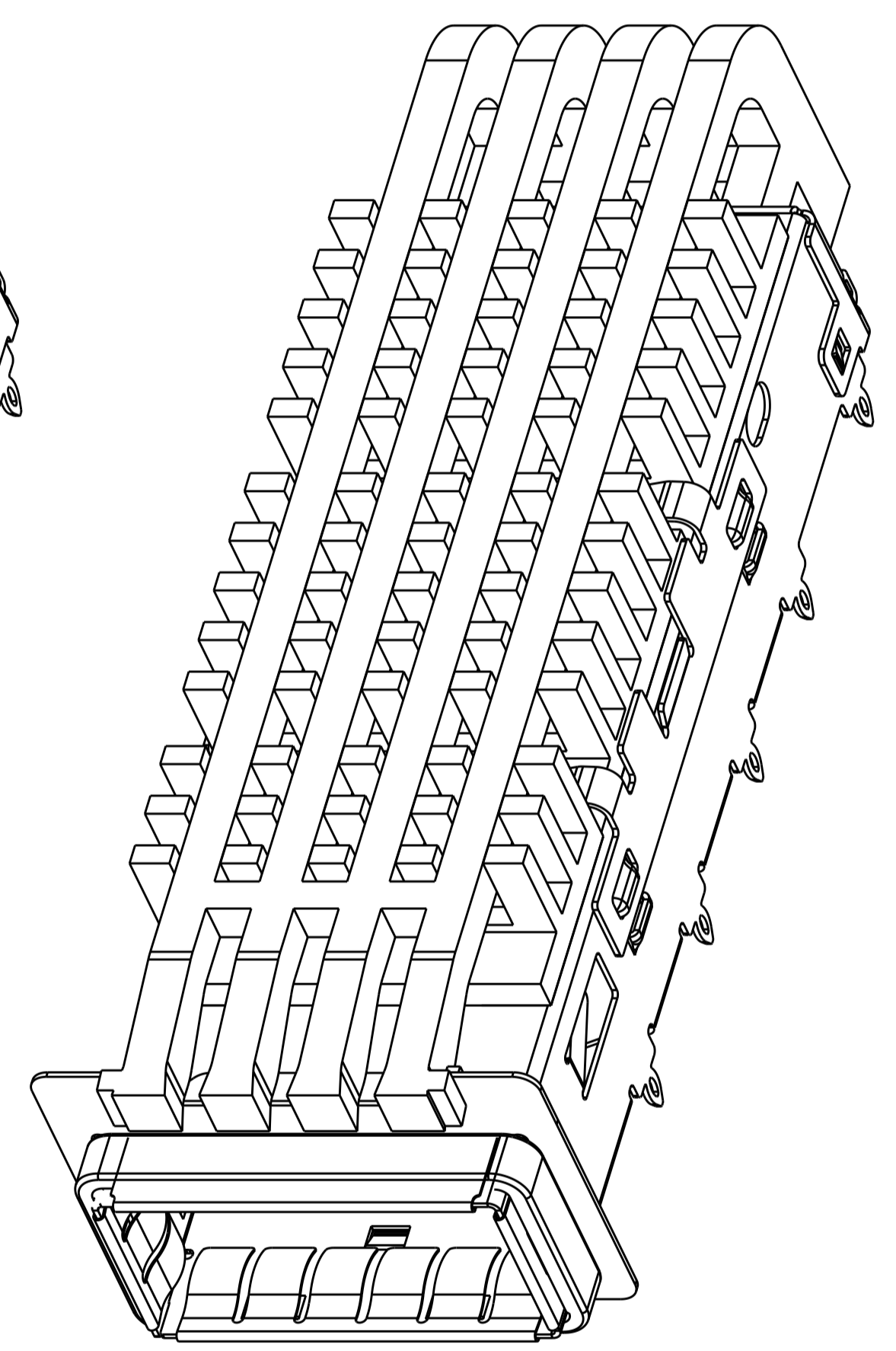

SCALE 4:1
2170539-5 AS SHOWN

THIS DRAWING IS A CONTROLLED DOCUMENT.		DWN TIM XUE 14MAY2013	
DIMENSIONS:		CHK JASON YANG 14MAY2013	
mm	TOLERANCES UNLESS OTHERWISE SPECIFIED:	APVD ALEX CAI 14MAY2013	NAME CAGE ASSEMBLY, QSFP+, W/ HEAT SINK, EMI GASKET AND LIGHT PIPE
	0 PLC ± 1 PLC ±0.5 2 PLC ±0.13 3 PLC ±0.013 4 PLC ±0.0001 ANGLES ±	PRODUCT SPEC 108-2286	SIZE 114-13217
MATERIAL	FINISH	APPLICATION SPEC 114-13217	RESTRICTED TO
-	-	WEIGHT	A100779C=2170539
-	-	Customer Drawing	SCALE 4:1 SHEET 5 OF 6 REV A

LOC	DIST	REVISIONS			
P.	LTN	DESCRIPTION	DATE	DMN	APVD
-	-	SEE SHEET 1	-	-	-

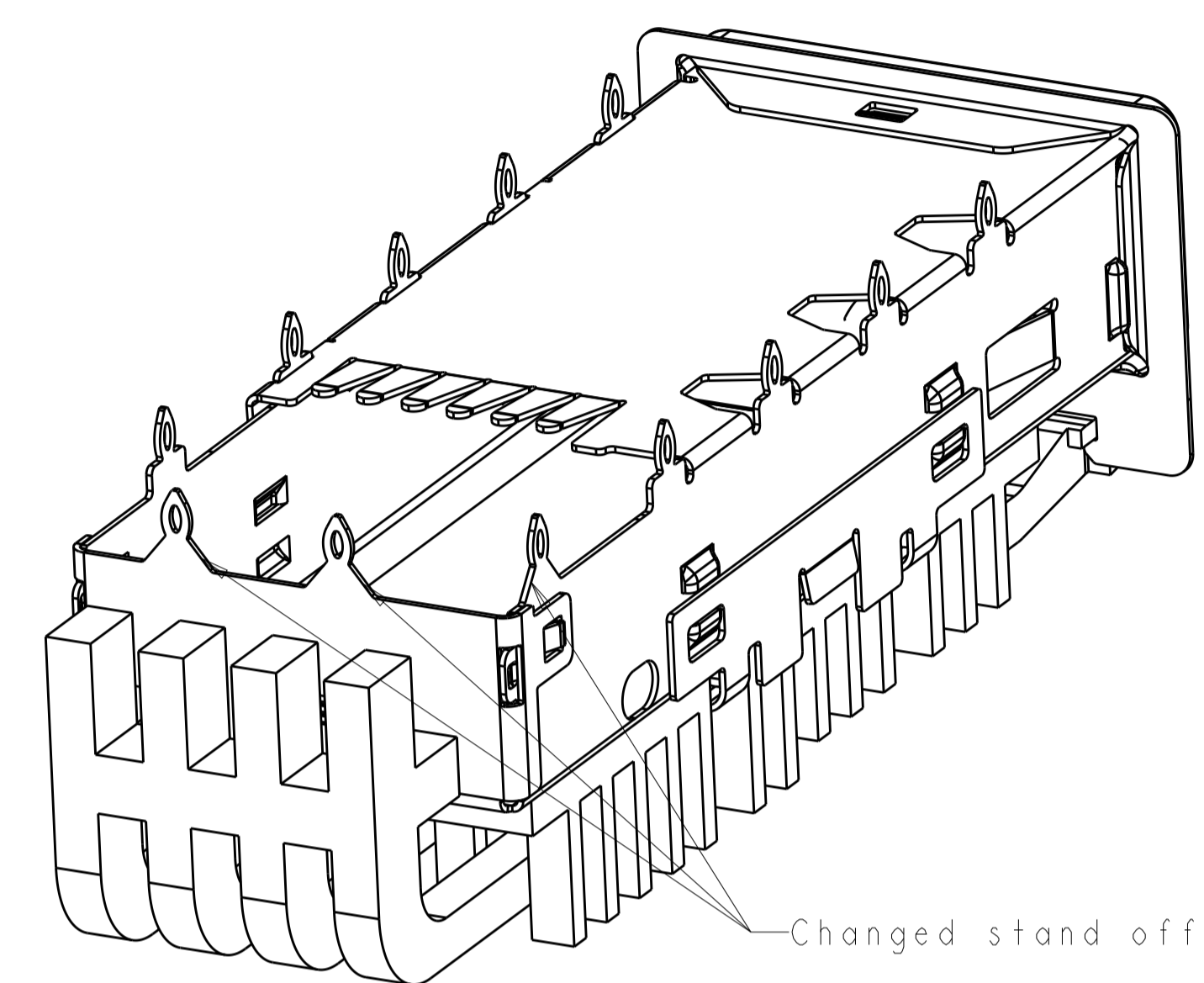
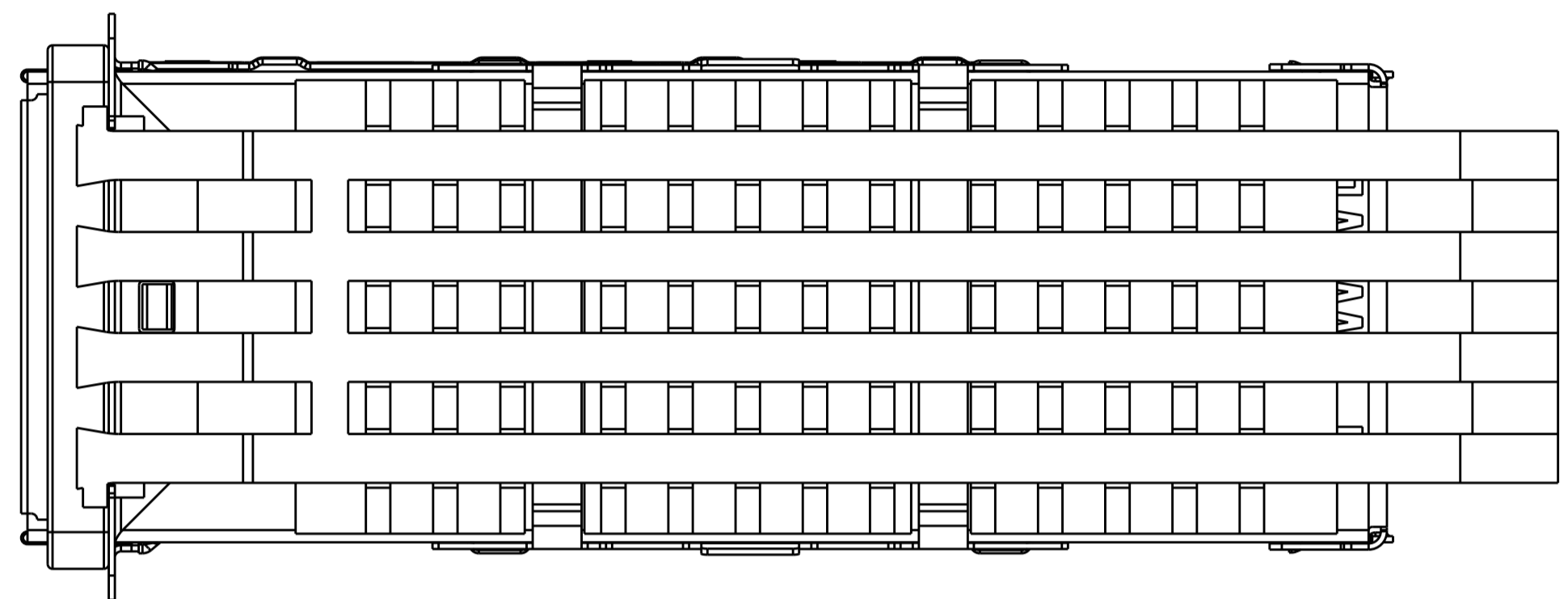

Changed stand off shape on 3 EON

SCALE 4:1

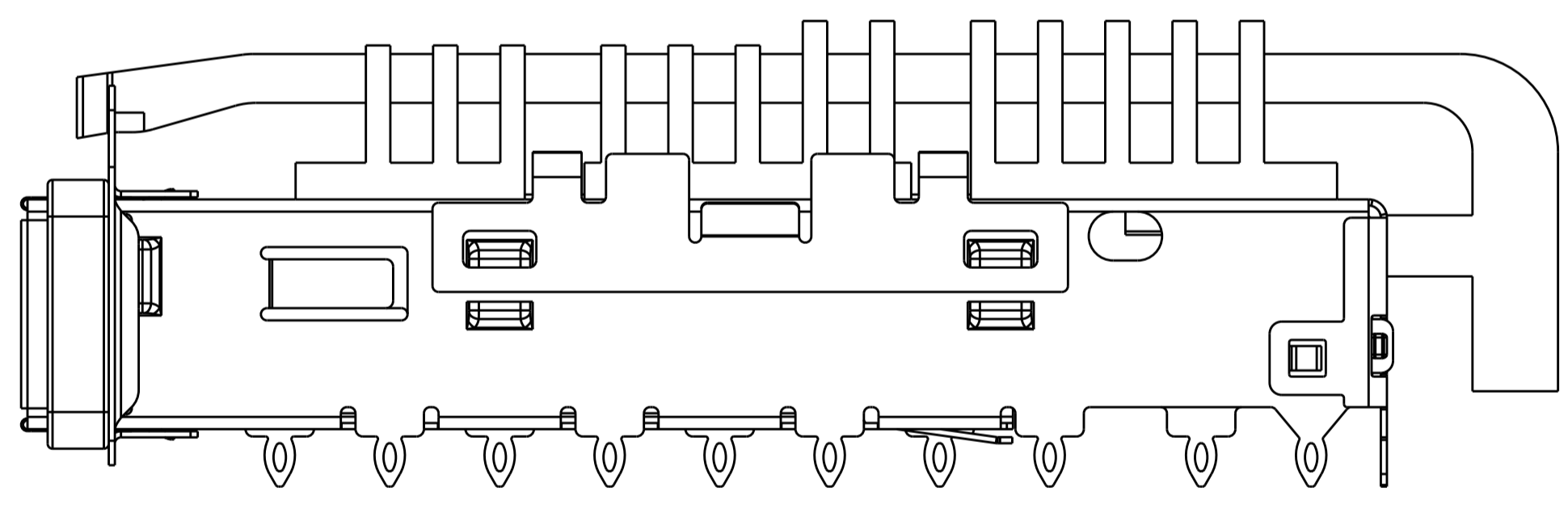

SCALE 4:1

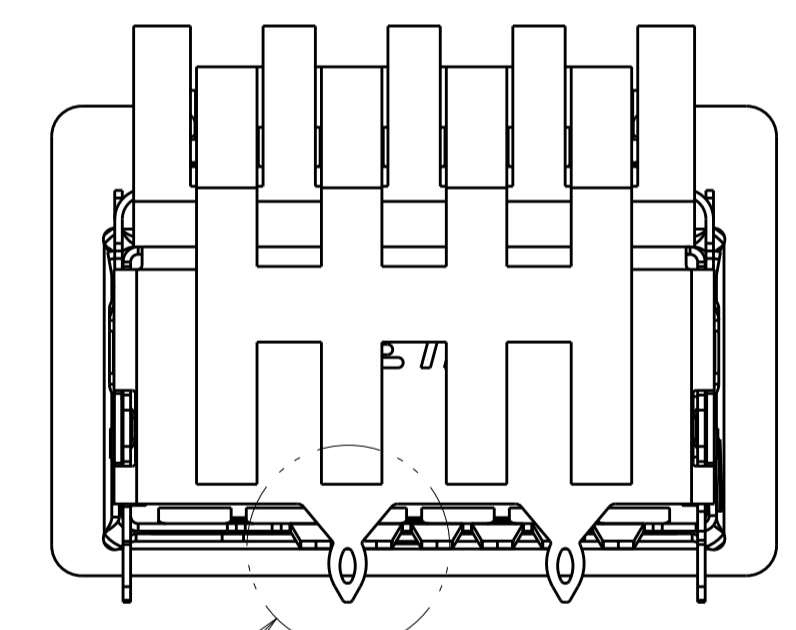

SEE DETAIL A

2170539-6 ARE AS SHOWN, UN-SPECIFIED DIMENSIONS
 ALL REFER 2170539-1

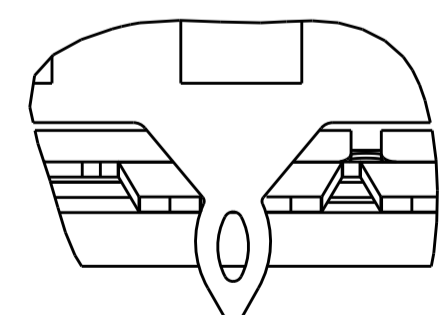

DETAIL A
 SCALE 8:1

SAN HEAT SINK WITH TWO PIN HEIGHT, HEAT SINK CLIP HORN SHAPE LP & SOLID GASKET, CHANGED 3 STAND OFF SHAPE		2170539-6
DESCRIPTION		PART NO

THIS DRAWING IS A CONTROLLED DOCUMENT.		DMN TIM XUE 14MAY2013	
DIMENSIONS:		CHK JASON YANG 14MAY2013	
mm	TOLERANCES UNLESS OTHERWISE SPECIFIED:	APVD ALEX CAI 14MAY2013	NAME CAGE ASSEMBLY, QSFP+, W/ HEAT SINK, EMI GASKET AND LIGHT PIPE
0 PLC ±0.5	1 PLC ±0.13	PRODUCT SPEC 108-2286	SIZE 114-13217
2 PLC ±0.013	3 PLC ±0.001	APPLICATION SPEC	RESTRICTED TO
4 PLC ±0.0001	ANGLES ±0.0001	WEIGHT	A100779C=2170539
MATERIAL	FINISH	Customer Drawing	SCALE 4:1 SHEET 6 OF 6 REV A