

REVISIONS

P	LTR	DESCRIPTION	DATE	DWN	APVD
	F8	REVISED PER ECN-22-150900	27APR2022	RK	CSD

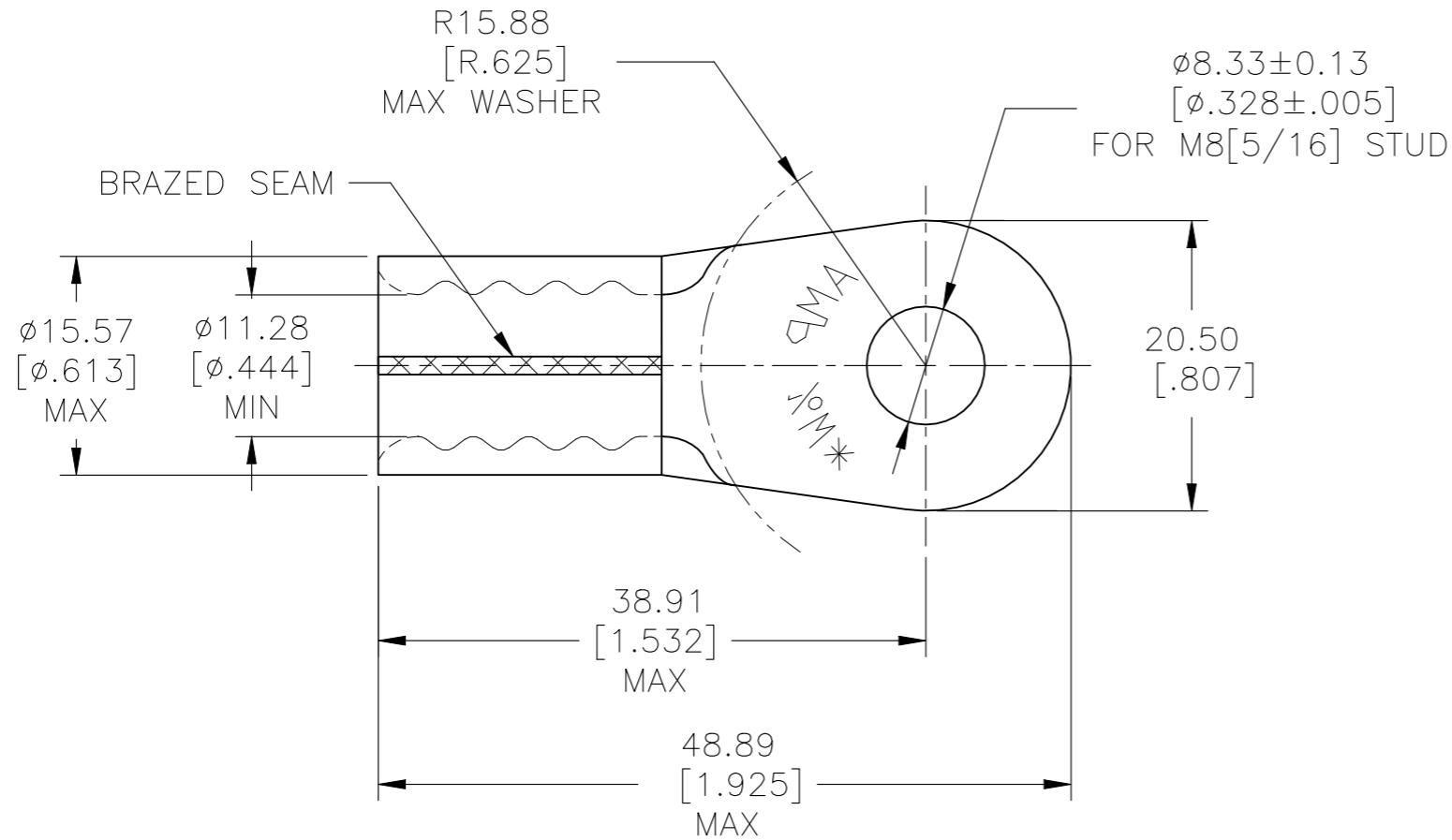

AMP WIRE RANGE	E13288 Listed
1/0 AWG SOLID OR STRANDED	1/0 AWG SOLID OR STRANDED

LR7189 Certified
1/0 AWG SOLID OR STRANDED

- TIN PL 0.00254[.000100] MIN THK PER ASTM B-545.
- NICKEL PLATE 0.00762 [.000300] MIN EXT. THK PER QQ-N-290.
- 3 NOTE DELETED
- 4 MATERIAL THICKNESS: 1.78±0.05[.070±.002]
- GOLD PLATE 0.00127[.000050] MIN EXT. THK. PER ASTM B488, TYPE 1, CODE C OVER NICKEL PLATE 0.00127[.000050] MIN. EXT. THK PER SAE AMS QQ-N-290 OVER Cu FLASH PER SAE AMS 2418.

260°C [500°F]	50	LOOSE PIECE		321867-3
343°C [649°F]	50	LOOSE PIECE		321867-2
170°C [338°F]	50	LOOSE PIECE		321867
MAX TEMP RATING	QTY	PACKAGE TYPE	FINISH	PART NO.

MAX RECOMMENDED OPERATING TEMPERATURE: SEE TABLE	THIS DRAWING IS A CONTROLLED DOCUMENT.		DWN DK SCHRUM 8/30/91	STE TE Connectivity		
	VOLTAGE RATING: N/A	DIMENSIONS: mm [INCHES]	TOLERANCES UNLESS OTHERWISE SPECIFIED: 0 PLC ± - 1 PLC ± - 2 PLC ± 0.20[.008] 3 PLC ± - 4 PLC ± - ANGLES ± -			
CIRCULAR MIL AREA: 42.4-60.6mm ² [83,700-118,500] SOLID OR STRANDED	MATERIAL COPPER PER ASTM B152 ANNEALED	FINISH SEE TABLE	PRODUCT SPEC -	APPLICATION SPEC -	WEIGHT -	TERMINAL, RING TONGUE, SOLISTRAND, STRATO-THERM, WIRE SIZE 50.0mm ² [1/0] AWG
			SIZE A3	CAGE CODE 00779	DRAWING NO C-321867	RESTRICTED TO -
			CUSTOMER DRAWING		SCALE 2:1	SHEET 1 OF 1
					REV F8	