

High Performance Selectable 1:4 Differential Fanout Buffer

Features

- 4 differential outputs with 2 banks
- User configurable output signaling standard for each bank: LVDS or LVPECL or HCSL
- LVCMOS reference output up to 200MHz
- Up to 1.5GHz output frequency for differential outputs
- Ultra low additive phase jitter: < 0.03 ps (typ) (differential 156.25MHz, 12KHz to 20MHz integration range)
- Selectable reference inputs support either single-ended or differential or Xtal
- Low skew between outputs within banks (<40ps)
- Low delay from input to output (Tpd typ. < 1.5ns)
- Separate Input output supply voltage for level shifting
- 2.5V / 3.3V power supply
- Industrial temperature support
- TSSOP-28 package

Description

The PI6C49S1504 is a high performance fanout buffer device which supports up to 1.5GHz frequency. The device also uses Pericom's proprietary input detection technique to make sure illegal input conditions will be detected and reflected by output states. This device is ideal for systems that need to distribute low jitter clock signals to multiple destinations.

Applications

- Networking systems including switches and Routers
- High frequency backplane based computing and telecom platforms

Block Diagram

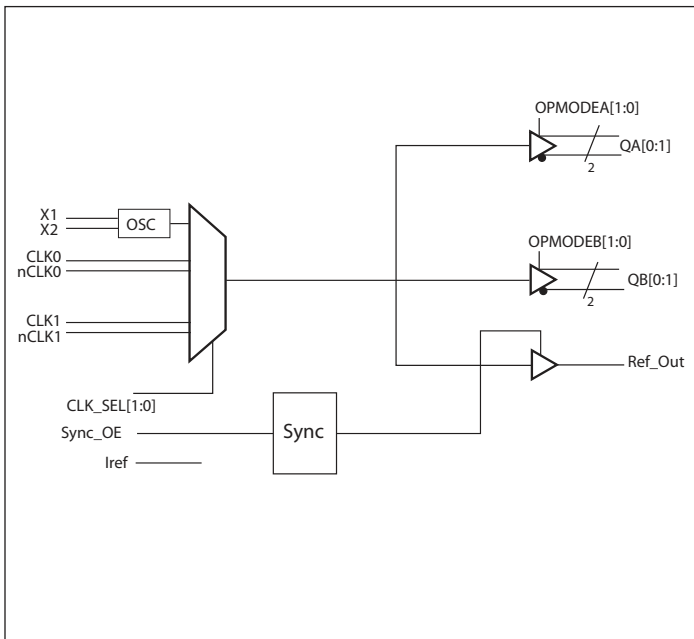

Pin Configuration (28-Pin TSSOP)

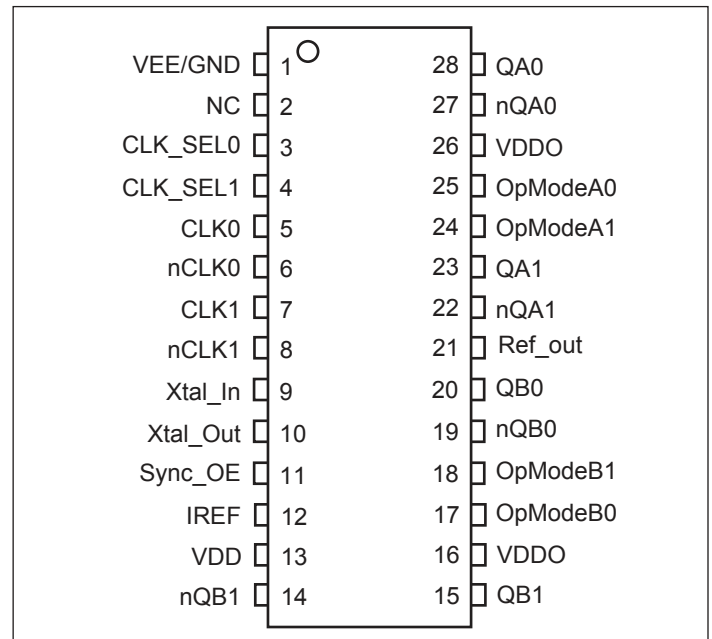

Pinout Table

Pin #	Pin Name	Type	Description
1	V _{EE}	Power	Negative power supply
2	NC	-	No Connect
3	CLK_SEL0	Input	Clock input source selection pin
4	CLK_SEL1	Input	Clock input source selection pin
5, 6	CLK0 nCLK0	Input	Differential clock input
7, 8	CLK1 nCLK1	Input	Differential clock input
9	XTAL_In	Input	Xtal input pin
10	XTAL_Out	Output	Xtal output pin
11	Sync_OE	Input	Synchronous output enable for Ref_Out, see Table 3 for functions
12	IREF	Output	External 475Ω resistor connection to set differential output current
13	V _{DD}	Power	Power supply for core
14, 15	nQB1 QB1	Output	Differential output clock
16, 26	V _{DDO}	Power	Power supply for outputs
17	OpModeB0	Input	Bank B output clock type selection pin
18	OpModeB1	Input	Bank B output clock type selection pin
19, 20	nQB0 QB0	Output	Differential output clock
21	Ref_Out	Output	Reference output clock
22, 23	nQA1 QA1	Output	Differential output clock
24	OpModeA1	Input	Bank A output clock type selection pin
25	OpModeA0	Input	Bank A output clock type selection pin
27, 28	nQA0 QA0	Output	Differential output clock

Function Table

Table 1: Input select function

CLK_SEL [1]	CLK_SEL [0]	Function
0	0	XTAL is the selected input
0	1	CLK0 is the selected reference input
1	X	CLK1 is the selected reference input

Table 2: Output Mode select function

OPMODEA/B [1]	OPMODEA/B [0]	Output Bank A / Bank B Mode
0	0	LVPECL
0	1	LVDS
1	0	HCSL
1	1	Hi-Z

Table 3: Reference output enable function

Sync_OE	Ref_Out
0	Hi-Z
1	Output enabled

Maximum Ratings (Above which the useful life may be impaired. For user guidelines, not tested)

Storage temperature.....	-55 to +150°C
Supply Voltage to Ground Potential (V _{DD} , V _{DDO}) .	-0.5 to +4.6V
Inputs (Referenced to GND)	-0.5 to V _{CC} +0.5V
Clock Output (Referenced to GND).....	-0.5 to V _{CC} +0.5V
Latch up.....	200mA

Note:
Stresses greater than those listed under MAXIMUM RATINGS may cause permanent damage to the device. This is a stress rating only and functional operation of the device at these or any other conditions above those indicated in the operational sections of this specification is not implied. Exposure to absolute maximum rating conditions for extended periods may affect reliability.

Power Supply Characteristics and Operating Conditions

Symbol	Parameter	Test Condition	Min.	Typ.	Max.	Units
V _{DD}	Core Supply Voltage		2.375		3.465	V
V _{DDO}	Output Supply Voltage		2.375		3.465	V
I _{DD}	Core Power Supply Current				70	mA
I _{DDO}	Output Power Supply Current	All LVPECL outputs unloaded			60	
		All LVDS outputs loaded			70	
		All HCSL outputs unloaded			45	
T _A	Ambient Operating Temperature		-40		85	°C

DC Electrical Specifications - Differential Inputs

Symbol	Parameter	Test Condition	Min.	Typ.	Max.	Units
I _{IH}	Input High current	Input = V _{DD}			150	uA
I _{IL}	Input Low current	Input = GND	-150			uA
C _{IN}	Input capacitance			3		pF
V _{IH}	Input high voltage				V _{DD} +0.3	V
V _{IL}	Input low voltage		-0.3			V
V _{ID}	Input Differential Amplitude PK-PK		0.15		1.3	V
V _{CM}	Common mode input voltage	V _{ID} > 0.4V	GND + 0.26		V _{DD} -0.85	V

DC Electrical Specifications - LVCMOS Inputs

Symbol	Parameter	Conditions	Min.	Typ.	Max.	Units
I _{IH}	Input High current	Input = V _{DD}			150	uA
I _{IL}	Input Low current	Input = GND	-150			uA
V _{IH}	Input high voltage	V _{DD} =3.3V	2.0		V _{DD} +0.3	V
V _{IL}	Input low voltage	V _{DD} =3.3V	-0.3		0.8	V
V _{IH}	Input high voltage	V _{DD} =2.5V	1.7		V _{DD} +0.3	V
V _{IL}	Input low voltage	V _{DD} =2.5V	-0.3		0.7	V

DC Electrical Specifications- LVPECL Outputs

Parameter	Description	Conditions	Min.	Typ.	Max.	Units
V _{OH}	Output High voltage	V _{DD} =3.3V	2.1		2.6	V
		V _{DD} =2.5V	1.3		1.6	
V _{OL}	Output Low voltage	V _{DD} =3.3V	1.2		1.8	V
		V _{DD} =2.5V	0.4		0.8	

DC Electrical Specifications- LVDS Outputs

Parameter	Description	Conditions	Min.	Typ.	Max.	Units
V _{OD}	Differential Output Voltage		0.35		0.55	V
V _{ocm}	Output commode voltage		1.1	1.2	1.3	V
DV _{Ocm}	Change in V _{ocm} between completely output states				50	mV
R _o	Output impedance		85		140	Ω

DC Electrical Specifications- HCSL Outputs

Parameter	Description	Conditions	Min.	Typ.	Max.	Units
V _{OH}	Output High voltage		520		900	mV
V _{OL}	Output Low voltage		0		150	mV

AC Electrical Specifications – Differential Outputs

Parameter	Description	Conditions	Min.	Typ.	Max.	Units
F _{OUT}	Clock output frequency	LVPECL, LVDS			1500	MHz
		HCSL			250	
T _r	Output rise time	From 20% to 80%, LVPECL, LVDS	120	150	300	ps
		From 20% to 80%, HCSL	350	460	650	ps
T _f	Output fall time	From 80% to 20%, LVPECL, LVDS	120	150	300	ps
		From 80% to 20%, HCSL	350	460	650	ps
T _{ODC}	Output duty cycle	Frequency<650MHz, LVPECL	48		52	%
		Frequency<650MHz, LVDS	47		53	%
V _{PP}	Output swing Single-ended	LVPECL outputs	400			mV
		LVDS outputs, <650MHz	250			mV
		HCSL outputs	480			mV
T _j	Buffer additive jitter RMS			0.03		ps
V _{CROSS}	Absolute crossing voltage	HCSL	160		460	mV
DV _{CROSS}	Total variation of crossing voltage	HCSL			140	mV
T _{SK}	Output Skew	10 outputs devices, outputs in same tank, with same load, at DUT.		40		ps
T _{PD}	Propagation Delay			1500		ps
T _{OD}	Valid to HiZ		200			ns
T _{OE}	HiZ to valid		200			ns

Notes:

1. This parameter is guaranteed by design

Propagation Delay

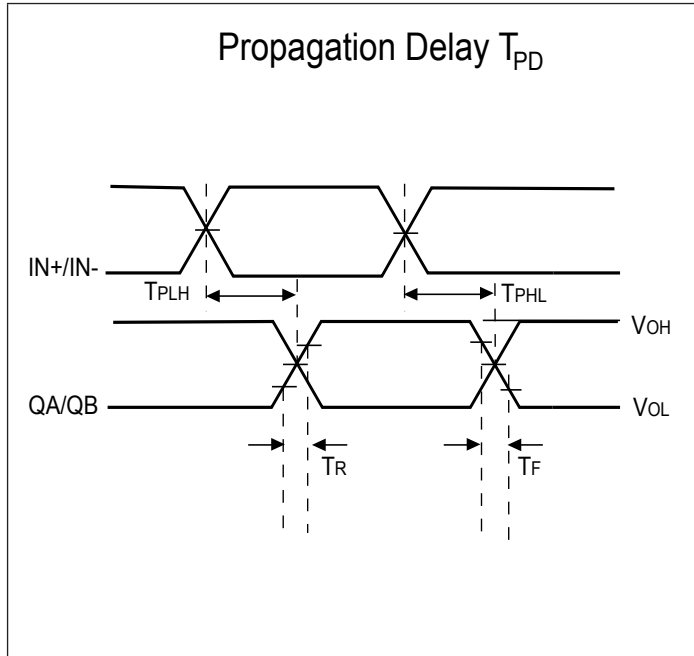

Output Skew

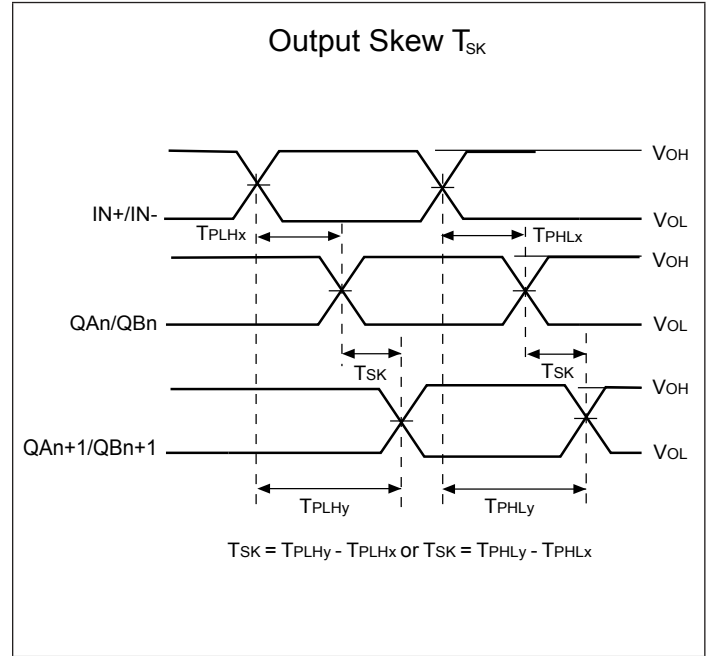

Part to Part Skew

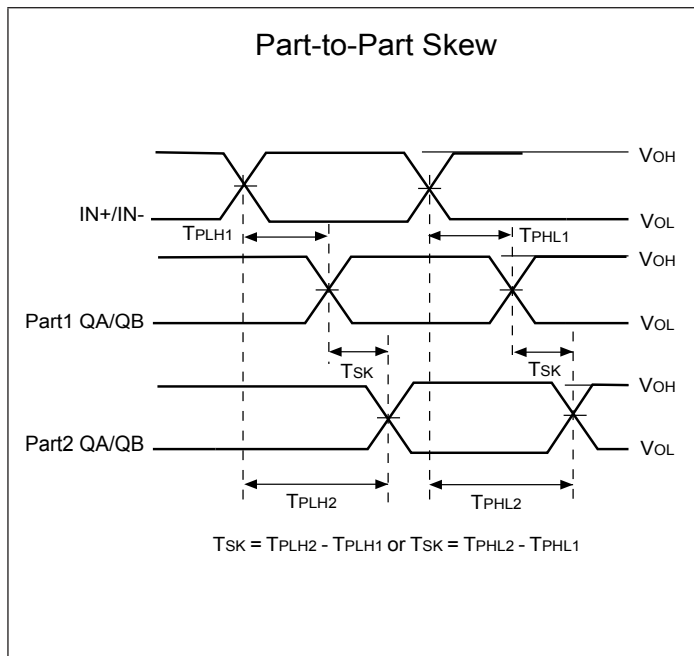

Configuration Test Load Board Termination for HCSL Outputs

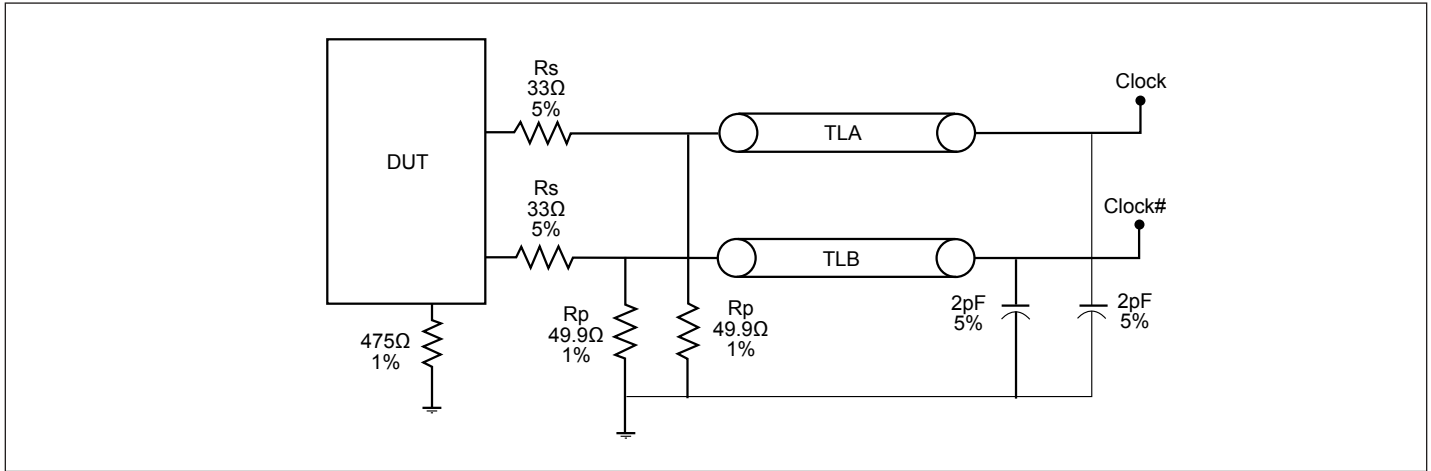

Configuration Test Load Board Termination for LVPECL/ LVDS Outputs

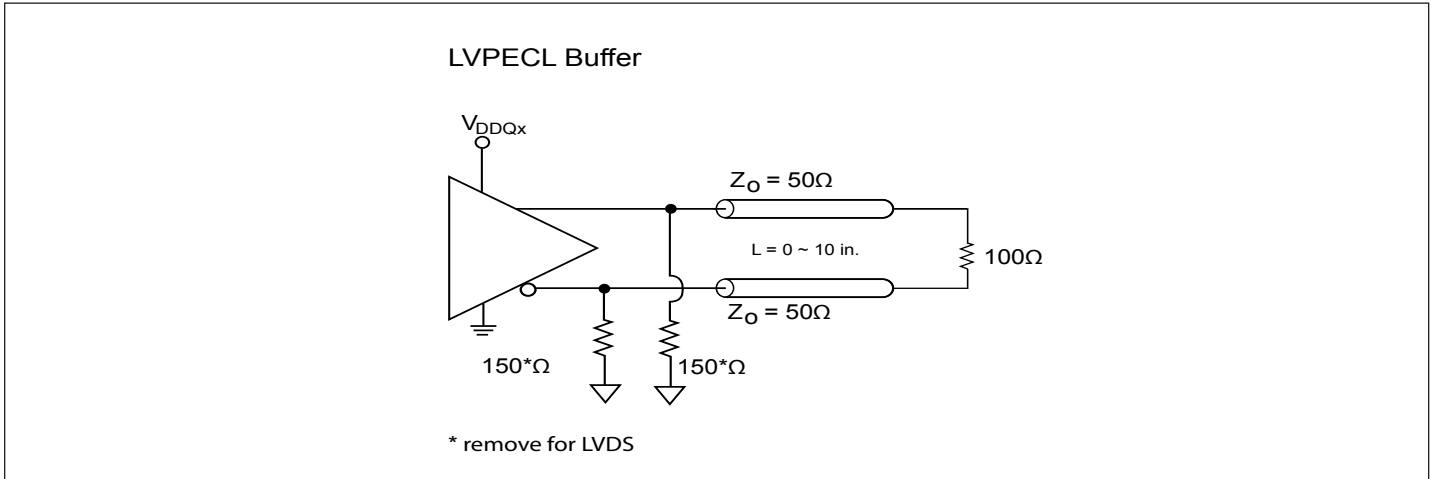

Configuration Test Load Board Termination for LVCMOS Outputs

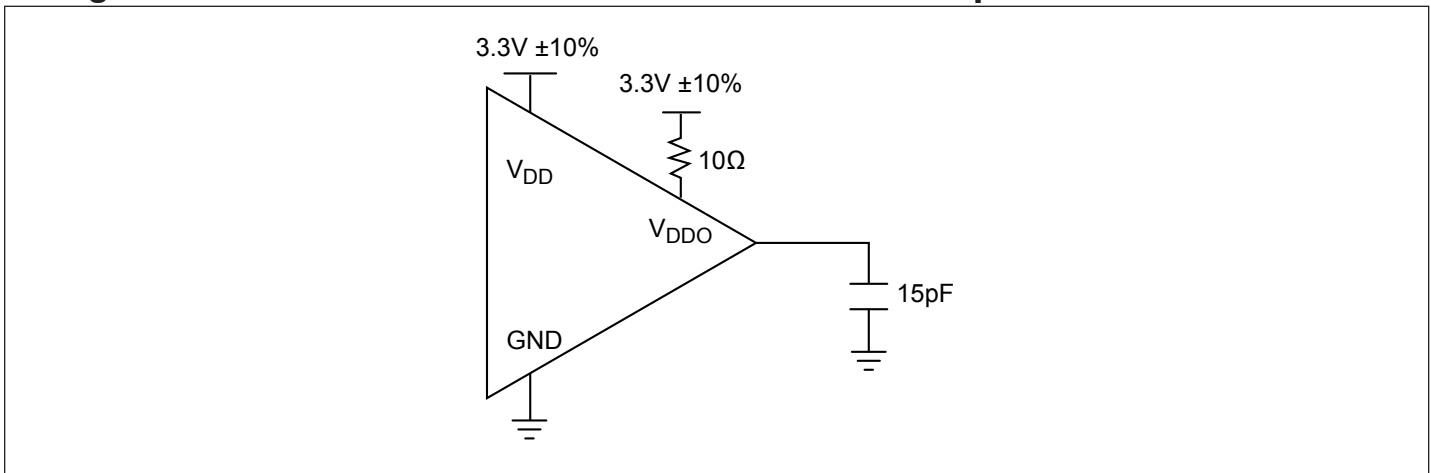

PI6C49S1504

Packaging Mechanical: 28-Pin TSSOP (L)

SYMBOLS	MIN.	NOM.	MAX.
A	-	-	1.20
A1	0.05	-	0.15
A2	0.80	1.00	1.05
b	0.19	-	0.30
c	0.09	-	0.20
D	9.60	9.70	9.80
E1	4.30	4.40	4.50
E	6.20	6.40	6.60
e	0.65 BSC		
L1	1.00 REF		
L	0.45	0.60	0.75
S	0.20	-	-
θ	0°	-	8°

NOTES:
 1. ALL DIMENSIONS IN MILLIMETERS. ANGLES IN DEGREES.
 2. JEDEC MO-153F
 3. DIMENSIONS DOES NOT INCLUDE MOLD FLASH, PROTRUSIONS OR GATE BURRS.

PERICOM
Enabling Serial Connectivity

DATE: 03/31/16

DESCRIPTION: 28-Pin, 173mil Wide TSSOP

PACKAGE CODE: L (L28)

DOCUMENT CONTROL #: PD-1313

REVISION: F

16-0076

Note: For latest package info, please check: <http://www.pericom.com/support/packaging/packaging-mechanicals-and-thermal-characteristics/>

Ordering Information⁽¹⁻³⁾

Ordering Code	Package Code	Package Type	Operating Temperature
PI6C49S1504LIE	L	28-pin, 173mil Wide (TSSOP)	-40 °C to 85 °C
PI6C49S1504LIEX	L	28-pin, 173mil Wide (TSSOP), Tape & Reel	-40 °C to 85 °C

Notes:

1. Thermal characteristics can be found on the company web site at www.pericom.com/packaging/
2. "E" denotes Pb-free and Green
3. Adding an "X" at the end of the ordering code denotes tape and Reel packaging