

A

DATUM G ← - - -> FC
 ALIGNED WITH BOTTOM OF CARD SLOT

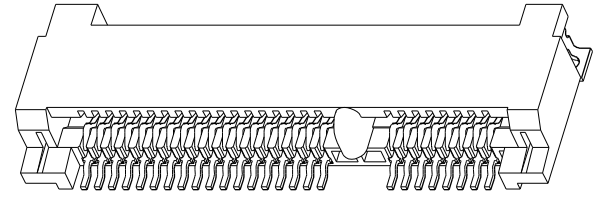

B

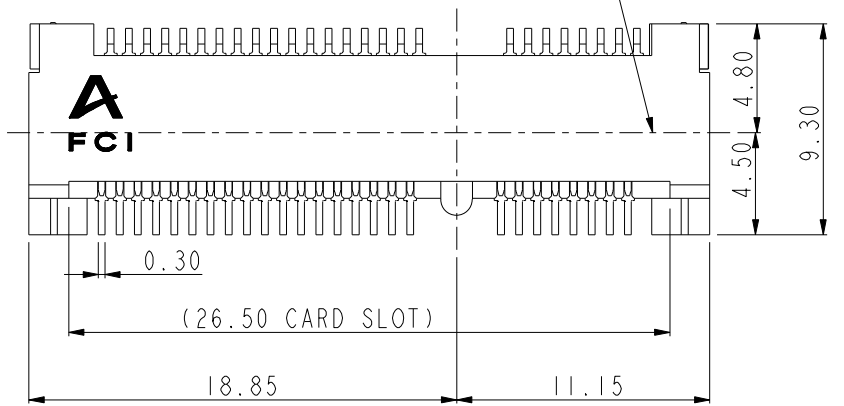
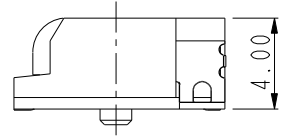
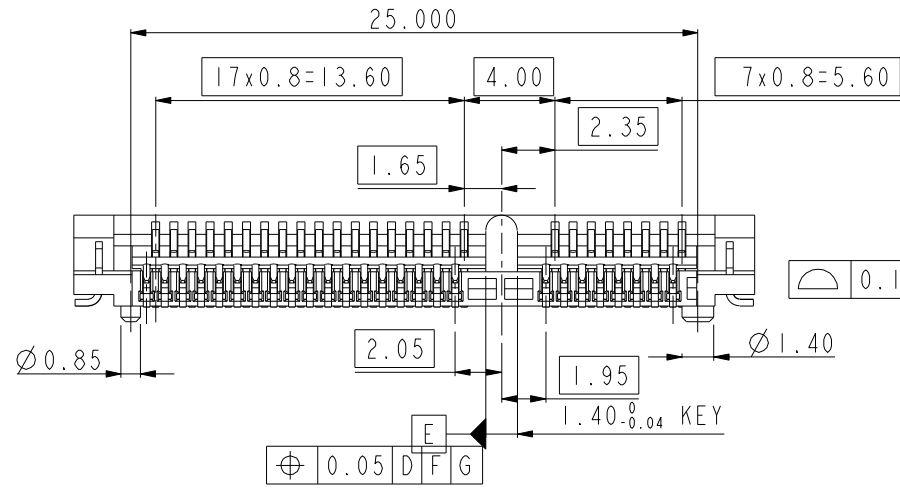

tolerance unless otherwise specified	
linear	.X±0.30 .XX±0.25 .XXX±0.15
angles	0°±2°

www.fciconnect.com		tolerance	projection	MM
Dr	RICHARD CHIU	08/10/05	Product family	size A4
Eng	RICHARD CHIU	08/10/05	Spec ref	Scale 1.000
Chr	PAUL WANG	08/10/05	Material	ECN DG09-0364
Appr	JOSEPH HSIA	08/10/05		
		title	MINI PCI EXPRESS 52P 4.0 MM HEIGHT ASSEMBLY	dwg no
		catalog no	*	customer
				sheet 1 of 5
				Rev. E

rev	ecn no	dr	date
A	T05-0203	RC	09/12/05
B	T06-0024	RC	02/07/06
C	DG06-0204	PM	05/29/06
D	DG06-0417	PM	10/16/06
E	DG09-0364	BL	11/20/09



Copyright FCI.



Copyright FCI.

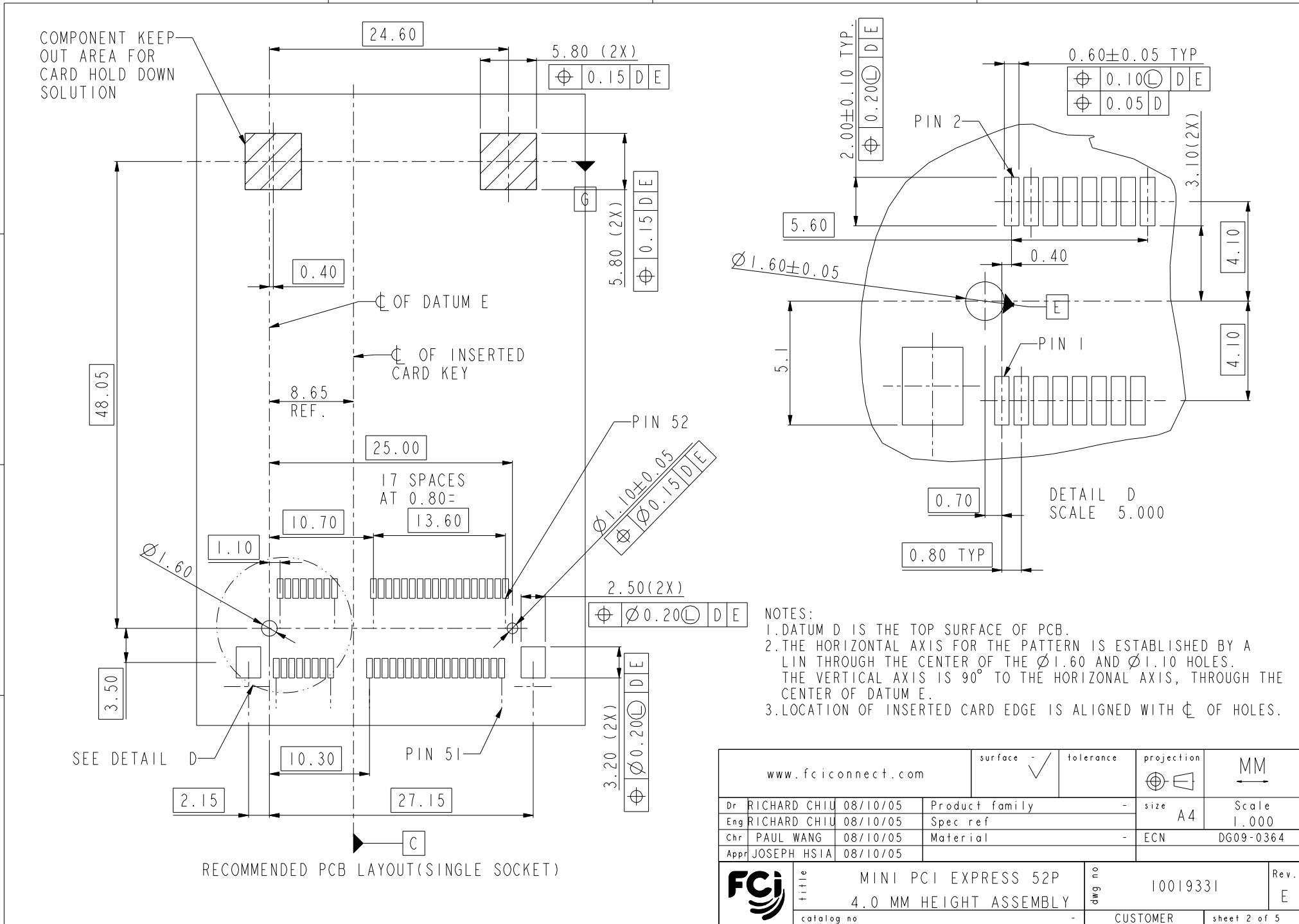

www.fciconnect.com		surface	-	tolerance	✓	projection	\varnothing	MM
Dr	RICHARD CHIU	08/10/05	Product family	-	size	A4	Scale	1.000
Eng	RICHARD CHIU	08/10/05	Spec ref	-	ECN	DG09-0364		
Chr	PAUL WANG	08/10/05	Material	-				
Appr	JOSEPH HSIA	08/10/05						
		title MINI PCI EXPRESS 52P 4.0 MM HEIGHT ASSEMBLY		dwg no 10019331		Rev. E		
catalog no		-		CUSTOMER		sheet 2 of 5		

REV F - 2006-04-17



Copyright FCI.

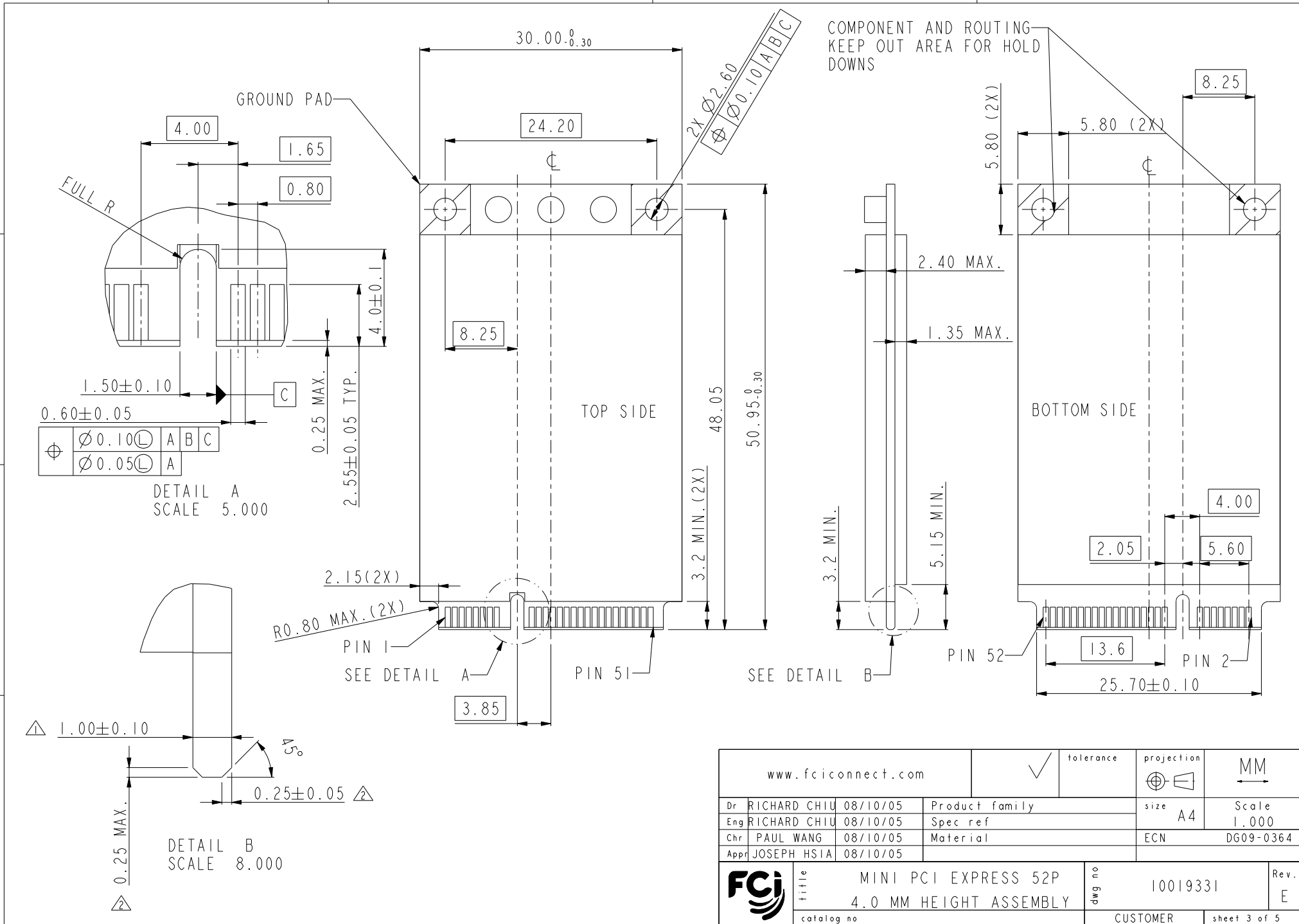

www.fciconnect.com			tolerance	projection	MM
Dr	RICHARD CHIU	08/10/05	Product family	size	Scale
Eng	RICHARD CHIU	08/10/05			
Chr	PAUL WANG	08/10/05	Spec ref	ECN	DG09-0364
Appr	JOSEPH HSIA	08/10/05	Material		
FCI			title	dwg no	Rev.
			MINI PCI EXPRESS 52P	10019331	E
			4.0 MM HEIGHT ASSEMBLY	CUSTOMER	sheet 3 of 5
			catalog no		

REV F - 2006-04-17



Copyright FCI.

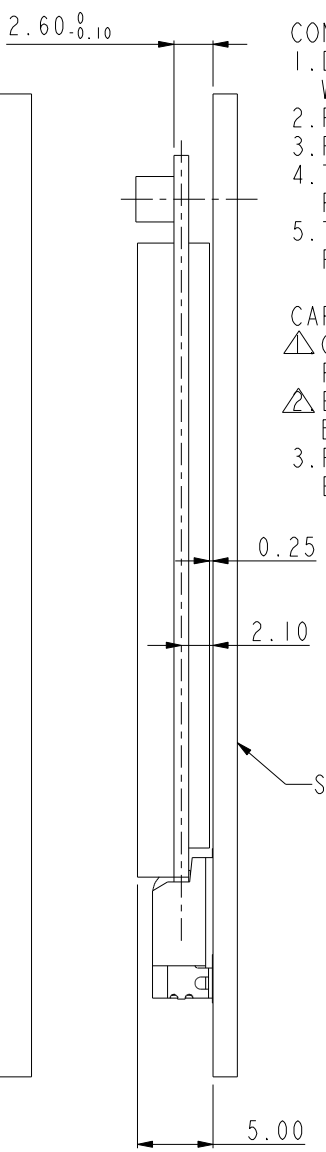
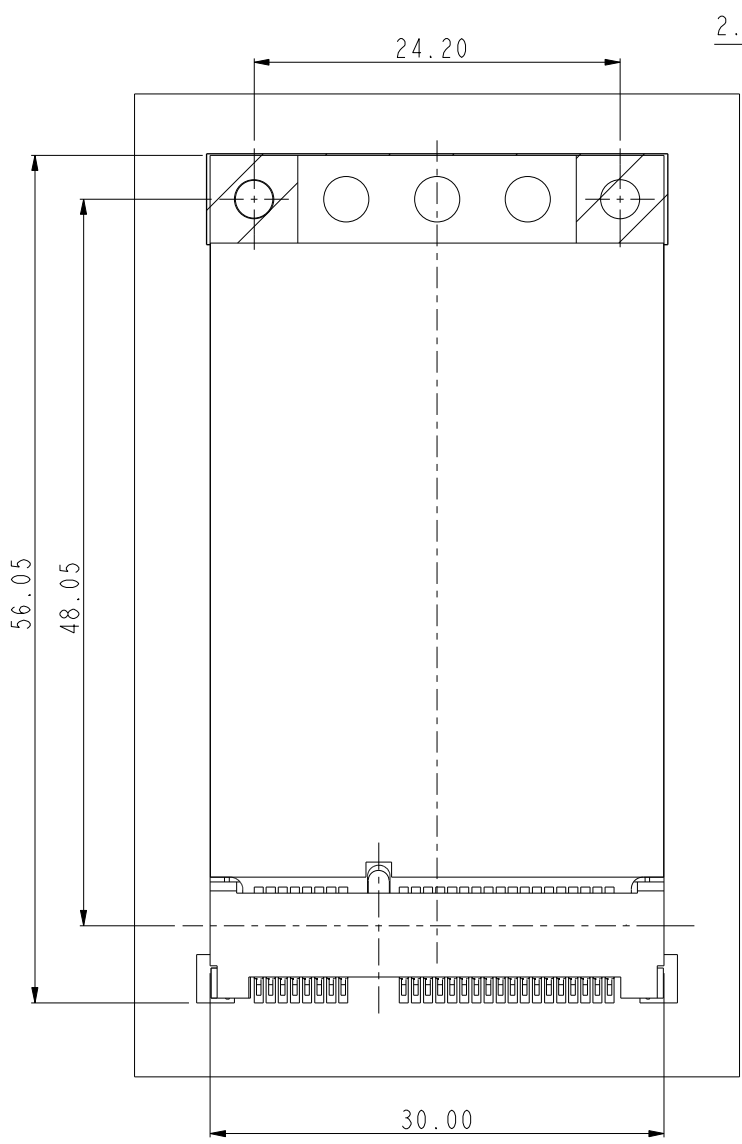

CONNECTOR NOTES:

1. DIMENSIONS AND TOLERANCE ARE IN ACCORDANCE WITH ASME Y14.5M, 1944 UNLESS OTHERWISE SPECIFIED.
2. PRODUCT SPECIFICATION: GS-12-236.
3. FCI LOGO WILL BE APPROXIMATELY LOCATED AS SHOWN ON PRINT.
4. THIS PRODUCT MEETS EUROPEAN UNION DIRECTIVES AND OTHER COUNTRY REGULATIONS AS DESCRIBED IN GS-22-008.
5. THE HOUSING WILL WITHSTAND EXPOSURE TO 260°C PEAK TEMPERATURE FOR 10 SECONDS IN IR-REFLOW APPLICATION.

CARD NOTES:

- △ CARD THICKNESS APPLIES ACROSS TABS AND INCLUDES PLATING AND /OR METALIZATION.
- △ EDGE BEVEL MUST BE PRESENT AND FREE OF CUTTING BURRS FROM PCB AND CONTACT MATERIALS.
- 3. RECOMMENDED PLATING FOR CONTACT PADS ELECTROLYTIC GOLD 0.76um.

www.fciconnect.com			✓ tolerance	projection	MM
Dr	RICHARD CHIU	08/10/05	Product family		size A4
Eng	RICHARD CHIU	08/10/05	Spec ref		Scale 1.000
Chr	PAUL WANG	08/10/05	Material		ECN DG09-0364
Appr	JOSEPH HSIA	08/10/05			
	title	MINI PCI EXPRESS 52P 4.0 MM HEIGHT ASSEMBLY		dwg no	10019331
	catalog no	*	CUSTOMER	Rev.	E
				sheet 4 of 5	

REV F - 2006-04-17

10019331-0 0 (LF)

"LF" CODE ONLY EXISTS WHEN
 TERMINAL PLATING CODE IS 7, 8 OR 9; AND HOLD DOWN PLATING
 CODES IS "2" OR "3". FOR EXPAMPLE: 10019331-0092LF OR 10019331-0093LF.

HOLD DOWN PLATING:

CODE	SOLDERTAIL	UNDERPLATE
1	100u"(Min.)Tin/Lead	50u"(1.27um) MIN. NICKEL OVERALL
2	100u" (Min.) Bright Pure Tin	50u"(1.27um) MIN. NICKEL OVERALL
3	100u" (Min.) Matte Pure Tin	50u"(1.27um) MIN. NICKEL OVERALL

CONTACT PLATING:

CODE	CONTACT	SOLDERTAIL	UNDERPLATE
1	15 u"(0.38um) MIN. GOLD	100u"(2.54um) MIN. TIN/LEAD (Bright)	50u"(1.27um) MIN. NICKEL OVERALL
2	30u"(0.76um) MIN. GOLD		
3	GOLD FLASH	100u"(2.54um) MIN. 100% TIN (Matte Tin)	50u"(1.27um) MIN. NICKEL OVERALL
7	15u"(0.38um) MIN. GOLD		
8	30u"(0.76um) MIN. GOLD		
9	GOLD FLASH		

NOTES:
 1. MATERIAL:
 HOUSING: THERMOPLASTIC, HIGH TEMP,
 UL 94V-0, COLOR BLACK.
 CONTACTS: PHOSPHOR BRONZE.
 HOLD DOWN: BRASS.
 2. PLATING:
 CONTACT: Ni UNDER PLATING. OTHERS SEE TABLE
 HOLD DOWN: Ni UNDER PLATING. OTHERS SEE TABLE.
 3. "LF" CODES ARE FOR LEAD FREE OPTIONS. SEE TABLE.



Copyright FCI.

www.fciconnect.com			<input checked="" type="checkbox"/>	tolerance	projection	MM
Dr	RICHARD CHIU	08/10/05	Product family		size	Scale
Eng	RICHARD CHIU	08/10/05	Spec ref		A4	1.000
Chr	PAUL WANG	08/10/05	Material		ECN	DG09-0364
Appr	JOSEPH HSIA	08/10/05				
	title	MINI PCI EXPRESS 52P 4.0MM HEIGHT ASSEMBLY			dwg no	10019331
	catalog no				CUSTOMER	sheet 5 of 5
				Rev.	E	