

Absolute maximum ratings

($T_a=25^\circ\text{C}$)

Symbol	Ratings	Unit
V_{DSS}	60	V
V_{GS}	± 20	V
I_D	10	A
$I_{D(pulse)}$	10 ($PW \leq 1\text{ms}$, $duty \leq 25\%$)	A
E_{AS}	30	mJ
P_T	5 ($T_a=25^\circ\text{C}$, with all circuits operating, without heatsink)	W
	30 ($T_c=25^\circ\text{C}$, with all circuits operating, with infinite heatsink)	
θ_{j-a}	25 (Junction-Air, $T_a=25^\circ\text{C}$, with all circuits operating)	$^\circ\text{C/W}$
θ_{j-c}	4.17 (Junction-Case, $T_c=25^\circ\text{C}$, with all circuits operating)	$^\circ\text{C/W}$
V_{ISO}	1000 (Between fin and lead pin, AC)	Vrms
T_{ch}	150	$^\circ\text{C}$
T_{stg}	-40 to +150	$^\circ\text{C}$

* : $V_{DD}=40\text{V}$, $L=20\text{mH}$, $I_D=1\text{A}$, unclamped, $R_G=50\Omega$, see Fig. E on page 15.

Electrical characteristics

($T_a=25^\circ\text{C}$)

Symbol	Specification			Unit	Conditions
	min	typ	max		
$V_{(BR)DSS}$	60			V	$I_D=100\mu\text{A}$, $V_{GS}=0\text{V}$
I_{GSS}			± 100	nA	$V_{GS}=\pm 20\text{V}$
I_{DSS}			100	μA	$V_{DS}=60\text{V}$, $V_{GS}=0\text{V}$
V_{TH}	1.0	2.0		V	$V_{DS}=10\text{V}$, $I_D=250\mu\text{A}$
$R_{e(yfs)}$	3.7	5.5		S	$V_{DS}=10\text{V}$, $I_D=3\text{A}$
$R_{DS(ON)}$		0.16	0.22	Ω	$V_{GS}=4\text{V}$, $I_D=3\text{A}$
C_{iss}		320		pF	$V_{DS}=10\text{V}$, $f=1.0\text{MHz}$, $V_{GS}=0\text{V}$
C_{oss}		160		pF	
C_{rss}		35		pF	
$t_{d(ON)}$		16		ns	$I_D=3\text{A}$, $V_{DD}=20\text{V}$, $R_L=6.67\Omega$, $V_{GS}=5\text{V}$, see Fig. 3 on page 16.
t_r		65		ns	
$t_{d(OFF)}$		70		ns	
t_f		45		ns	
t_{rr}		65		ns	
V_{SD}		1.05	1.5	V	$I_{SD}=5\text{A}$, $V_{GS}=0\text{V}$
			65	ns	$I_{SD}=3\text{A}$, $V_{GS}=0\text{V}$, $di/dt=100\text{A}/\mu\text{s}$

Equivalent circuit diagram

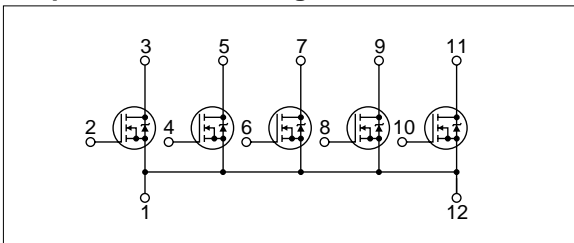

I_D - V_{DS} Characteristics (Typical)

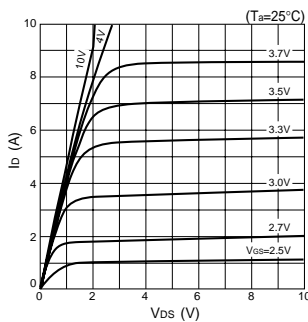

I_D - V_{GS} Characteristics (Typical)

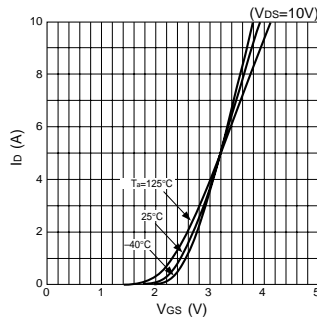

$R_{DS(ON)}$ - I_D Characteristics (Typical)

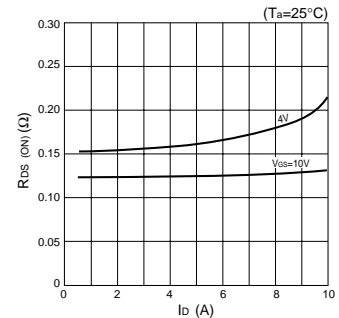

$R_{e(yfs)}$ - I_D Characteristics (Typical)

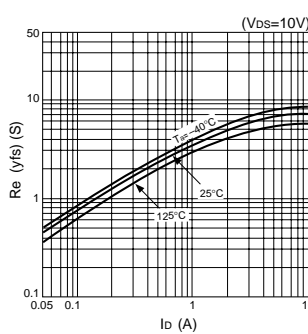

$R_{DS(ON)}$ - T_c Characteristics (Typical)

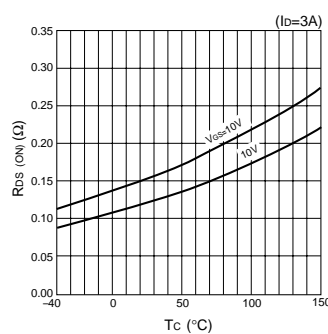

Capacitance- V_{DS} Characteristics (Typical)

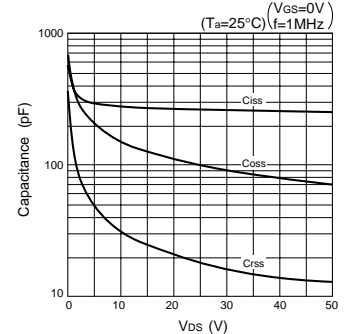

I_{DR} - V_{SD} Characteristics (Typical)

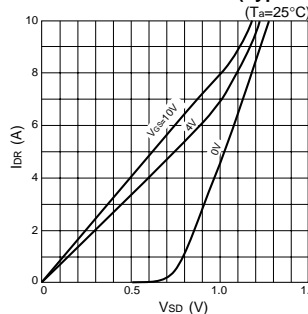

Safe Operating Area (SOA)

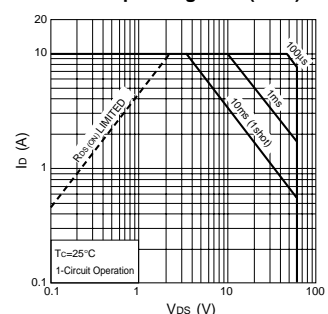

P_T - T_a Characteristics

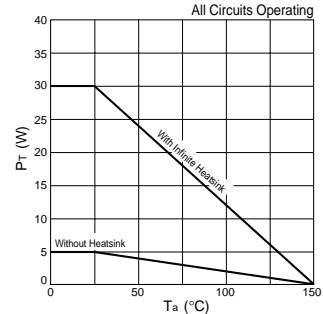

• SIP 8 (STA8Pin)

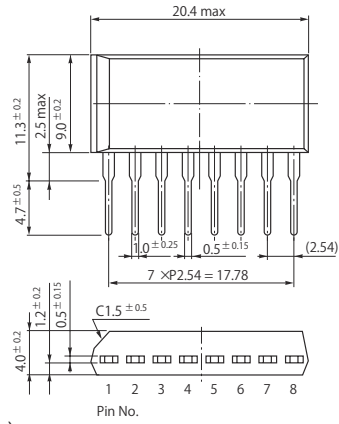

• SIP 10 (STA10Pin)

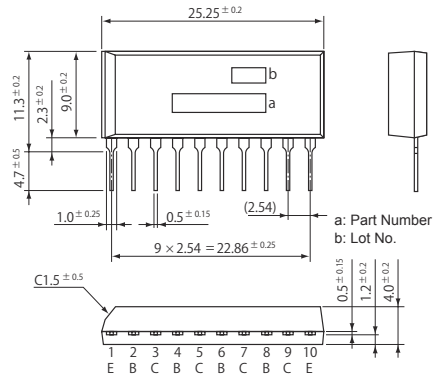

• SIP 12 (SMA12Pin)

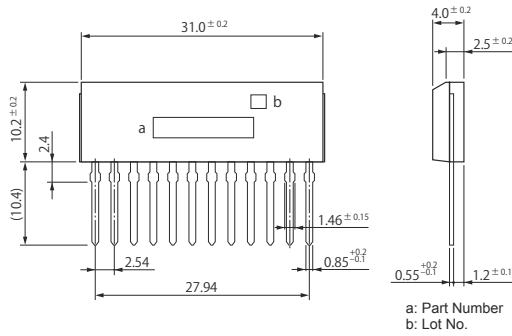

• SIP 15 (SMA15Pin)

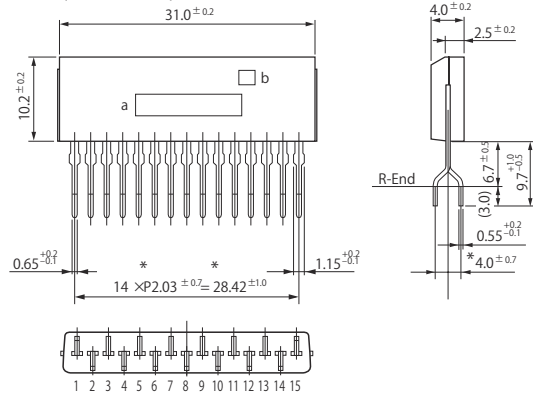

• SIP 12 with Fin (SLA12Pin)

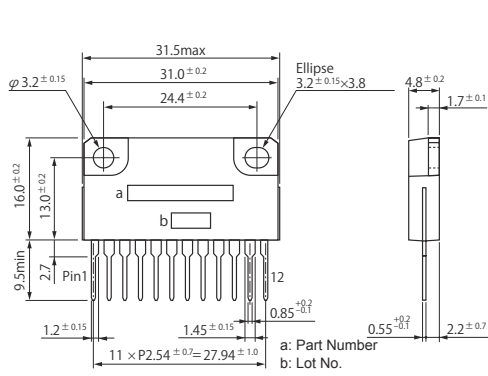

• SIP 15 with Fin (SLA15Pin)

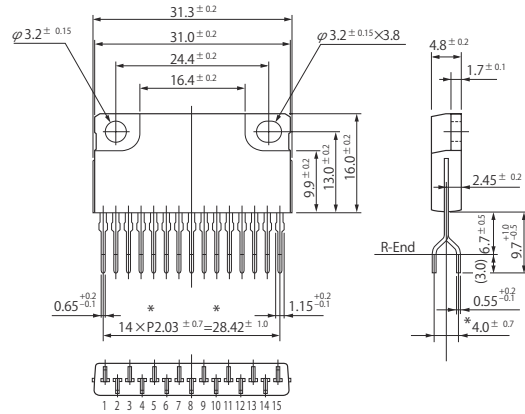

• SIP 21 with Fin (SLA21Pin)

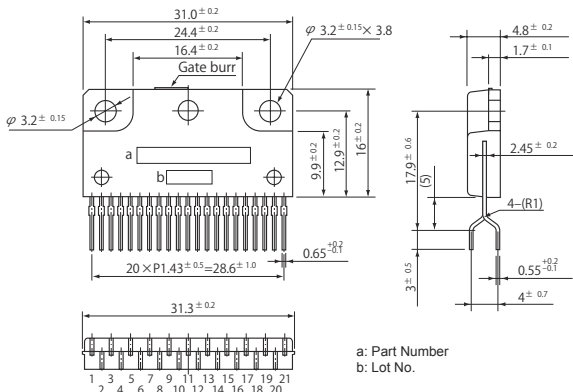

(Unit:mm)